



NMRA DCC Reference Manual
for
QSI Quantum[®] HO Equipped
Locomotives

Version 3.1
22 July 2006

Table of Contents

Table of Contents	2
Digital Command Control Explained	7
This Manual	7
1 Locomotive Operation under DCC	9
1.1 Getting Started	9
1.2 Direction Control	9
Locomotive Directional States under DCC Operation	9
1.3 Throttle Control and Speed Control	9
1.4 Sound of Power™	11
1.5 Function Keys	11
1.5.1 Common Feature Function Key Assignments	11
1.5.2 Function Key Operation Explained	11
1.6 Headlight and Reverse Light Operation (F0 or FL Key)	12
1.7 Horn and Bell Buttons (F2 Key and F1 Key)	13
1.8 Coupler Sound Effects (F3 Key)	14
1.9 Steam Blower Hiss and Cooling Fans (F4 Key)	14
1.10 Dynamic Brakes (F5 Key)	14
1.11 Doppler Operation (F6 in Forward and Reverse)	15
1.11.1 Horn Button Method	15
1.11.2 F6 Doppler Shift Operation Method	15
1.12 Squealing Brakes and Flanges (F7 in Forward or Reverse)	16
1.13 Air Brakes (F7)	16
1.14 Audio Mute (F8 Key)	16
1.15 Cruise Control (F9 in Forward or Reverse)	17
1.16 Status Report (F10)	17
1.17 Three Stages of Shut Down: Disconnect, Standby and Total Shut Down (F9 in Neutral)	17
Stage One: Disconnect	17
Stage Two: Standby	18
Stage Three: Total Shut Down	18
1.18 Start Up (F6 in Neutral)	19
Start Up from Disconnect	19
Start Up from Standby	19
Start Up from Total Shut Down	19
1.19 Automatic Features with “Take Control” Operation	19
1.20 Neutral Sounds	21
2 Programming	22
2.1 Configuration Variables Explained	22
Typical Factory Default Settings for Quantum Equipped Locomotives	22
2.2 Service Mode Programming	22
2.3 Operations Mode Programming	24

2.4	List of NMRA CV's Support by Quantum	25
3	CV Descriptions - Overview	28
3.3	CV 3 Acceleration Rate	31
3.4	CV 4 Deceleration Rate.....	32
3.5	CV 5 V-High	33
3.6	CV 7 Manufacturer's Version Number	36
3.7	CV 8 Manufacturer's ID.....	37
3.8	CV 11 Packet Time-Out Value.....	38
3.9	CV 17, 18 Extended Address.....	39
3.10	CV 19 Consist Address.....	42
3.11	CV 21 Consist Address Active for F1-F8	43
3.12	CV 22 Consist Address Active for FL and F9-F12.....	45
3.13	CV 23 Acceleration Adjustment	47
3.14	CV 24 Deceleration Adjustment.....	48
3.15	CV 25 Quantum Speed Table Selection.....	49
	Additional Information for the Curious Regarding QSI Speed Curves:.....	50
3.16	CV 29 Configuration Data	52
4	CV 33-46, Output Locations	55
4.1	Overview.....	55
	(Locomotive Start Up).....	55
4.2	CV 33 Output Location for FL(f)	57
4.3	CV 34 Output Location for FL(r)	59
4.4	CV 35 Output Location for F1	61
4.5	CV 36 Output Location for F2	63
4.6	CV 37 Output Location for F3	65
4.7	CV 38 Output Location for F4	67
4.8	CV 39 Output Location for F5.....	69
4.9	CV 40 Output Location for F6.....	71
4.10	CV 41 Output Location for F7	73
4.11	CV 42 Output Location for F8	75
4.12	CV 43 Output Location for F9	77
4.13	CV 44 Output Location for F10	79
4.14	CV 45 Output Location for F11	81
4.15	CV 46 Output Location for F12	83
5	CV 49-64, QSI Configuration Variables	85
5.1	Overview.....	85
5.1.1	Primary and Secondary Indices	85
5.1.1.1	Primary Index	85
5.1.1.2	Secondary Index.....	86
5.2	CV 49 QSI Primary Index.....	88
5.3	CV 50 QSI Secondary Index.....	89

5.4.1	CV 51.0 Operations Mode System Volume (PI = 0)	91
5.4.2	CV 51.1 Operations Mode Mute Volume (PI = 1)	92
5.4.3	CV 51.2 Special Sound Effects Enable (PI = 2)	93
5.5	CV 52.PI QSI Individual Sound Volume Control	94
5.5.1	Individual Sound Identifiers	95
5.6	CV 53.PI.SI Output Feature Assignment	96
5.6.1	QSI Feature Identification Numbers	97
5.6.2	Factory Default Settings	100
5.7	CV 55.PI QSI Feature Configuration	101
5.7	CV 55.110.5: Ditch Light Strobe Hold Time	101
5.8	CV 56.PI QSI Configuration	102
5.8.2	CV 56.4: QSI Throttle Mode (PI = 4)	102
5.8.3	CV 56.10: Speed Step to Scale MPH Scale Factor (PI = 10)	103
5.8.3	CV 56.12: Chuff Interval Scale Factor (PI = 12)	104
5.8.4	CV 56.128: Reset to Factory Default (PI = 128)	105
5.8.5	CV 56.129: Locomotive ID Access (PI = 129)	106
5.8.6	CV 56.254: About Quantum Decoder (PI = 254)	108
5.8.7	CV 56.255: Play Build Information (PI = 255)	108
5.9	CV 62 QSI Control	110
5.10	CV 64 CV Numeric Verbal Readout (Verbal CV Inquiry)	111
5.10.1	Standard NMRA CV's	111
5.10.2	QSI CV's	111
6.1	CV 66 Forward Trim	112
6.2	CV 67-94 User Defined Speed Table	113
6.3	CV 95 Reverse Trim	114
Appendix I		115
Sounds Available Under DCC Operation		115
Steam Sounds		115
1.1	Automatic Sounds	115
1.2	Controllable Sounds	115
Diesel Sounds		116
2.1	Automatic Sounds	116
2.2	Controllable Sounds	117
Electric Locomotive Sounds		119
3.1	Automatic Sounds	119
3.2	Controllable Sounds	119
Gas Turbine Sounds		121
4.1	Automatic Sounds	121
4.2	Controllable Sounds	121
Appendix II		123
Prototype Gas Turbine		123
DCC Operation for Quantum Gas Turbine		131
Introduction		131
Function Keys		131
Changing between Diesel and Gas Turbine Mode		132
Changing from Turbine to Diesel Mode Diesel Mode to Turbine Mode (F7)		133
Sound-of-Power™		134
Directional Lighting Operation (F0 or FL or Headlight)		134
Coupler and Coupler Crash Sounds (F3)		134
Horn and Bell Buttons (F2, F1)		134
Doppler Operation (F6)		135

Standard Throttle Control, Speed Control and Regulated Throttle Control	135
Cruise Control (F9).....	135
Squealing Brake and Flange Sounds (F7)	135
Dynamic Brakes (F5).....	136
Automatic Features with “Take Control” Operation.....	136
Three Stages of Shut Down: 1. Disconnect, 2. Standby, 3. Total Shut Down (F9)	136
Start Up (F6).....	137
Mute (F8).....	137
Function Key Operation in Neutral	137
DCC Programming for the Gas Turbine.....	139
Changing the System Volume Electronically in CV 51.0	139
Changing the Mute Volume Electronically in CV 51.1	139
Enable/Disable Doppler Shift from Whistle Signal Interrupt and Enable/Disable Turbine/Diesel Transition from Coded Horn (CV 51.2)	139
Changing Individual Sound Volumes (CV 52.X)	139
Standard Throttle Control, Speed Control and Regulated Throttle Control Options (CV 56.4)	140
Reset All CV's to Factory Default Values (CV 56.128.255)	140
Special Procedure for Short or Extended Address Programming (CV 56.129)	140
Disable/Enable Verbal Announcements (CV 62)	141
CV Inquiry with Verbal Feedback in Ops Mode (CV 64).....	141
Special Operation and Troubleshooting.....	142
Manual Volume Adjustment (Analog and DCC)	142
Using the Quantum Reset Jumper to Return Your Locomotive to Factory Default Values (Analog and DCC)	142
Program Track Operation (DCC).....	142
Reasons why Your Locomotive is Silent or will not Start (Analog and DCC)	142
Appendix III A	143
Recommended DCC Command Stations	143
Appendix III B	145
Programming a Long Address on Digitrax.....	145
Appendix III C	146
Programming a Long Address on North Coast Engineering (NCE)	146
Appendix IV	148
DCC Troubleshooting	148
Operations Mode.....	148
Service Mode Operation using the Program Track	149
Appendix IVa	150
Using the Quantum Hardware Reset and Volume Controls:.....	150
Appendix V	153
Different types of Feature Operation from Function Commands.....	153
Classification of DCC Signal Types	153
Classification of Feature Types.....	154
Quantum Features and Control Types	156
Appendix VI	159
Interaction of Function Keys, Function Groups, Function Inputs and Outputs and Feature Assignments	159
Appendix VII	162
Recommended Reading:	162
Appendix VIII	163
Application Notes:	163

Using DC Power Conversion for Block Signal Control.....	163
Appendix IX	165
Binary, Hexadecimal, Decimal Conversions	165
Appendix X	166
Rights and Obligations	166
Index	167

Digital Command Control Explained

Digital Command Control (DCC) is the standard adopted by the National Model Railroad Association (NMRA) in 1994¹ to allow compatible operation of all locomotives and Command Stations regardless of manufacturer.

DCC differs from Analog control in that DCC applies full voltage to the track at all times and controls the speed and functions of different locomotives by addressing each locomotive separately using assigned locomotive ID numbers. The control method is similar to modems that send digital signals to remote computers. Because each locomotive can be addressed separately, it is possible to control speed, lights, and sounds on different locomotives independently on the same powered track. DCC provides features and opportunities that are usually not currently available under conventional Analog Control², but does require the user to commit to a new and more complex operating system.

Quantum equipped locomotives have been designed to operate directly out of the box under NMRA standards for either conventional Analog DC operation or Digital Command Control. There are no switches in the locomotive that need to be set to select the type of control system. The Quantum System responds directly to the type of signal on the track.

This Manual

The Quantum DCC Reference Manual is divided into seven parts:

- The first covers basic operation under DCC and how to get started quickly with your Quantum equipped locomotive,
- The second covers programming Configuration Variables (CV's) that are used to customize your locomotive's performance,
- The third describes individual NMRA standard CV's supported by the Quantum System,
- The fourth deals with changing how features are assigned to different Function Keys,
- The fifth section describes CV's that are unique to the Quantum Sound and Control System,
- The sixth section describes additional NMRA CV's, and
- The appendices cover sound and features descriptions for each locomotive type, operation with different DCC Digital Command Stations, troubleshooting and Applications Notes.

Quantum is designed to operate all locomotive types using NMRA DCC control. The three most common locomotives are Steam, Diesel and Electric, although others, such as trolleys, powered commuter cars, subways, etc. can be operated under DCC as well.

Many operations of Quantum equipped locomotives, such as turning on and off the Bell, changing direction, blowing a Horn or a Whistle, are the same across all locomotive types. In addition, we have grouped some features that have a common function to operate in the same way using common terms across all model types. Special operations or behaviors for different types of Quantum equipped locomotives are described separately in the Operation Manual that comes with the locomotive. Any special features included in this Reference Manual will be described in sidebars or notes and in the Appendix section, *Sounds Available Under DCC Operation*.

1 The Electrical and Communication Standards were adopted by the NRMA in Portland OR in July, 1994. The basic Recommended Practices (RP's) were accepted in 1995 in Atlanta Georgia and the Service Mode RP's were established in 1996.

2 Some Quantum systems use an advanced Analog control system called QARC™ (Quantum Analog Remote Control) Technology that does provide many of the same features available in DCC. See the Quantum Analog Reference Manual for details.

Important Notes About Quantum DCC Operation

This reference manual completely describes all features currently available in DCC when operating a Quantum locomotive which has Q1 Version 6 and earlier firmware. If your locomotive has Version 7 or later firmware, use the Quantum DCC Reference Manual Version 4. To determine you software version read the contents of CV 7 (In Ops Mode, set CV 64 to 7 and hear verbal response).

As new Quantum locomotives are introduced, they may have features not found in earlier locomotives. Check the Operation Manual that came with your locomotive to determine which features apply to your locomotive. This document will evolve over time as new information is added to keep it as complete and current as possible.

Although reading the first section, “Locomotive Operation in DCC”, will allow you to begin operating your Quantum locomotive immediately, the purpose of this manual is not to teach you how to use DCC. We assume that you already have the working knowledge and experience to operate the different DCC features and program CV’s. If you are just getting started in DCC, there are several books listed in Appendix VII to instruct you in the operation of DCC layouts, turnouts, accessories, programming Configuration Variables (CV’s), etc.

1 Locomotive Operation under DCC

1.1 Getting Started

Although DCC operation can be very complex, it does not have to be. We have preprogrammed the common and more popular features for your locomotive to operate with most DCC command stations. The following brief operation description will get you up and running quickly with your Quantum equipped locomotive.

These simple steps will allow you to start operating your Quantum equipped locomotive immediately:

- Select locomotive number 3
- Set your controller to 128 (preferred) or 28 (acceptable) speed step range³
- Start your locomotive by turning up the throttle

1.2 Direction Control

The direction of your locomotive will change when you press the direction key. If the locomotive was moving at the time you pressed the direction button, the locomotive will slow at a speed determined by the deceleration setting in CV 4, come to a complete stop⁴ and then accelerate in the other direction as determined by the CV 3 acceleration setting. Settings for CV 3 and CV 4 are described in the section on DCC Configuration Variables.

When you reduce the throttle setting to zero, and the locomotive has come to a complete stop, it will automatically enter Neutral with special background sounds appropriate to its resting state. If the locomotive was moving Forward, the Headlight (or operating Mars Light) will dim when it stops and enters Neutral, which was common practice for prototype locomotives under Rule 17⁵. You will also hear a Short Air Let-off whenever the locomotive enters Neutral.

Locomotive Directional States under DCC Operation

Each Quantum locomotive has four distinct Directional States under DCC operation described below:

Forward (FWD): If the locomotive is set to the Forward Direction and is moving, it is in the “Forward” state . This is the same as any DCC operated locomotive.

Neutral from Forward (NFF): If the locomotive is set to the Forward Direction, and the throttle is turned down to zero speed step and the locomotive is stopped, it will be in a Neutral State called “Neutral from Forward”.

Reverse (REV): If the locomotive is set to the Reverse Direction and is moving, it is in the “Reverse” state. This is the same as any DCC operated locomotive.

Neutral from Reverse (NFR): If the locomotive is set to the Reverse Direction, and the throttle is turned down to zero speed step and the locomotive is stopped, it will be in a Neutral State called “Neutral from Reverse”.

1.3 Throttle Control and Speed Control

There are three ways your locomotive can respond to your throttle.

- **Standard Throttle Control (STC) :** Under Standard Throttle Control, the “power” to the locomotive is controlled directly by the throttle setting and the speed changes under varying loads. This is the type of throttle control that almost all locomotives use. Its disadvantage is that the locomotive may easily stall at low speeds from minor gear binding, turnouts, and curves.

³ If you set your controller to 14 speed-step operation without reconfiguring your Quantum system to the same speed steps in CV 29, your Directional Lighting will not operate correctly.

⁴ Earlier Quantum Systems would stop in Neutral for up to three seconds before changing direction. This period has been shortened to almost zero to make it easier and more efficient to do uncoupling over magnetic uncoupling tracks.

⁵ Rule 17, followed by prototype railroads, states: The headlight will be displayed to the front of every train by night, but must be dimmed or concealed when a train turns out to meet another and the entire train has stopped clear of main track, or is standing to meet trains at the end of double track or at junctions.

- **Speed Control (SC):** Speed Control uses internal motor control electronics to maintain the same speed regardless of varying load conditions. Under speed control, the throttle setting (using 128 speed steps) selects the locomotives speed in 1 smph (scale miles per hour) increments. For instance, if your throttle is set at 35, the model locomotive will go 35 smph on level track or up hill or down hill. If you use 14 or 28 speed steps, you will need to multiple your settings by 9 and 4.5 respectively to compute your scale speed. The disadvantage is that in Consists, the power is not shared evenly among all locomotives, if there is even slight mismatch in speed calibration. For further explanation, see CV 56.4.
- **Regulated Throttle Control (RTC) :** RTC combines the benefits of Standard Throttle Control and Speed Control and is the preferred method when multiple heading Quantum locomotives together because it equalizes power between locomotives. RTC, like Speed Control, will also allow you to run your locomotive very slowly without concern that it will abruptly stop from minor impediments such as misaligned track joints, tight curves, rough switches, etc. RTC operates your locomotive as though it has inertia; your locomotive will resist changes in speed once it is moving and will resist starting up quickly if at rest. For instance, if your locomotive under RTC encounters a grade, it will eventually slow down. Providing more throttle will slowly accelerate it back to speed.

Note: The default is RTC". If you prefer, change to Regulated Throttle Control or Standard Throttle Control in CV 56.4.

Important Legal Notice

Regulated Throttle Control, Speed Control and Cruise Control features may not be included in your locomotive model under DCC operation. These two functions have been eliminated by some model railroad importers of Quantum equipped locomotives because of threats of litigation by Mike's Train House. QSI believes the claim by Mikes Train House is unfounded because these control features were developed by QSI and others and were in use long before Mike's Train House claims to have invented them. QSI does not believe that Quantum Sound System infringes any MTH patent.

Check your individual Operation Manual that came with your locomotive to determine if these features are included in your particular model.

1.4 Sound of Power™

Quantum locomotives will produce labored sounds under acceleration and lighter non-labored sounds under deceleration⁶ and but only if CV 3 and CV 4 and/or CV 23 and CV 24 are set to non-zero values. The level of labored sounds is proportional to the level of CV 3 and CV 4 and/or CV 23 and CV 24, and how much the throttle is increased or decreased.

1.5 Function Keys

The following table lists features that have been pre-assigned to your DCC Function Keys for common operation across the different types of locomotives currently supported by Quantum. Operation of these keys can be different in the Neutral State (locomotive stopped) and the Motive State (locomotive moving in Forward or Reverse). Check the Operation Manual that comes with each locomotive to see which of these common features are offered or what additional custom features have been included. Each of the common features is described in detail below the table.

Note: Quantum supports the 0-12 Function Key standard as now accepted by the NMRA; the old 0-8 standard is not supported in new Quantum equipped locomotives⁷.

1.5.1 Common Feature Function Key Assignments

Default F-Key	FWD/REV	NFF/NFR
FL(f) ⁸	Headlight, Reverse Light, and Hazard Light Directional Lighting	Headlight, Reverse Light, and Hazard Light Directional Lighting
FL(r)	Headlight, Reverse Light, and Hazard Light Directional Lighting	Headlight, Reverse Light, and Hazard Light Directional Lighting
F1	Bell	Bell
F2	Whistle/Horn	Whistle/Horn
F3	Coupler Crash-Coupler Fire	Coupler Arm (Enable) or Coupler Fire
F4	Steam Blower Hiss/ Diesel Fans and Louvers/ Electric Cooling Fans	Steam Blower Hiss/ Diesel Fans and Louvers/ Electric Cooling Fans
F5	Dynamic Brakes	Dynamic Brakes
F6	Doppler Shift	Locomotive Start Up
F7	Brake Squeal-Flanges and Air Brakes	Long Air Let-off or Gas Turbine Start Up/Shut Down toggle.
F8	Audio Mute	Audio Mute
F9	Short Air Let-off or Cruise Control ⁹	Shut Down ¹⁰ : Disconnect-Standby set-Total Shut Down
F10	Status Report (SMPH)	Status Report (ID's, etc.)
F11	Number Board Lights	Number Board Lights
F12	Automatic Cab Lights	Automatic Cab Lights

- The FL Key is sometimes labeled F0, Headlights, Lights or Directional Lighting on different DCC controllers.

1.5.2 Function Key Operation Explained

Most DCC hand held controllers have 9 to 13 Function Keys for operating various features. Before Sound Decoders became available, there was limited use for a large number of Function Keys. Usually, functions were applied to different lights and perhaps to some mechanical appliances such as smoke units, etc. Sound decoders can require

⁶ Steam locomotives produce louder chuffs under acceleration and lighter low volume chuffs under deceleration. Diesel locomotives produce louder Diesel Motor sounds under acceleration and lower volume sounds under deceleration.

⁷ The only Quantum equipped locomotive using the F0-F8 specification is the 2002 J1e Hudson by BLI, version ho300a02.

⁸ FL(f) and FL(r) control the on/off of Headlight, Reverse Light, and Hazard Directional Lighting regardless of which direction the train is moving.

⁹ Cruise Control was only available on locomotives equipped with Speed Control.

¹⁰ There are three stages to Shut Down. To operate Shut down, you will need to double click the F9 key for each stage.

many more functions to operate the different sound features and also require a different use of the standard function key commands. In order to understand how we define the operation of our various sound features, it is worthwhile to understand how function commands operate.

Each function has two values, which were intended to operate features as follows: a “1” turns the feature on while a “0” turns the feature off. Many decoders show readouts of each function value, which allows the operator to know the status of the function without looking at or listening to the locomotive. For instance, if he sees that FL is “on” at the controller, he knows his directional lights are “on” in the locomotive.

Function Groups: Instead of the Function Commands being sent out as individual commands, they are sent out in groups to the selected locomotive. **Function Group One** sends out the commands for Functions F0 (or FL) and F1 – F4. **Function Group Two** sends out the commands for either Functions F5 – F8 or F9 – F12.

Some decoders do not send out function groups until there is a change to one of the functions within that group. For instance, the controller may have Functions 1, 3 and 4 turned on (set to 1's) while Functions 0 and 2 are off (set to 0's). When the user changes Function 2 to on, then Function Group 1 is transmitted to the locomotive with the entire set of bits for all functions FL, and F1- F4.

This normally does not cause a problem if the locomotive had previously received all of the function settings at the last transmission. However, if the locomotive's function states do not match the controller, the user can expect other functions to respond besides the one that is being changed.

For instance, if the FL command is registered as on (1) in the locomotive while it is shown as off (0) at the DCC controller, then sending a command to turn on the bell, F1, would have the additional effect of turning off the lights.

Understanding how function groups operate can explain a mystery about Quantum Directional Lighting.

Why does QSI choose to have the Directional Lights off by default?

If we assume that the user prefers to have his Directional Lights on during operation, why do we have Quantum Directional Lighting System off by default when a locomotive is selected? To understand this, consider the case where we have the lights on by default. If the lights were on in the controller and any other function key were pressed in Function Group One, then the lights would stay on; this is certainly good. However, if the lights were off in the controller, and the user pressed some other function key in Function Group One, then the lights would turn off. He would then need to turn the lights back on. This can be distracting, especially with Steam Locomotives that have a very distinctive turn on and turn off Dynamo sound effect. The observer would see and hear the lights come on by default, then turn off when he pressed some other function key like the Whistle, and then turn on again when he presses the FL Key– very non-prototypical.

However, if the locomotive lights were off by default and the controller had the lights registered as on, then the lights would come on if any other function key were pressed – this is good. On the other hand, if the controller has the lights registered as off, then the lights stay off when another function command is sent in Function Group One – this is also good. The user could then send his Light function command to turn the lights on.

To complicate the above problem, some controllers do not reset their function settings when a new locomotive is selected. Pressing any function key will send out a set of function commands that were selected for the previous locomotive, that may not be what the operator wants for the newly selected locomotive.

1.6 Headlight and Reverse Light Operation (F0 or FL Key)

The F0 key turns the Directional Lighting System on or off. If F0 is “1”, the Directional Lighting System will be on. If the F0 output is “0” the Directional Lighting System will be off. Once the Directional lighting system is turned on, Forward and Reverse lights will react to direction changes.

Some locomotives have “dim” headlight capability. If the locomotive enters Reverse or stops in Neutral From Reverse or stops in Neutral From Forward, the headlight will go to a dim setting. The Headlight will be at its bright setting only in Forward.

The table below is a summary of light operation in the different directional states for locomotives that have “dim” headlight capability.

	Forward	Neutral from Forward	Reverse	Neutral from Reverse
Headlight	On	Dim	Dim	Dim
Reverse Light	Off	Off	On	Off

The table below is a summary of light operation in the different directional states for locomotives that do not have “dim” headlight capability.

	Forward	Neutral from Forward	Reverse	Neutral from Reverse
Headlight	On	Off	Off	Off
Reverse Light	Off	Off	On	Off

Some locomotives are equipped with a special strobing hazard light called a Mars Light, or with a pair of Ditch Lights which strobe when the Horn blows, mounted on the front of the locomotive. The table below is a summary of Mars Light and Ditch Lights operation in the different directional states.

	Forward	Neutral from Forward	Reverse	Neutral from Reverse
Mars Light*	Strobing	Dim non-pulsing	Dim	Dim non-Pulsing
Ditch Lights	On; Strobes when Horn blows	Off	Off	Off

*If your locomotive has a Mars Light, the Headlight may not be dimmable. In those directional states where the Headlight would normally be dim, the Headlight is off.

Steam locomotives use a steam-powered generator, called a Dynamo, to supply electricity to the lights. When the lighting system is turned on, the steam generator revs up to full power over a couple of seconds as the brightness of the headlight comes on slowly. Check your Operation manual to see if your model has this feature.

Note: If your F0 or FL key does not predictably affect the headlight or Reverse Light, see the troubleshooting section in the appendix.

Note: Some base stations do not send the light toggle command when the locomotive is first turned on. To turn the directional lights on, press the F0 key once or twice after the locomotive is selected. Read the trouble shooting section for further information.

Note: The default for directional lighting is off. See *Why does QSI choose to have the Directional Lights off by default?* on page 11.

1.7 Horn and Bell Buttons (F2 Key and F1 Key)

For DCC controllers that have a bell button and a horn button, there are Function Keys that perform the same operations. The horn button is usually assigned to F2. If you press the F2 Key or the horn button, the Whistle or Horn will blow. The bell buttons might be assigned to F3 or F1 on your DCC controller.

- Pressing the F2 Key and releasing it will cause the Whistle or Horn to come on and stay on, until you press F2 again.
- Pressing the F1 Key and releasing it will cause the Bell to come on and stay on, until you press F2 again.

Note: If your DCC controller has assigned the Bell to F3, you can reassign Quantum Function 3 to the bell output (see CV 37). Remember to reassign the F1 Function to some other output besides 3 (see CV 35). Definitions and assignments of functions are described later in this manual.

Note: Pressing the F2 key and releasing it will cause the Whistle or Horn to come on and stay on, and pressing it again will turn it off. On the other hand, if you have a horn button, it will blow the Whistle/Horn only as long as you are holding the horn button down. When you release the horn button, the Whistle/Horn will stop. There is no difference in operation between the bell button and its corresponding function key.

1.8 Coupler Sound Effects (F3 Key)

There are two ways to use the F3 key.

- As your locomotive is about to couple up to a string of cars, press the F3 key to produce the crashing sound of a locomotive coupling. Use the F3 key again as the locomotive moves to produce the same sound as the slack is taken up in the cars.
- Or use the F3 key in Neutral to produce uncoupling sounds as you disconnect cars over an uncoupler magnet. Press the F3 key once to produce the sound of the lift bar and coupling pin being raised. This operation also arms the uncoupling sound effect. Press the F3 key again while moving or in Neutral to produce the sound of the coupler knuckle opening (fire the coupler) and the brake air-lines parting.

If you have armed the Coupler in Neutral and are now in Forward or Reverse, pressing the F3 Key will produce the coupler opening sound. Thereafter, as you continue in Forward or Reverse, the F3 Key will produce Coupler Crash Sounds.

1.9 Steam Blower Hiss and Cooling Fans (F4 Key)

Steam Blowers are used to increase the draft in the firebox by venting steam through the smoke stack. This creates a steam hiss sound heard quite often around idling Steam locomotives. When you press the F4 Key in Forward/Reverse or Neutral, Blower Hiss will turn on or off. If it is turning on, you will hear the hiss sound increase in increments for each turn of the value as the fireman adjusts the blower. If it is turning off, you will hear the hiss sound decrease in increments.

For Diesels and Electrics, F4 turns on or off the Vents and Cooling Fans. If the Cooling Fans are turned off, you will hear the fans gradually stop followed by the Vents and Louvers closing. If the Cooling Fans are being turned on, you will first hear the Vents and Louvers opening followed by the Fans coming on.

1.10 Dynamic Brakes (F5 Key)

Diesel Locomotives: The prototype Dynamic Brakes, found on most diesels, cause the train to slow down by using the traction motors in generator mode. This helps dissipate the energy of a moving train by applying electrical power from the traction motors to a large air-cooled resistor load in the locomotive. These resistor grids can get quite hot and require cooling by fans located on the roofs of the locomotives.

- Pressing the F5 key in Forward/Reverse will set the Diesel Motor sound to idle at the lowest Sound of Power setting and turn on the powerful Dynamic Brake Cooling Fans.
- Pressing the F5 key in Neutral will have no Dynamic Brake effect unless the locomotive is in Disconnect¹¹.

Steam Locomotives: Prototype Steam locomotives do not have Dynamic Brake sounds. However, the Dynamic Brake function has been included to make Steam locomotives consistent with other Quantum equipped locomotives.

- Pressing the F5 key will set the Steam Exhaust Sound-of-Power to the lowest setting allowing the Steam locomotive to behave consistently¹² with other locomotives that do have Dynamic Brake sounds in multiple unit Consists.

Electric Locomotives: Early Electric locomotives did not have Dynamic Brakes. However, the Dynamic Brake function has been included to make Electric locomotives consistent with other Quantum equipped locomotives.

¹¹ Under Disconnect, the Diesel Motor can be revved up and down in Neutral with Dynamic Brakes on (see page 17 - Disconnect).

¹² It would be inconsistent for the Steam Locomotives to be working at full Sound-of-Power while brakes are being applied in other locomotives within the same consist.

- Pressing the F5 key will set the Electric Traction Motor Sound-of-Power to the lowest setting allowing these early Electric Locos to behave consistently¹³ with other locomotives that do have Dynamic Brake sounds in multiple unit Consists.

If an Electric Locomotive has Dynamic Brakes with resistor grids and cooling fans, the locomotive will behave in a similar manner to Diesels.

Note: The Dynamic Brake function automatically turns off when entering or leaving Neutral, or the speed of the locomotive drops below 8 smph, or if the throttle is turned up. The Dynamic Brakes cannot be turned on in Forward or Reverse unless the locomotive is traveling over 9 smph.

1.11 Doppler Operation (F6 in Forward and Reverse)

There are two ways to control the Doppler effect. If your controller has a horn button in addition to the F2 key, use the horn button in the same way as it is used under conventional Analog control to trigger the Doppler effect.

1.11.1 Horn Button Method

- While the locomotive is moving towards the observer, press the horn button to turn on the Whistle/Horn.
- Wait at least one second while the Whistle/Horn is blowing
- Release and re-press the horn button quickly so the Whistle/Horn does not shut off. Instead you will hear the Whistle/Horn and locomotive sounds increase in volume and shift in pitch as the locomotive passes by and then reduce in volume.
- Release the horn button at any time or continue blowing long and short blasts. When you release the button and do not re-press the horn button within five to seven seconds, the sounds will gradually return to normal.

Note: We have experienced that some base stations produce an intermittent and independent horn signal interruption that causes an unexpected Doppler shift. If this happens frequently, you may want to disable the automatic Doppler shift in CV 51.2.

Note: If the bell was on during the Doppler Shift, it will automatically turn off prior to the sounds returning to normal.

1.11.2 F6 Doppler Shift Operation Method

- Start the whistle by pressing and releasing the F2 key.
- Press F6 Doppler shift key. All sounds, including the whistle will go through Doppler shift as the locomotive passes by.
- Press the F2 button to shut off the horn or continue blowing long and short blasts by pressing and re-pressing the F2 button. If you shut off the horn for more than five seconds, the sounds will gradually return to normal.

Note: You might try using the F6 key to affect the chuffing sounds (sans Horn or Bell) to create interesting environmental effects.

Note: With some Command Stations, using the horn button to activate the Whistle/Horn, and then while this button is held down, activating the F6 Doppler Key will cause the whistle to shut off instead of causing a Doppler shift effect.

Note: If Doppler shift is initiated without the horn blowing, the sounds will soon return to normal after the Doppler shift is finished. If the Bell is ringing, it will shut off automatically before the sounds return to normal.

Note: Doppler is speed dependent. The greater the speed, the greater the amount of pitch change as the locomotive passes by. There is no Doppler shift at speeds less than 15 scale miles per hour (smph); instead you will hear a short air let-off when F6 is pressed.

¹³ It would be inconsistent for the Electric Locomotive to be working at full Sound-of-Power while brakes are being applied in other locomotives within the same consist.

1.12 Squealing Brakes and Flanges (F7 in Forward or Reverse)

Squealing brakes will occur automatically when the speed is reduced to 20 smph just before stopping. This effect only occurs if the locomotive has previously exceeded 40 smph prior to stopping. This prevents the automatic brakes from occurring too often for short switching maneuvers at low speeds.

However, squealing brakes can be manually activated anytime by pressing the F7 key when the locomotive is moving at any speed.

- Press the F7 Key to start the squealing brakes sounds.

Although squealing brakes sounds will end automatically, you can press the F7 Key at any time while the brake squeal is occurring to re-trigger the squealing sounds; this allows you to continue the brake sound effects without any dead period for an indefinite period. With a little practice, you can extend brakes sounds to simulate long stops or the sound of locomotive flanges and car flanges as your train moves through long curves.

Note: If you slow the locomotive too quickly, the brake sounds will terminate abruptly when the locomotive stops and enters Neutral.

Note: If you lower your throttle to speed step 0 on a moving locomotive, the F7 key will apply Air Brakes as long as the locomotive continues moving and will affect how rapidly it comes to a stop (see below).

1.13 Air Brakes (F7)

If you have selected any non-zero deceleration inertia or momentum value in CV 4 and/or CV 24, the F7 key can be used to apply Air Brakes to stop the locomotive more quickly than it would normally stop from the inertia settings¹⁴. To use Air Brakes:

- Turn the throttle down to speed step 0 on a moving locomotive; this enables the F7 key to act as a brake.
- Press the F7 key. Hear a brief brake squeal sound and air being released from the brake lines continually. The longer the air is released the greater the braking action.
- Press the F7 key again to stop the air release. The train will continue to slow at the last braking value.
- If you want to apply more braking, press the F7 key again to release more air. When you reach the desired amount of braking, press F7 again to stop the air release.

Note: If you continue to release air, all the pressure will eventually be released and brakes are on full; you will hear no further air release sounds.

- Turn up the throttle to any value above 0 to release the brakes; this returns the locomotives deceleration to a value determined by the sum of CV 4 and CV 24.
- If the locomotive is in Neutral when the F7 key is pressed, a Long Air Let-off sound simulates setting the brakes. However, no braking effect is activated¹⁵.

If the throttle is set to any speed step except 0, Air Brakes are not enabled; instead the F7 key will now manually activate Squealing Brake/Flange sounds but will not affect the locomotive's deceleration.

1.14 Audio Mute (F8 Key)

Quantum provides a way to quickly shut off or reduce in volume all locomotive sounds if you wish to talk on a phone or have a conversation with another person.

- Set F8 Function to "1" in Forward, Reverse or Neutral. All sounds, including the Whistle, Bells, Motors and Chuff will gradually go off.

¹⁴ CV 4 and CV 24 determine the deceleration rate. Applying the brakes increases this deceleration rate.

¹⁵ If the brakes are set in Neutral, turning up the throttle automatically releases the brakes.

- Set F8 Function to “0” in Forward, Reverse or Neutral. All sounds, including the Whistle, Bells, Motors and Chuff will gradually go on.

Note: CV 51.1 will allow you to set the Mute volume so the sound does not go completely off when Mute is activated. This will still allow you to reduce the volume to make a phone call or talk to a friend but does not have the effect of turning the sounds completely off. In addition, you can use this feature to increase sounds for locomotives that approach the front or foreground of your layout and reduce sounds for locomotives that are in the distance.

1.15 Cruise Control (F9 in Forward or Reverse)

Quantum Cruise Control¹⁶ behaves in much the same way as cruise control on a modern automobile.

- Press F9 and hear two short toots when Cruise Control is toggled on.
- Press F9 and hear one short toot when Cruise Control is toggled off.

When Cruise Control is on, the locomotive will continue at its present speed regardless of grades, changes in load, or tight curves. Turning the throttle up or down will not affect locomotive speed, but will cause Sound-of-Power chuffing or Diesel Motor labor sounds to change in direct proportion to the throttle’s movement from the initial setting (where Cruise Control was turned on). You can increase the laboring motor sounds in Cruise Control as a train climbs a grade or decrease the Sound-of-Power effects as the train moves down the grade.

Return the throttle to its initial setting to avoid acceleration or deceleration when Cruise Control is toggled off.

Cruise Control is only available under Regulated Throttle Control or Speed Control.

Note: Cruise Control is automatically turned off when the speed step is reduced to zero or track power is turned off.

1.16 Status Report (F10)

Quantum provides verbal information about the locomotive’s current operating state when the locomotive is in Neutral or the locomotive’s current speed in scale miles per hour when the locomotive is moving.

- Press the F10 key in Neutral; the locomotive will verbally report first its currently enabled long or short loco ID followed by its consist ID if it has one, followed by its Shut Down state (Disconnect, Standby or Shut Down).
- Press the F10 key in Forward or Reverse; the locomotive will verbally report the locomotive’s speed in scale miles per hour (SMPH).

Note: When Neutral Status Report or Verbal Speedometer Readout is activated, the locomotive’s sounds will reduce to one half their current volume settings during the verbal report and then return to normal volume when the report has ended.

Note: In a Consist, all locomotives will simultaneously report their status when the F10 key is pressed unless the function is disabled in CV 22.

1.17 Three Stages of Shut Down: Disconnect, Standby and Total Shut Down (F9 in Neutral)

Locomotive Shut Down has three distinct stages, all controlled by the operator. Each stage is entered by double-clicking or double-pressing the F9 Key¹⁷.

Stage One: Disconnect

- Double-press the F9 key in Neutral to enter Disconnect. Hear a long air let-off.

¹⁶ Cruise Control and Speed Control was only available in Lionel HO and a limited number of early BLI HO locomotives.

¹⁷ Double-clicking ensures that Shut Down stages are not entered or exited accidentally. Doubling-pressing is defined as two F9 presses within two seconds. Note that the F9 key may have to be pressed three times the first time you use it due to the command station and locomotive having different initial states for F9.

- To leave Disconnect, either double-press the F6 Start Up key described in the Start Up section or double-press the F9 key again to reach the next stage of Shut Down, Standby.

If you double press the F9 Key in Neutral, the motor drive will be disconnected from the Quantum Sound system. You will hear a Long Air Let-off after entering Disconnect, which represents the pneumatic reverse lever on a Steam locomotive being placed in the Neutral position or the Diesel transition level being placed in the off or disconnect position. Once in Disconnect, the throttle can be moved up and down without the locomotive moving. All function keys are active in Disconnect.

Note: If the throttle on a Diesel is increased or decreased, the motor sounds will rev up and down but the locomotive will not move. If the Dynamic Brakes are activated, the motors sounds will be labored under Sound of Power control as the throttle is increased and decreased. Prototype Diesel Motor/Generator power output is often tested under Dynamic Brake load in disconnect.

Note: If the throttle on a Steam locomotive is increased or decreased, the hissing sound of venting steam will get louder and softer but the locomotive will not move. Prototype Steam locomotives would sometimes vent steam in Neutral to clear rust debris from the super-heaters that can affect the throttle.

Note: For Electric locomotives, there is no action or sound associated with moving the throttle up and down and no affect from having the Dynamic Brakes activated.

Stage Two: Standby

- Double press the F9 key while in Disconnect to enter Standby.
- To leave Standby, either double-press the F6 Start Up key described in the Start Up section or double-press the F9 key again to reach the final stage of Shut Down, Total Shut Down.

If you double-press the F9 key while in Disconnect, the locomotive advances to Standby. You will hear a Long Air Let-off followed by Directional Lighting and optional Mars Light turning off. The motor will remain disconnected, while the Air Pumps, automatic Steam Blower/Cooling Fan operation, Number Board Lights and Cab Lights will continue to operate. In Standby, the locomotive will not respond to throttle or most function keys. The three exceptions are the F6 Start Up Function Key (described below), the F8 Mute Key (described above) and the F10 Status Key (described above).

Note: Standby in Diesels, called Low Idle, has more utility than Standby in Steam and Electric locomotives. It allows a Diesel to be left on a siding inactive with only the motor running at its special "Low Idle" sounds. For Steam and Electrics, the locomotive will appear to be completely inactive except perhaps for Cab and Number Board lights and occasional Air Pump or Blowers and Fan sounds.

Stage Three: Total Shut Down

- Double-press the F9 in Standby to enter Total Shut Down.
- To leave Total Shut Down, double-press the F6 key.

If you double press the F9 key while in Standby, the locomotive advances to Total Shut Down. The Air Pumps will turn off plus a few other locomotive-specific shut down sounds. Under Total Shut Down, Function Keys will have no affect. The two exceptions are the F6 Start Up Function Key (described below) and the F10 Status Key (described above).

Total Shut Down procedures are different for different locomotives.

Steam Locomotive: The Air Pumps will turn off, followed by the sounds of Pop Off Operating for about ten seconds, the Cab Lights shutting off, and finally the Blower Hiss will trail off and finally shut off completely.

Diesel Locomotive: Low Idle Diesel Motors will return to normal idle sounds, the Air Pumps will turn off, as will the Number Board Lights, followed by the sounds of the Cooling Fans shutting off, the Louvers closing, the Diesel Motor(s) shutting down, Cab Lights shutting off, and finally the engineer's door opening and shutting.

Electric Locomotive: The Air Pumps will turn off, Cab Lights will turn off, followed by the sounds of the Louvers being closed and the engineer's door being opened and shut.

Note: If power is turned off at any stage of Shut Down (Disconnect, Standby or Total Shut Down) or during a Shut Down procedure, the locomotive will remember its last Shut Down command, and will power up in that Shut Down

stage¹⁸. If Start Up is initiated during any of the above Shut Down procedures, Shut Down is aborted and the locomotive returns to normal operation.

1.18 Start Up (F6 in Neutral)

If your locomotive is in any of the Shut Down stages, you can return your locomotive to normal operation by double-pressing¹⁹ the F6 Key. Start Up will be different for each stage of Shut Down, but all will start up with a Long Air Let-off and will enter normal operation²⁰.

Start Up from Disconnect

- Double press the F6 key in Disconnect, the locomotive will produce a Long Air Let-off and enter normal operation.

Start Up from Standby

- Double press the F6 key in Standby, the locomotive will produce a Long Air Let-off, the Directional Lighting will turn on and then the locomotive will enter normal operation.

Start Up from Total Shut Down

- Double press the F6 key in Total Shut Down; the locomotive will produce a Long Air Let-off, and begin a full start up procedure.

Note: During the Start Up procedure, Quantum will not respond to any of function keys.

Start Up procedures from Total Shut Down are different for different locomotives.

Steam Locomotives: The Quantum System will produce a Long Air Let-off, the Dynamo will rev up and the Directional Lighting will turn on (if previously turned “on” and a Normal locomotive or Lead Helper), then Cab Lights will turn on (if available), followed by the Air Pumps and the Steam Blower turning on and finally the locomotive entering normal operation.

Diesel Locomotives: The Quantum System will produce a Long Air Let-off, followed by the sound of the engineer’s door opening and closing, Cab Lights turning on (if available and Normal or Lead Helper), Number Boards coming on (if available and a Normal locomotive or Lead-Helper), Directional Lighting turning on (if previously on), followed by the Vents opening and Fans starting up, the Diesel Motor or Motors starting up one at a time, the Air Pumps turning up, and finally the locomotive entering normal operation.

Electric Locomotives: The Quantum System will produce a Long Air Let-off, followed by the sound of the engineer’s door opening and closing, Cab Lights coming (if available and Normal or Lead Helper), Number Boards and colored Marker Lights turning on (if available and a Normal locomotive or Lead-Helper), Directional Lighting turning on (if previously on), followed by the Vents opening and Fans starting up, the Air Pumps turning on, and finally the locomotive entering normal operation.

Note: If the throttle is turned up from zero during any of the above Start Up procedures, the Start Up procedure will abort and the locomotive will enter normal operation.

Note: Whenever a Start Up command is sent, regardless of whether the locomotive is in a Shut Down stage or operating normally, the Quantum System will automatically restore all Automatic Operations disabling all Take Control operations.

1.19 Automatic Features with “Take Control” Operation

Some sound features, like Steam Blower Hiss, operate automatically by turning on in a few seconds after entering Neutral and off again in Forward or Reverse where they are no longer required. Automatic features may also have Function Keys for manual operation. Since there are two ways to control these special features, it is a potential conflict about which method actually wins, the automatic operation or the operator. We deal with this problem by using

¹⁸ Total Shut Down allows you to take a locomotive “off-line” (turn off sounds, lights, ignore throttle and function commands (except turn on)) independent of the operating session; that is, the locomotive will still be “off line” when power is reapplied for the next operating session.

¹⁹ Double-pressing ensures that Start Up is not entered or exited accidentally. Doubling-pressing is defined as two F6 presses within two seconds. Note that the F6 Key may have to be pressed three times the first time you use it due to the command station and locomotive having different initial states for F6.

²⁰ Locomotive enters Neutral with Long Air Let-off if speed step is zero. If speed step is non-zero, locomotive will enter either forward or reverse.

a concept called “take control”. Once the operator “Takes Control”, the feature will no longer have automatic operation and instead will be controlled by its associated function key commands. Automatic and Take Control operations are described in the table below for our current Steam, Diesel and Electric Locomotives.

Steam “Take Control” Operation

	Automatic Operation			Take Control	
	Forward	Reverse	Neutral	Function Key	Operation
Steam Blower	Off after 10 sec	Off after 10 sec	On after 10 sec	F4	Turns Steam Blower On/Off

- Take Control of the Automatic Steam Blower with the F4 key to stop automatic operation and control whether the Steam Blower is On or Off.

Note: When you Take Control, you will change the state of the Steam Blower in addition to taking control of the feature. For instance, if the automatic Steam Blower is on, pressing the F4 key to off (0) will toggle the Steam Blower to off and it will stay off.

Diesel “Take Control” Operation

	Automatic Operation			Take Control	
	Forward	Reverse	Neutral	Function Key	Operation
Vents & Cooling Fans	Non-operating	Non-operating	On and off at random times	F4	Turns Vents/Fans operation On/Off.

- Take Control of Automatic Fans with the F4 key to stop automatic operation and control whether the Cooling Fans are on or off.

Note: When you Take Control, you will change the state of the Cooling Fans in addition to taking control of the feature. For instance, if the automatic Fans are on, pressing the F4 key to off (0) will toggle the Fans to off and they will stay off.

Electric Locomotive “Take Control” Operation

	Automatic Operation		Take Control	
	Forward/Reverse	Neutral	Function Key	Operation
Cab Lights	Lights off after 15 sec	Lights on after 10 sec	F12	Turns Cab Lights On/Off
Cooling Fans	On after 20 sec	Off after 10 sec	F4	Turns Cooling Fans On/Off

- Take control of the Cab Lights with the F12 key to stop automatic Cab Lights operation.
- Take Control of Automatic Fans with the F4 key to stop automatic operation and control whether the Cooling Fans are on or off.

Note: When you Take Control, you will change the state of the Cab Lights and/or Cooling Fans in addition to taking control of the feature. For instance, if the automatic Cab Light is on, pressing the F12 key to off (0) will toggle the Cab Lights to off and they will stay off while you operate the locomotive, until you toggle the Take Control feature to on using the F12 Key.

Note: Automatic operation will be restored if the power is shut down and reapplied or if the F6 Start Up key is double-pressed in Neutral (see the description of Start Up above).

1.20 Neutral Sounds

Some of the same function keys used in Forward and Reverse will have different effects in either of the two Neutral States.

- The F7 Key produces Brake Squeal or Air Brakes for a moving Steam Locomotive but activates the Boiler Water Injector if the locomotive is in Neutral.
- F6 results in Doppler shift for a moving locomotive but activates Start Up when in Neutral.
- F9 toggles Cruise Control²¹ when the locomotive is moving but activates Shut Down in Neutral.

Note: If a special Neutral Sound (i.e. Steam Water Injector, Steam Blow Down, Steam Pop-off, etc.) is occurring when you press one of the Function Keys that control any other special Neutral Sound, it will start the effect associated with that Function Key and will terminate the feature that was previously playing.

²¹ If Cruise Control is not available on your model, you will hear a Long Air Let-off when F9 is pressed for a moving locomotive.

2 Programming

There are two types of operation for a DCC equipped locomotive: Operations Mode and Service Mode.

1. **Operations Mode**²² (Ops Mode) is used to operate your train on a layout but it can also be used for programming the locomotive's decoder to customize it for your operating preferences.
2. **Service Mode**²³ is used exclusively for programming your locomotive and, depending on your command station, can provide feedback on values entered into the decoder.

Service Mode is done on a special track called a "Programming Track" while Operations Mode Programming can be done anywhere on the layout. In either case, programming involves changing the values of parameters called Configuration Variables (CV's) that will change the operation of your locomotive. Both programming modes have their advantages and disadvantages. Which one you use will depend on your personal preferences, the layout you are operating on, and the capabilities of your command station. Both Service Mode and Operations Mode programming are described in detail in later sections.

2.1 Configuration Variables Explained

Configuration Variables or (CV's) are settings stored in the Quantum's non-volatile memory²⁴ that affects how your locomotive operates. These variables can be programmed and reprogrammed as often as needed by the user to customize the locomotive's behavior. The CV values will be maintained indefinitely in memory until they are reprogrammed or the Quantum System memory is reset.

There are over 70 standard CV's described by the NMRA that can be programmed by the user. These CV's have been preset at the factory to provide the best operation right out of the box. Other locomotives may have different values and additional CV's. Programming of CV's is described in the following section.

Typical Factory Default Settings for Quantum Equipped Locomotives

Short Address	03
Speed Steps	28 or 128
Throttle Mode ²⁵	Standard Throttle Control (STC)
V-Start	32
V-High	1 - disabled
Acceleration	0
Braking (Deceleration)	0
Consist Address	0
Speed Table	N/A
System Volume	100%
Doppler Effect with F6	Enabled
CV Verbal Feedback	Enabled

Check the Operation Manual supplied with your locomotive for a list of factory defaults and features that are supported.

2.2 Service Mode Programming

One method provided by the NMRA to program all CV's is called Service Mode. The locomotive is placed on an isolated track, called a Programming Track that is electrically insulated from the main line and separately connected to a special output from your Command Station. There are advantages to programming in Service Mode.

²² Both the short form and the long form of the CV access instructions are supported.

²³ All four methods are supported: Address-Only Mode, Physical Register Addressing Mode, Paged CV Addressing Mode, and Direct CV Addressing Mode.

²⁴ CV memory is retained even when the locomotive is stored without power for up to one hundred years.

²⁵ Speed Control was only available on Lionel H0 and some early BLI locomotives.

1. No Locomotive Addresses are required to program your locomotive on the Programming Track. This is an advantage if you have forgotten your locomotive's ID numbers or have programmed them incorrectly. This is also why programming must be done on an isolated track section. Otherwise, all locomotive's CV's on your layout would be programmed with the same value at once.
2. NMRA specified acknowledgements are available from the locomotive on the Programming Track. If your command station supports Service Mode Acknowledgements, you will be able to read back the current value in a CV. This is an advantage if you want to change a CV by some amount but need to know where you are starting from before you enter a new value. It is also reassuring to receive some feedback from your locomotive during CV programming to know that programming is actually happening. Verbal feedback is not available from Quantum equipped locomotives in Service Mode.

The NMRA specifications for Acknowledgements are that at least a 60 milliamp (mA) differential current load must be applied by the locomotive on the Programming Track when the Command Station requests an acknowledgement. Most decoders, including the Quantum System, turn on the motor briefly to produce this load. A differential current load means that the current must increase by at least 60 mA over the current that is normally applied to the locomotive on the Programming Track to operate the decoder. The command station can sense this current increase and register this as an acknowledgement to its query. **The Quantum System conforms to the NMRA standard for Service Mode programming.**

Note: Some Command Stations have restricted the amount of power that can be delivered to the Programming Track to prevent damage to improperly installed aftermarket decoders. If the decoder were wired correctly, the Programming Track would provide enough power to allow it to be programmed. If the decoder were wired incorrectly and a short circuit occurred, the limited current from the command station would not be enough to damage the decoder, allowing the operator another chance to wire it correctly.

In order to accommodate command stations that do restrict power during Service Mode programming, the Quantum System reduces its power consumption to a minimum by shutting off all lights, sound and other operations during Service Mode operation. Even so, the Quantum Sound Decoder will still require more current than most non-sound decoders. If your Quantum System will not program with your particular command station, you will need to program on the Main (Ops Mode Programming). You can also purchase from Tony's Train Exchange²⁶, a simple, inexpensive power booster (PowerPak™ by DCC Specialties) that will allow you to program on the program track with any DCC command station.

²⁶ Tony's Train Exchange; 1-800-978-3472; info@ttx-dcc.com .

2.3 Operations Mode Programming

Operations Mode CV Programming is fully supported. Operations Mode is also called Ops Mode or Programming on the Main since no Programming Track is required.

Quantum System will allow the user to program all CV's including address CV's (CV 1, CV 17 and CV 18) in Operations Mode.

As with Service Mode, there are advantages and disadvantages to using Operations Mode Programming.

- 1) No advanced acknowledgement mechanism, as defined by the NMRA, is currently supported in Ops Mode Programming. If you are using a command station that provides readout for your CV's in Ops Mode, it can only indicate which CV you are addressing and the value you want to program. You will not be able to determine what value is already entered in that CV or that the new value has been accepted and is correct.

Note: The Quantum System does provide verbal feedback when programming CV's in Ops mode. If a CV verbal acknowledgment (CV 62) is enabled, the CV number and its value is announced over the Quantum sound system when a CV is programmed.

Note: The Quantum System also provides a way to query any specified CV for its present value in Ops Mode (CV 64).

- 2) One disadvantage with Programming on the Main is that you will need to address your locomotive with its ID number before you can change CV values. The disadvantage is not that an extra step is required to enter the ID number; rather the problem is that you might enter a new ID number incorrectly or you might have forgotten your ID number altogether. Since we do support Ops Mode programming for changing any CV, it could happen that you find yourself unable to communicate with your locomotive. If this does happen, you can either move your locomotive to a Programming Track and change your ID using Service Mode Programming, or you can do a hardware reset by pulling the reset jumper on the circuit board or using the Magnetic Wand²⁷, which will set the locomotive's ID to short address 3. (See Appendix IIIB).

Note: Some command stations do not support programming ID's on the main. See notes in troubleshooting and related CV's (1, 17, 18, 56.129) for possible solutions to this problem.

- 3) One advantage of programming on the main is that you will be able to hear the actual System Volume or individual feature sound volumes change immediately as you enter new CV values. In Service Mode, you would have to remove the locomotive from the Service Mode Programming track and "test it out" on the Main to see if it is the value you want.

²⁷ A magnetically activated switch on the circuit board replaced the jumper on later Quantum equipped locomotives.

2.4 List of NMRA CV's Support by Quantum

The following table lists all CV's. The NMRA (3rd column) indicates whether these CV's are mandatory (M), recommended (R), or optional (O). The fourth column indicates if this CV is supported by QSI and the fifth column indicates the common default value.

CV#	CV Name	NMRA	QSI Supported	Default Value Decimal	Comment
1	Primary Address	M	Y	3	
2	V-Start	R	Y	32	This number may change from locomotive to locomotive.
3	Acceleration Rate	R	Y	0	
4	Deceleration Rate	R	Y	0	
5	V-High	O	Y	1	Either 1 or 0 in this CV will disable V-High
6	V-Mid	O	N	-	
7	Manufacturer Version No.	M	Y	-	See CV 56.254 and CV 56.255 for additional information on Quantum Version numbers.
8	Manufacturer's ID	M	Y	113	
9	Total PWM Period ²⁸	O	N	-	Not needed with our motor control.
10	EMF Feedback Cutout2	O	N	-	Not needed with our BEMF detection.
11	Packet Time-Out Value	R	Y	1	About 1 second
12	Power Source Conversion	O	N	-	
13	Analog Mode Function Status	O	N	-	
14	Reserved by NMRA for future use	-	-	-	
15	Reserved by NMRA for future use	-	-	-	
16	Reserved by NMRA for future use	-	-	-	
17	Extended Address	O	Y	0	CV 17 and 18 form a paired CV. CV 17 must be written first followed by CV 18
18	Extended Address	O	Y	0	See above.
19	Consist Address	O	Y	0	
20	Reserved by NMRA for future use	-	-	-	
21	Consist Address Active for F1-F8	O	Y	0	
22	Consist Address Active for FL	O	Y	0	
23	Acceleration Adjustment	O	Y	0	
24	Deceleration Adjustment	O	Y	0	
25	Speed Table Selection	O	Y	2	Linear
26	Reserved by NMRA for future use	-	-	-	
27	Reserved by NMRA for future use	-	-	-	
28	Reserved by NMRA for future use	-	-	-	
29	Configuration Data #1	M	Y	6	28 speed step mode. Power Source Conversion enabled.
30	Error Information	O	N	-	May be used in the future but not currently needed.
31	Configuration Data #2	O	N	-	Reserved by NMRA for future use.
32	Configuration Data #3	O	N	-	Reserved by NMRA for future use.
33	Output Function Location for FL(f)	O	Y	1	By default set to directional lighting.
34	Output Function Location for FL(r)	O	Y	3	By default set to directional lighting.
35	Output Function Location for F1	O	Y	4	By default set to bell output
36	Output Function Location for F2	O	Y	8	By default set to whistle output.

²⁸ Changes are not allowed. The PWM is already optimized for Quantum equipped locomotives.

37	Output Function Location for F3	O	Y	16	
38	Output Function Location for F4	O	Y	4	
39	Output Function Location for F5	O	Y	8	
40	Output Function Location for F6	O	Y	16	
41	Output Function Location for F7	O	Y	32	
42	Output Function Location for F8	O	Y	64	
43	Output Function Location for F9	O	Y	16	
44	Output Function Location for F10	O	Y	32	
45	Output Function Location for F11	O	Y	64	
46	Output Function Location for F12	O	Y	128	
47	Reserved by NMRA for future use	-	-		
48	Reserved by NMRA for future use	-	-		
49	QSI Primary Index	O	Y	0	
50	QSI Secondary Index	O	Y	0	
51	QSI System Sound Control	O	Y		
52	QSI Individual Sound Volume Control	O	Y		
53	QSI Function Output Feature Assignment	O	Y		
54	Reserved by QSI for future use	-	-		
55	QSI Feature Configuration	O	Y		
56	QSI Configuration	O	Y		
57	Reserved by QSI for future use	-	-		
58	Reserved by QSI for future use	-	-		
59	Reserved by QSI for future use	-	-		
60	Reserved by QSI for future use	-	-		
61	Reserved by QSI for future use	-	-		
62	QSI Control	O	Y	1	
63	Reserved by QSI for future use	-	-		
64	Verbal CV Inquiry	O	Y		
65	Kick Start	O	N	-	
66	Forward Trim	O	Y	128	
67	Speed Step 1	O	Y	0	
68	Speed Step 2	O	Y	9	
69	Speed Step 3	O	Y	18	
70	Speed Step 4	O	Y	28	
71	Speed Step 5	O	Y	37	
72	Speed Step 6	O	Y	47	
73	Speed Step 7	O	Y	56	
74	Speed Step 8	O	Y	66	
75	Speed Step 9	O	Y	75	
76	Speed Step 10	O	Y	85	
77	Speed Step 11	O	Y	94	
78	Speed Step 12	O	Y	103	
79	Speed Step 13	O	Y	113	
80	Speed Step 14	O	Y	122	
81	Speed Step 15	O	Y	132	
82	Speed Step 16	O	Y	141	
83	Speed Step 17	O	Y	151	
84	Speed Step 18	O	Y	160	
85	Speed Step 19	O	Y	170	
86	Speed Step 20	O	Y	179	
87	Speed Step 21	O	Y	188	
88	Speed Step 22	O	Y	198	

89	Speed Step 23	O	Y	207	
90	Speed Step 24	O	Y	217	
91	Speed Step 25	O	Y	226	
92	Speed Step 26	O	Y	236	
93	Speed Step 27	O	Y	245	
94	Speed Step 28	O	Y	255	
95	Reverse Trim	O	Y	128	
96	Reserved by NMRA for future use	-	-		
97	Reserved by NMRA for future use	-	-		
98	Reserved by NMRA for future use	-	-		
99	Reserved by NMRA for future use	-	-		
100	Reserved by NMRA for future use	-	-		
101	Reserved by NMRA for future use	-	-		
102	Reserved by NMRA for future use	-	-		
103	Reserved by NMRA for future use	-	-		
104	Reserved by NMRA for future use	-	-		
105	User Identifier #1	O	N		
106	User Identifier #2	O	N		
107	Reserved by NMRA for future use	-	-		
:	:	-	-		
512	Reserved by NMRA for future use	-	-		

3 CV Descriptions - Overview

This section provides detailed descriptions of each CV supported by the Quantum System. Each CV on the following pages shows the default value, a pictorial of the CV data register and notes regarding its use, limitations, explanations and operational hints, when appropriate.

The data for each bit shown in the pictorial data registers are classified as:

- “**A**” for Address data
- “**D**” for general data
- “**F**” for Function Designation value
- “**Sign**” for plus or minus sign.
- “**N/A**” for Not Applicable meaning the user is not to enter data in these bits.
- “**Output**” for assigning different Output locations for Function Inputs.
- “**P**” for QSI Primary Index values
- “**S**” for QSI Secondary Index values
- “**V**” for audio volume data

In addition, QSI or NMRA pre-assigned data for individual bits in CV registers are shown as their binary value, “1” or “0”.

Examples:

CV 1: Primary Address Register

Bit 7	Bit 6	Bit 5	Bit 4	Bit 3	Bit 2	Bit 1	Bit 0
0	A6	A5	A4	A3	A2	A1	A0

Bits 0-6 are data bits, which specify the locomotives seven bit Primary Address. A zero means, “Do not attempt to write a 1 to this bit”.

CV 49: Primary Index Register

Bit 7 (MSB)	Bit 6	Bit 5	Bit 4	Bit 3	Bit 2	Bit 1	Bit 0 (LSB)
P7	P6	P5	P4	P3	P2	P1	P0

Bits 0-7 are data bits, which specify any of the possible eight bit Primary Index values.

CV 40: F6 Output Function Location for F6 Register (with Factory Default Features)

Cruise Control (Disconnect-Standby-Total Shut Down)	Mute	Squealing Brakes – Air Brakes (Brake Set)	Doppler (Start Up)	Dynamic Brakes	Blower Hiss/Fans	Coupler Crash Coupler Fire (Coupler Arm)	Whistle/Horn
Bit 7	Bit 6	Bit 5	Bit 4	Bit 3	Bit 2	Bit 1	Bit 0
Output 11	Output 10	Output 9	Output 8	Output 7	Output 6	Output 5	Output 4

The “**Output 4**” means that bit 0 specifies whether Output 4 is controlled by Function Key 6.

Gray background for an Output bit means that it is the default setting.

3.1 CV 1 Primary Address Control

Programs Quantum Short or Primary Address from 1 to 127 decimal.

Default Value:

3

CV 1: Primary Address Register

Bit 7	Bit 6	Bit 5	Bit 4	Bit 3	Bit 2	Bit 1	Bit 0
0	A6	A5	A4	A3	A2	A1	A0

- Writing to this CV sets Quantum's Primary Address to any value between 1 and 127. The Quantum System will process any valid command sent by the base station with an address that matches the address stored in this register.
- Any attempt to set this CV to any value outside the range of 1 to 127 will be ignored and the previous address in this register will remain.
- The Primary Address can be set either in Service Mode or Operations Mode. Remember to change bit 5 of CV 29 to "0" to enable the Primary Address.

Note: Some Command Stations will not operate Quantum Systems in Service Mode due to insufficient power output or timing problems. (Check Appendix IIIA for a listing of recommended command stations). If you cannot operate in Service Mode, use Ops Mode programming.

If your command station will not allow setting ID numbers in Ops Mode, use QSI CV 56.129.

3.2 CV 2 V-Start

V-Start defines the voltage drive level applied to the motor at the first throttle speed step.

Default Value:

CV 2: V-Start Register

Bit 7	Bit 6	Bit 5	Bit 4	Bit 3	Bit 2	Bit 1	Bit 0
D7	D6	D5	D4	D3	D2	D1	D0

- This register sets a start voltage for the motor to any value between 0 and 255 (0 – 0xFF). A value of 0 provides no offset while a value of 255 provides maximum starting voltage with no throttle range left.

This register specifies how much of the available track voltage will be applied to the motor at the start of the throttle range. While the “0” speed step still provides no motor drive, the “2” speed step provides a starting voltage to the motor defined by the following equation:

$$\text{Start Voltage} = (\text{Track Voltage}) \times (\text{CV2}/255)$$

Note that the value of this register is not an offset to the speed step. For instance, a value of “5” does not mean that the throttle speed step is offset by five and represents a speed step of six for the first speed step.

- The value of motor drive (as a percentage of total track voltage) is computed according to the formula below:

$$\% \text{ Applied Motor Voltage} = \left\{ \text{CV 2} + \frac{(\text{CV 5} - \text{CV 2}) \times (\text{Speed Table Value for speed step})}{255} \right\} \times \frac{100}{255}$$

This produces an offset percentage equal to $\{\text{CV2}/255\} \times 100\%$ plus the percentage increase from the speed table curve reduced by the offset percentage. The result is that this curve starts at the desired offset but ends up at the same maximum value (CV 5). The graph below shows the original curve plus the effect of an offset of 20% (CV 2 = 51 and CV 5, V-High, is set at its maximum value of 255).

Note: If CV 5 is less than or equal to CV 2, or CV 5 set to 0 or 1, then 255 is used for CV 5 in the above equations.

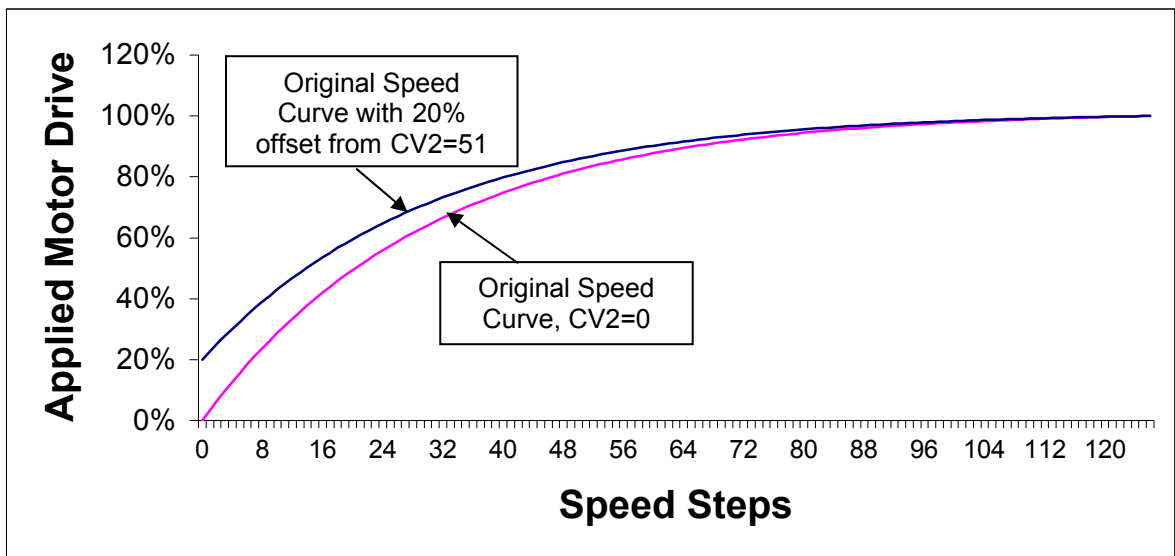

3.3 CV 3 Acceleration Rate²⁹

Sets Quantum value of Inertia Under Acceleration

Default Value:

0

CV 3: Acceleration Rate Register

Bit 7	Bit 6	Bit 5	Bit 4	Bit 3	Bit 2	Bit 1	Bit 0
D7	D6	D5	D4	D3	D2	D1	D0

- Acceleration rate register can have any rate between 0 and 255. A value of “0” provides no inertia and gives the fastest response to changes in throttle position.
- When any number except “0” is entered in CV 3, the power applied to the motor increases linearly as a function of time between speed steps. The inertia in “seconds per speed step” is based on the value of CV 3 as provided by the formula below.

$$\text{Acceleration Inertia (Seconds/speed step)} = \frac{(\text{CV 3}) * 0.896}{\text{Number of Speed Steps}}$$

- Note that the value of CV 3 will provide the same inertia for all speed step choices (14, 28, and 128) for the same percentage change in throttle position. In other words, for the same value of CV 3, it will take the same amount of time to go from a dead stop to full speed for a throttle change from minimum to maximum regardless of the speed step choice. The acceleration rate can vary from a quick response measured in seconds for CV 3=0 to as long as 3.8 minutes (228 seconds) for CV 3 = 255.
- The actual acceleration is the inverse of the above inertia formula.

$$\text{Acceleration (speed steps/second)} = \frac{\text{Number of speed steps}}{(\text{CV 3}) * 0.896}$$

- The acceleration and deceleration rate values in CV 3 and CV 4 will apply if you change the direction on a moving locomotive. The locomotive will slow to a stop at a rate set by CV 4 and then accelerate in the opposite direction at a rate set by CV 3.

²⁹ This NMRA CV is more aptly entitled “Inertia under Acceleration” since higher values for this CV result in higher inertia values but lower acceleration rates. Using the term “Momentum” to describe CV 3 is not correct since a non-moving train has no momentum even if CV 3 is set to the maximum value. Inertia is the property of an object that resists any change to its state of rest or motion.

3.4 CV 4 Deceleration Rate³⁰

Sets Quantum Inertia Under Deceleration.

Default Value:

CV 4: Deceleration Register

Bit 7	Bit 6	Bit 5	Bit 4	Bit 3	Bit 2	Bit 1	Bit 0
D7	D6	D5	D4	D3	D2	D1	D0

- Deceleration rate register can have any rate between 0 and 255. A value of “0” provides no inertia and gives the fastest response to changes in throttle position.
- When any number except “0” is entered in CV 4, the power applied to the motor decreases linearly as a function of time between speed steps. The amount of seconds per speed step is based on the value of CV 4 as provided by the formula below.

$$\text{Deceleration Inertia (Seconds/speed step)} = \frac{(\text{CV 4}) * 0.896}{\text{Number of Speed Steps}}$$

- Note that the value of CV 4 will provide the same inertia for all speed step choices (14, 28, and 128) for the same percentage change in throttle position. In other words, for the same value of CV 4, it will take the same amount of time to go from full speed to a dead stop for a throttle change from maximum to minimum regardless of the speed step choice. The deceleration rate can vary from the time it takes the model locomotive running at full speed to stop (a second or so) for CV 4 = 0, to as long as 228 seconds (3.8 minutes) for CV 4 = 255.
- The actual deceleration is the inverse of the above formula.

$$\text{Deceleration (speed steps/second)} = \frac{\text{Number of speed steps}}{(\text{CV 4}) * 0.896}$$

- The acceleration and deceleration rate values in CV 3 and CV 4 will apply if you change the direction of a moving locomotive. The locomotive will slow to a stop at a rate set by CV 4 and then accelerate in the opposite direction at a rate set by CV 3.

³⁰ This NMRA name is more aptly entitled “Inertia under Deceleration” since higher values for this CV result in higher inertia values but lower deceleration rates. Using the term “Momentum” to describe CV 3 is not correct since a non-moving train has no momentum even if CV 3 is set to the maximum value. Inertia is the property of an object that resists any change to its state of rest or motion.

3.5 CV 5 V-High

V-High defines the voltage drive level applied to the motor at maximum throttle. Use CV 5 to reduce the maximum speed of locomotives that operate too fast at maximum throttle.

Default Value:

CV 5: V-High Register

Bit 7	Bit 6	Bit 5	Bit 4	Bit 3	Bit 2	Bit 1	Bit 0
D7	D6	D5	D4	D3	D2	D1	D0

- This register sets a maximum voltage for the motor to any value between 2 and 255 (0 – 0xFF). A value of 0 or 1 or 255 provides maximum motor voltage at maximum throttle.

The value of this register determines the maximum motor drive as a fraction of the applied voltage as defined by the following equation:

$$\text{Maximum Motor Voltage} = (\text{Track Voltage}) \times (\text{CV5}/255)$$

For instance, a value of “200” for CV 5 means that the maximum voltage will be 217/255 or 85% of the applied track voltage.

The value of motor drive (as a percentage of total track voltage) is computed according to the formula below:

$$\% \text{ Applied Motor Voltage} = \{ \text{CV 2} + (\text{CV 5} - \text{CV 2}) \times \frac{(\text{Speed Table Value for speed step})}{255} \} \times \frac{100}{255}$$

While CV 2 determines the offset percentage, CV 5 determines the maximum percentage of the track voltage applied to the motor. The result is that the shape of the original speed curve from the speed table is preserved but compressed to fit between V-Start and V-High. The graph below shows the effect of only CV 5 (CV 2 =0) on the original curve. Here a value of CV 5 = 217 reduces the original speed curve by 15% over the entire speed step range.

If CV 5 is less than or equal to CV 2, or CV 5 set to 0 or 1, then 255 is used for CV 5 in the above equations.

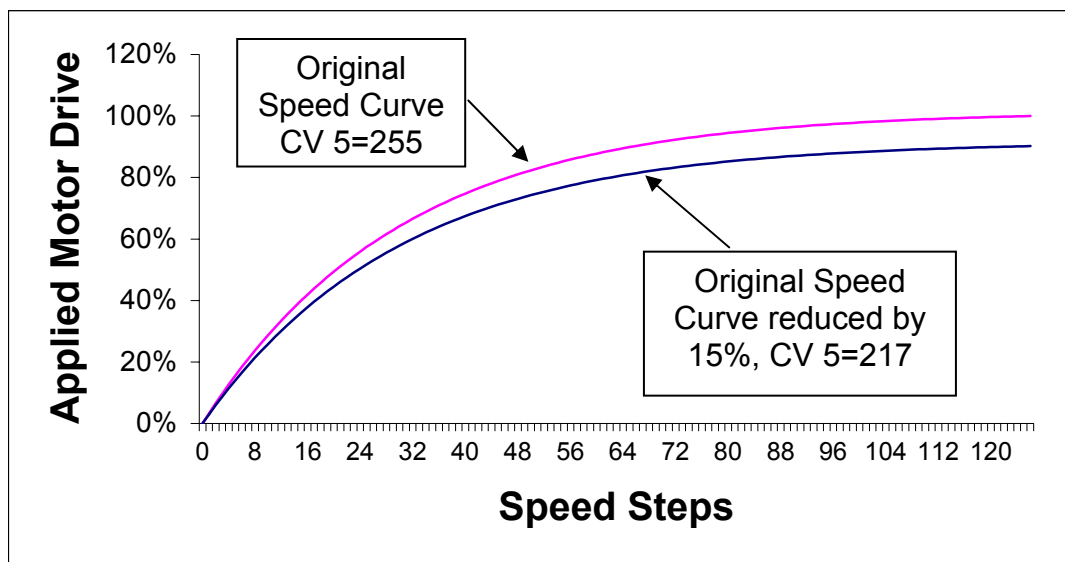

V-High is not related to V Max for Analog Operation.
 V-High is not used when Throttle Mode = Speed Control.

Recommendations for specifying speed curves, V-Start and V-High.

The following is a method we have used to program a locomotive to match the speed of other locomotives at QSI. This method uses Ops mode programming since it will let you program your locomotives speed characteristics while the locomotive is operating.

1. Set CV 56.4 to 0 or 1, which will set the throttle control mode to either Standard Throttle Control or Regulated Throttle Control.
2. Set CV 29, bit 4, to 1 to enable speed curves.
3. Set different locomotive ID numbers for Locomotive A and Locomotive B.
4. Place your locomotive to be programmed (call it Locomotive A) on a fairly large loop of track. Also place your standard locomotive³¹ (call it Locomotive B) that you use as your speed reference on the same loop of track but on the opposite end. Both locomotives should have different ID's.
5. Select and start your standard Locomotive, B, moving at speed step 1 and select and start your Locomotive A to be programmed, also moving at speed step 1.
6. Enter in Ops mode programming for Locomotive A. Set CV 2 values until Locomotive A is moving at the same speed as Locomotive B.
7. Leave Ops mode programming. Select and run your standard locomotive at full throttle and quickly do the same with Locomotive B. You may have to temporarily restrain one of the locomotives if they get too close to each other.
8. Enter in Ops mode programming for Locomotive A. Set CV 5 values until Locomotive A is moving at the same speed as Locomotive B.
9. Leave Op mode programming. Set both Locomotive A and Locomotive B to speed step 128. Enter Ops mode programming for Locomotive A and select CV 25. Choose speed curves from the list of QSI speed from CV 25 until both locomotives are running at a similar speed. These speed curves will be compressed to fit between V-High and V-Start as shown in the graph below.

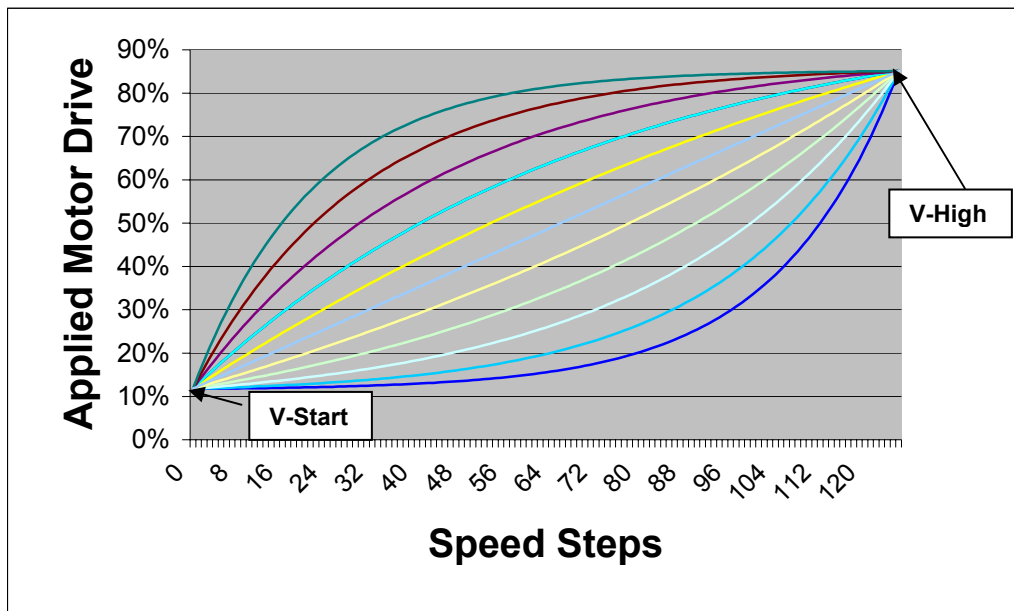

Speed Curves with V-Start set to 30 (10% of applied voltage) and V-High set to 217 (85% of applied voltage).

10. If none of the speed curves are acceptable, set CV 25 to 1 and make your own custom speed curve using CV 67 through CV 94. Your custom speed curve will also be compressed to fit within the limits set by V-Start and V-High.

³¹ You may have a number of standard locomotives for different speed classifications. For instance, you might have a standard locomotive for yard operations with a top speed of 35 smph, a standard freight locomotive with a top speed of 65 smph and a third standard locomotive for passenger service with a top speed of 100 smph.

Set both locomotives at 28 speed-step selection so your custom changes are at the speed step the locomotive is operating at. Start both locomotives at speed step 1; enter Ops mode programming for Locomotive A and set CV 67 to match Locomotive B speed. Leave Ops mode programming, and set both locomotives to operate at speed step 2, enter Ops mode programming for Locomotive B and set CV 68 to match Locomotive B speed. Repeat this procedure until you have entered speed curve values for all CV's between CV 67 and CV 94.

3.6 CV 7 Manufacturer's Version Number

This is a read only CV that provides information regarding the version number of the software released for this locomotive.

Default Value:

N/A

CV 7: Manufacturer's Version Number Register

Bit 7	Bit 6	Bit 5	Bit 4	Bit 3	Bit 2	Bit 1	Bit 0
D7	D6	D5	D4	D3	D2	D1	D0

- Version releases start with 1. If you have a 1 in this register, this is the first version of Quantum HO software released. If you have a "2" it is the second version of Quantum HO software released.

3.7 CV 8 Manufacturer's ID

This read-only CV identifies QSI as the manufacturer or developer of the software used in the Quantum System.

Default Value:

113

CV 8: Manufacturer's ID Register

Bit 7	Bit 6	Bit 5	Bit 4	Bit 3	Bit 2	Bit 1	Bit 0
0	1	1	1	0	0	0	1

- The value of this read only register is 113, which is the official NMRA designation for QSI as a manufacturer of DCC decoders.

3.8 CV 11 Packet Time-Out Value

The value in CV 11 is the maximum time Quantum will maintain its current speed without receiving a valid DCC packet.

Default Value:

1

CV 11: Packet Time-Out Value Register

Bit 7	Bit 6	Bit 5	Bit 4	Bit 3	Bit 2	Bit 1	Bit 0
N/A	N/A	N/A	D4	D3	D2	D1	D0

- If CV 11 has a non-zero value, and the locomotive receives no DCC packets addressed to the locomotive for that number of seconds then the locomotive will decelerate to a stop at a rate specified by CV 4 and CV 24 and will enter Neutral. The usual Neutral Sounds will then be heard.
- When DCC packets addressed to the locomotive are again received, the locomotive will respond to the DCC packet commands addressed to the locomotive. It will remain in Neutral until a new speed packet is received at which time it will accelerate at the rate set in CV 3 and CV 23.
- A value of zero will disable the time-out function and the locomotive will continue to run at its last speed setting when it stops receiving packets addressed to the locomotive.
- The factory default is “1” which is interpreted as 1 second.
- The maximum value for CV 11 is 20, interpreted as 20 seconds³². If any value greater than 20 is written to this CV, the new value is ignored and CV11 retains its previous value.
- If both Power Source Conversion (CV 29, bit 2) and Packet time-out Value are enabled, Power Source Conversion takes precedence, since it will always have the shorter time-out period.

³² Twenty seconds is the maximum time specified in NMRA Recommended Practice RP-9.2.4.

3.9 CV 17, 18 Extended Address

CV 17 and CV 18 together provide a larger (14 bit) range for locomotive ID numbers from 0 to 10,239.

CV 17 Default Value:	0 ³³
CV 18 Default Value	0

CV 17: Extended Address Most Significant Byte Register

Bit 7	Bit 6	Bit 5	Bit 4	Bit 3	Bit 2	Bit 1	Bit 0
1	1	A13	A12	A11	A10	A9	A8

CV 18: Extended Address Least Significant Byte Register

Bit 7	Bit 6	Bit 5	Bit 4	Bit 3	Bit 2	Bit 1	Bit 0
A7	A6	A5	A4	A3	A2	A1	A0

- CV 17 and CV 18 Extended or Long Address allows the operator to enter one of 10,240 addresses from 0 to 10,239 although most Command Stations will only allow entering ID's up to 9,999. The advantage of the Extended Address is that ID's can be identical to the locomotive cab numbers, which rarely exceed four digits.
- Setting an Extended Address in CV 17 and CV 18 does not eliminate the Primary Address in CV 1. Since there is overlap in the range between Primary Addresses and Extended Addresses, a Primary Address may have the same number as an Extended Address but these addresses are not the same and are addressed differently from your Command Stations (see your Command Station Instructions).
- The Extended Address can be set either in Service Mode or Operations Mode. Remember to change bit 5 of Configuration CV 29 to "1" to enable the Extended Address.
- **Entering Extended Address into CV 17 and CV 18 Directly:** Most modern Command Stations allow the operator to input an Extended Address from 0 to 9999 directly in decimal format without having to individually enter data into CV 17 and CV 18. However, if you have an older Command Station and need to program these CV's directly, the following information will be helpful.

CV 17 and CV 18 form a paired CV and it makes a difference how data is entered. CV 17, the most significant byte, must be written first followed by CV 18, the least significant byte. If the order is reversed, the Quantum decoder will not accept the values entered.

Bits A15 and A14 must both be assigned "1" which adds 192 to the value of the byte in CV 17. The remaining 6 bits of C17 and the 8 bits of C18 allow addresses to be assigned between 0 and 10,239 inclusive. Any attempt to program an extended ID above 10,239 will be ignored.

If your Command Station will not allow you to enter Extended Addresses as a decimal number, you will need to enter CV 17 and CV 18 by direct programming. To enter your extended ID, first divide the decimal address you intend to enter by 256, and convert the quotient to binary and add the two leading 1's for bits A14 and A15 and write to CV 17. Convert the remainder to binary and write this number to CV 18. If you enter either number in hex or decimal, make sure you convert CV 17 with the two leading binary 1's in bits A14 and A15.

33 The default for CV 17 is actually "192" which is an artifact of how these ID numbers are specified by the NRMA where 192 is added to the MSB (Most Significant Byte) of the address you want to enter. If you have a modern Command Station that programs your ID numbers directly, you will enter your ID number equal to the Extended Address you intend to use; however, if you program the extended address CV directly, a zero address must be entered as 192. See example in this section on directly programming CV 17 and CV 18.

Example1 Decimal Entry: Program CV 17 and CV 18 to Extended Address 5343.

Divide 5343 by 256 to get 20 as quotient and 223 as remainder.

Note: If you use a calculator, you will get 20.8711. Note the integer value $n = 20$, which is the quotient.

Add 192 to this quotient to get 212 and store this value in CV 17:

$$\text{CV 17} = n + 192$$

$$\text{CV 17} = 20 + 192 = 212$$

Compute the remaining integer value by multiplying 20 by 256 and subtract from the locomotive value to get remainder and store in CV 18:

$$\text{CV 18} = \text{Locomotive Number} - (n \times 256)$$

$$\text{CV 18} = 5343 - (20 \times 256) = 223$$

Remember to change CV 29, bit 5 to "1" to allow the Extended Address operation (see CV 29).

Example2 Binary or Hex Entry: Program CV 17 and CV 18 to Extended Address 5343.

Convert 212 from previous example to binary 11010100 or hex 0xD4. Enter this number in CV 17.

Convert 223 from previous example to binary 11011111 or hex 0xDF and enter in CV 18.

Remember to change CV 29, bit 5 to "1" to allow the Extended Address operation (see CV 29).

To check: Compute $(\text{CV 17} - 192) \times (256) + \text{CV 18}$ where 192 is the decimal equivalent of CV 17 with only the leading 1's (11000000)

Decimal: $(212 - 192) \times (256) + 223 = \mathbf{5343}$

Binary: $(11010100 - 11000000) \times (100000000) + 11011111 = 101001101111 = \mathbf{5343}$ decimal.

Hex: $(0xD4 - 0xC0) \times 0x100 + 0xDF = 0x14DF = \mathbf{5343}$ decimal, where 0xC0 is the hex equivalent of 192.

The following table shows examples for some common Steam locomotive cab numbers. See if your calculations match the values in the table. After you have calculated your ID numbers, just follow the procedure below to enter your extended ID number.

- 1) Find out if your command station accepts Decimal, Binary or Hex inputs for CV entries.
- 2) First enter CV 17 (Most Significant Byte) from the table below as a Decimal, Binary or Hex number shown.
- 3) Next enter CV 18 (Least Significant Byte) from the table below as a Decimal, Binary or Hex number shown.
- 4) Change CV 29, bit 5 to "1" to allow operation with your new Extended Address.
- 5) Read your ID number back from your program track or verbally in Opts Mode to see if you entered the correct number.

Common Steam Engine Numbers

Loco Number	CV 17 (Dec)	CV 18 (Dec)	CV 17 (Hex)	CV 18 (Hex)	CV 17 (Binary)	CV 18 (Binary)
3985	207	145	CF	91	11001111	10010001
611	194	99	C2	63	11000010	01100011
8444	224	252	E0	FC	11100000	11111100
4449	209	97	D1	61	11010001	01100001
3751	206	167	CE	A7	11001110	10100111
261	193	5	C1	5	11000001	00000101
1218	196	194	C4	C2	11000100	11000010
1361	197	81	C5	51	11000101	01010001
700	194	188	C2	BC	11000010	10111100

Note: If your command station allows entering in decimal format, but requires separate entries for both CV 17 and CV 18, then you should follow the above procedure. However, if your Command Station will allow you to enter the ID's in decimal form in either CV 17 or CV 18 as a single four-digit number, do not follow the above procedure; simply enter your four-digit number as explained in your command station instruction manual.

Note: Some command stations will not operate Quantum Systems in Service Mode due to insufficient power output or timing problems. (Check Appendix II for a listing of recommended command stations). If you cannot operate in Service Mode, use Ops mode programming.

If your command station will not allow setting ID numbers in Ops Mode, use QSI CV 56.129 to enter your ID numbers.

3.10 CV 19 Consist Address

Sets a locomotive to a Consist³⁴ address in addition to setting the locomotive's direction within the Consist.

Default Value:

0

CV 19: Consist Address Active for FL and F9-F12 Register

Bit 7	Bit 6	Bit 5	Bit 4	Bit 3	Bit 2	Bit 1	Bit 0
D7	A6	A5	A4	A3	A2	A1	A0

- Bits A0-A6 set the Consist address to any value from 0 to 127.
- Bit D7 sets the locomotive's direction. "0" in D7 sets the locomotive to a normal Forward and "1" sets locomotive to Reverse Direction within the Consist.
- If the seven bit address in bits 0-6 is 0000000 the locomotive is not in the Consist. If any other address is entered and decoder receives a command packet that matches this Consist Address, the packet will be processed as any other packet except,
 - The direction bit in a speed/direction or advanced operation packet is inverted if D7=1.
 - Function Key behavior can be modified via CV's 21 and 22.
 - Long Form CV Access instructions will be ignored.
 - Only Short Form CV Access instructions for CV's 23 and 24 are allowed.
- If you intend to use a locomotive in a Consist and need to configure it for compatible operation in the Consist (e.g. setting the acceleration CV to be the same as other intended Consist locomotives, etc.), you can either change the appropriate CV's to their new values before you give it a Consist Address or you can address the individual locomotive within the Consist by its Primary or Extended Address and then change the appropriate CV's.
- If a locomotive has the same Consist ID as its Primary Address, it will respond to commands as through it were being addressed by its Locomotive Address without the restrictions set in CV 21 and CV 22.
- Take care not to use an address for a Consist that is the same as an enabled Primary Address in an individual locomotive somewhere else on your layout. Since there is no difference in the form of packet addresses sent to a Consist or an individual locomotive, both the Consist and isolated locomotive will process the commands and both will respond at the same time.

³⁴ Consists are also know as Multiple Heading, Lashups or Multiple Unit Trains (MU's) .

3.11 CV 21 Consist Address Active for F1-F8³⁵

Sets which Function Keys are enabled when a locomotive is addressed by its Consist ID.

Default Value:

0

CV 21: Consist Address Active for F1-F8 Register

Bit 7	Bit 6	Bit 5	Bit 4	Bit 3	Bit 2	Bit 1	Bit 0
F8	F7	F6	F5	F4	F3	F2	F1

If zeros are placed in any bit, that function key is disabled when the locomotive is addressed by its Consist ID. If a one is placed in any bit, that function key is enabled when the locomotive is addressed by its Consist ID.

This CV and CV 22 are useful for disabling certain features for helper locomotives within the Consist. For instance, only the Lead locomotive should have its Horn/ Whistle and Bell enabled. If the F2 key controls the Horn and the F3 key controls the Bell, then all slave locomotives should have "0" in Bit 1 and Bit 2, while the Lead locomotive should have "1" in these bits.

The following recommended values are for locomotives that have factory default features assigned to Function Outputs (see CV 53) . Features that are different in the Neutral State are shown with parentheses (i.e. Doppler (Start Up) means Doppler is only operable in Forward and Reverse and Start Up is operable only in Neutral). Features shown that do not indicate a special Neutral Option, will operate in all states (Forward, Neutral and Reverse).

Recommended value of CV 21 for a Lead Locomotive in a Consist.

(The QSI default features assignments are shown for Forward/Reverse operation in the top row and for Neutral in parenthesis).

Audio Mute	Brake Squeal and Air Brakes	Doppler (Start Up)	Dynamic Brakes	Blower Hiss/Fans	Coupler Crash Coupler Fire (Coupler Arm)	Whistle/Horn	Bell
Bit 7	Bit 6	Bit 5	Bit 4	Bit 3	Bit 2	Bit 1	Bit 0
1	1	1	1	1	0	1	1

³⁵ Write bit operation is supported for CV 21.

Recommended value of CV 21 for a Mid³⁶ Helper Locomotive in a Consist.

(The QSI default features assignments are shown for Forward/Reverse operation in the top row and for Neutral in parenthesis).

Audio Mute	Brake Squeal and Air Brakes	Doppler (Start Up)	Dynamic Brakes	Blower Hiss/Fans	Coupler Crash	Whistle/Horn	Bell
Bit 7	Bit 6	Bit 5	Bit 4	Bit 3	Bit 2	Bit 1	Bit 0
1	1	1	1	1	0	0	0

Recommended value of CV 21 for an End³⁷ Helper Locomotive in a Consist.

(The QSI default features assignments are shown for Forward/Reverse operation in the top row and for Neutral in parenthesis).

Audio Mute	Brake Squeal and Air Brakes	Doppler (Start Up)	Dynamic Brakes	Blower Hiss/Fans	Coupler Crash	Whistle/Horn	Bell
Bit 7	Bit 6	Bit 5	Bit 4	Bit 3	Bit 2	Bit 1	Bit 0
1	1	1	1	1	1	0	0

36 A Mid Helper is any locomotive between the Lead and the last or End helper in a Consist.
37 An End Helper is the last helper in a Consist.

3.12 CV 22 Consist Address Active for FL and F9-F12³⁸

Sets whether the FL(r) or FL(f) keys and F9-F12 keys are enabled when a locomotive is addressed by its Consist ID.

Default Value:

0

CV 22: Consist Address Active for FL and F9-F12 Register

Bit 7	Bit 6	Bit 5	Bit 4	Bit 3	Bit 2	Bit 1	Bit 0
0	0	F12	F11	F10	F9	FL(r)	FL(f)

- If “0’s” are placed in any of bits 0 through 5, the FL key is disabled when the locomotive is addressed by its Consist ID. If a “1” is placed in any of bits 0 through 5, that function key is enabled when the locomotive is addressed by its Consist ID. FL in the Forward Direction is controlled by bit 0; FL in the Reverse Direction is controlled by bit 1.
- Any “1” placed in bits 6 or 7 will be ignored.

This CV and CV 21 are useful for disabling certain features for Helper locomotives within the Consist. For instance, only the Lead Locomotive should have operational Directional Lighting. Helpers should have their Directional Lighting disabled.

F9, Cruise Control and Shut Down are recommended for all Helper types in a Consist since Cruise Control should apply to all locomotives or none at all; otherwise there would be fighting between locomotives that have Cruise Control enabled and those that do not. Similarly, the F9 Shut Down key should apply to all locomotives in Consist or none at all.

F10, Status Report should be disabled for all Helper types in a Consist since it would be difficult to hear the verbal announcement if more than one locomotive announced its status at the same time.

Features for Function keys 11 and 12 are usually reserved for Number Board Lights and Cab Lights. It is recommended that Cab Lights be disabled and Number Board Lights be enabled. At times F11 and F12 are reserved for custom appliance sounds or operations for the different locomotive types (Steam, Diesel or Electric) such as steam Blow Down, etc. It is recommended that these functions be disabled for all Helper types except the Lead Locomotive to avoid confusion. Check your individual models to determine which features are assigned to F11 and F12.

The following recommended values are for locomotives that have factory default values assigned to FL Function Outputs (see CV 53). Features that are different in the Neutral State are shown with parentheses (i.e. Cruise Control (Shut Down) means Cruise Control is only operable in Forward and Reverse and Shut Down is operable only in Neutral).

Recommended value of CV 22 for a Lead Locomotive in a Consist:

N/A	N/A	Cab Lights	Number Board Lights	SMPH Report (Status Report)	Cruise Control (Disconnect-Standby-Total Shut Down)	Directional Lighting	Directional Lighting
N/A	N/A	F12	F11	F10	F9	FL(r)	FL(f)
Bit 7	Bit 6	Bit 5	Bit 4	Bit 3	Bit 2	Bit 1	Bit 0
0	0	0	1	1	1	1	1

³⁸ Write bit operation is supported for CV 22.

Recommended value of CV 22 for a Mid Helper Locomotive in a Consist:

N/A	N/A	Cab Lights	Number Board Lights	SMPH Report (Status Report)	Cruise Control (Disconnect-Standby-Total Shut Down)	Directional Lighting	Directional Lighting
N/A	N/A	F12	F11	F10	F9	FL(r)	FL(f)
Bit 7	Bit 6	Bit 5	Bit 4	Bit 3	Bit 2	Bit 1	Bit 0
0	0	0	1	0	1	0	0

Recommended value of CV 22 for an End Helper Locomotive in a Consist:

N/A	N/A	Cab Lights	Number Board Lights	SMPH Report (Status Report)	Cruise Control (Disconnect-Standby-Total Shut Down)	Directional Lighting	Directional Lighting
N/A	N/A	F12	F11	F10	F9	FL(r)	FL(f)
Bit 7	Bit 6	Bit 5	Bit 4	Bit 3	Bit 2	Bit 1	Bit 0
0	0	0	1	0	1	0	0

When making up your consist, remember to have the directional lighting turned off before you assign zeros for bits 0 and 1. Otherwise the directional lighting will be on with no way to turn them off with the FL(r) or FL(f) keys³⁹.

The above selections for directional lighting for locomotives in a consist is not ideal for the following reasons:

1. You may not want the Lead Locomotive to have an operating Directional Reverse Light since it would only illuminate the locomotive behind it and not the track. To eliminate the Reverse Directional Lighting feature, assign Outputs 1 and 2 to Directional Headlight (Feature ID 96) in CV 53. With bits 0 and 1 in CV 22, the Front Directional Light will be controlled from either FL(f) or FL(r) and the Reverse Light will not operate at all.
2. You may want the End Helper to have an operational reverse facing light (which may be either the End Helper's Reverse Light or Headlight depending on the locomotive's direction within the consist). If the End Helper is facing Forward, Assign Outputs 1 and 2 to the Directional Reverse Light (Feature ID 97) in CV 53 and set bit 0 and bit 1 in CV 22 to 1. If the End Helper is facing Backwards, Assign Outputs 1 and 2 to the Directional Headlight (Feature ID 96) in CV 53 and set bit 0 and bit 1 in CV 22 to 1. The End Helper will now have a non-operating Headlight and an operating Directional Reverse Light that can be enabled with either the FL(f) or FL(r) key.

With the above changes, the directional lighting in your consist will operate like a single locomotive. That is, the FL key is on, the Lead Locomotive Directional Headlight will be on, all other Helper Headlights will be off, and all Reverse Lights will be off. If the Consist is moving in Reverse, only the End Helper Reverse Light will be on and the Lead Locomotive Headlight will either be off or Dim (if the Dim feature is part of the Directional Headlight for your model).

Alternately, for your End Helper, you could also set bits 0 and 1 to 0 in CV 23, along with the newly assigned lighting for outputs 1 and 2 (as described in item 1 above) and turn on the Directional Lighting by selecting the End Helper by its Locomotive ID. This would allow you to leave the End Helper Directional lighting disabled when the Consist was coupled to its train.

³⁹ Since the default for directional lighting is off, any helpers that did have their directional lighting on will be set to off if the power is turned off and back on, or if the locomotive is shut down and started using the F9 and F6 keys.

3.13 CV 23 Acceleration Adjustment

Increases or decreases the Acceleration from the base Acceleration Rate in CV 3.

Default Value:

0

CV 23: Acceleration Adjustment Register

Bit 7	Bit 6	Bit 5	Bit 4	Bit 3	Bit 2	Bit 1	Bit 0
Sign	D6	D5	D4	D3	D2	D1	D0

- CV 23 can have any value from -127 to +127 where positive values will increase the acceleration time and negative values will decrease the acceleration time. A positive value is indicated by a 0 in bit 7 while a "1" indicates a negative value.
- The value of CV 23 adds directly to the value of CV 3 by the formula below:

$$\text{Seconds/speed step} = \frac{(\text{CV 3} + \text{CV 23}) * 0.896}{\text{Number of Speed Steps}}$$

The purpose of CV 23 is to allow the operator to simulate differing train lengths/loads, most often when operating in Consists. It can, however, apply to single locomotives as well.

3.14 CV 24 Deceleration Adjustment

Increases or decreases the Deceleration from the base Deceleration Rate in CV 4.

Default Value:

0

CV 24: Deceleration Adjustment Register

Bit 7	Bit 6	Bit 5	Bit 4	Bit 3	Bit 2	Bit 1	Bit 0
Sign	D6	D5	D4	D3	D2	D1	D0

- CV 24 can have any value from -127 to +127 where positive values will increase the deceleration time and negative values will decrease the deceleration time. A positive value is indicated by a 0 in bit 7 while a "1" indicates a negative value.
- The value of CV 24 adds directly to the value of CV 4 by the formula below:

$$\text{Seconds/speed step} = \frac{(\text{CV 4} + \text{CV 24}) * 0.896}{\text{Number of Speed Steps}}$$

The purpose of CV 24 is to allow the operator to simulate differing train lengths/loads, most often when operating in Consists. It can, however, apply to single locomotives as well.

3.15 CV 25 Quantum Speed Table Selection

User selection of one of 11 speed curves.

Default Value: 2

CV 25: Quantum Speed Table Selection Register

Bit 7	Bit 6	Bit 5	Bit 4	Bit 3	Bit 2	Bit 1	Bit 0
0	D6	N/A	N/A	N/A	D2	D1	D0

- A number of speed tables are included with your Quantum system that can be directly used in place of the linear default table or user specified tables. The user is able to select from 11 different predefined speeds as shown in the graph below. The upper five convex curves show a choice of different “fast start” speed tables while the lower five concave curves are “slow start” speed tables. The “fast start” curves will compensate for locomotives that are less responsive getting started while the “slow start” curves compensate for locomotives that tend to “rocket out” when the throttle is barely turned on.

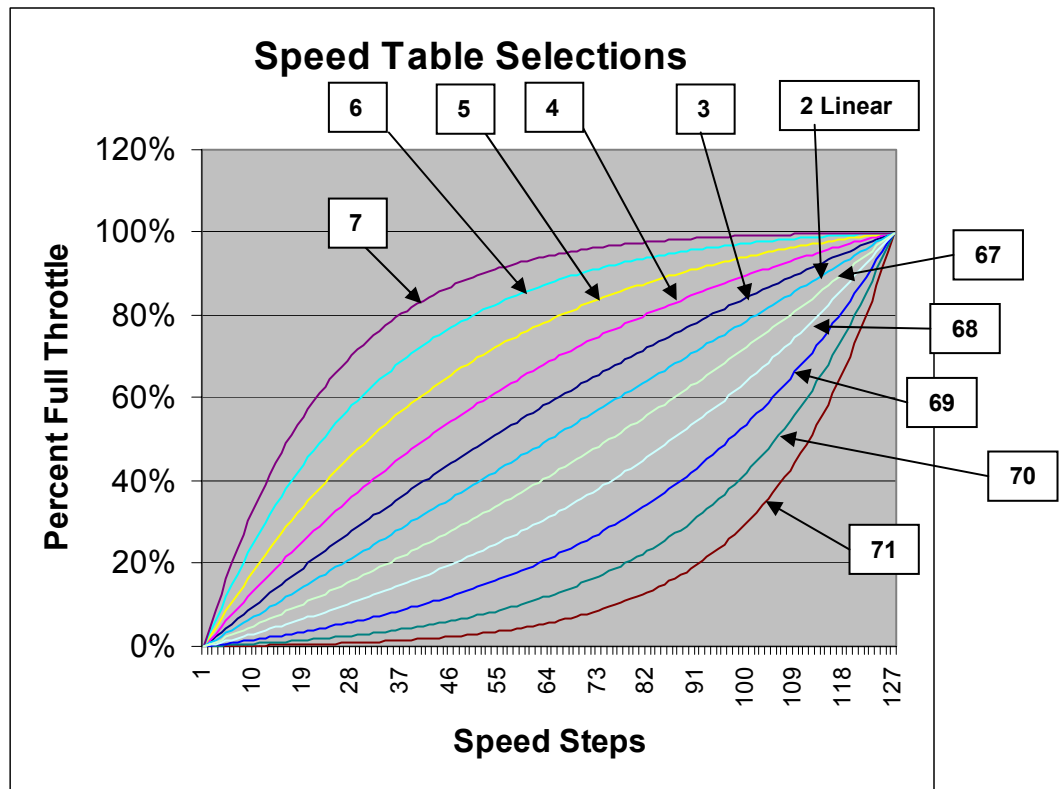

0 – QSI Standard Speed Table
 1 - User Defined
 Any other number not shown in the above graph – Linear

- To enable any speed curve shown above, set CV 25 to the value shown in the table or set it to 1 to enable a User Defined Curve (see CV 67 – 94) or set it to any other number from those shown on the graph to enable the Linear Curve.

- Bit 4 of CV 29 must be set to 1 to enable any of the above speed curves. If CV 29 bit 4 is set to “0”, then a linear straight-line response is enabled.

Additional Information for the Curious Regarding QSI Speed Curves:

- The assignment of bits to this register follows a logical sequence:

Bits 0-2: Determines how much curvature. For low values the curves are closer to linear while higher values provide greater curvature. Bits 0-2 set to 000 or 001 indicates that speed table is not used regardless of the setting in bit 6. Bits 0-2 set to 010 indicate a linear speed table.

Bit 3-5: Reserved for future QSI expansion of speed curves. Any non-zero value entered for these bits will automatically result in a Linear Response regardless of what is entered in other bits.

Bit 6: Determines if it is convex “Fast Start” or concave “Slow Start” curve.
 0 = “Fast Start” Convex Curve
 1 = “Slow Start” Concave Curve

Bit 7: This bit specifies the mid-range Speed Step and is not supported by Quantum. Set the value to 0. Either a “1” or a “0” is ignored.

The decimal value for each curve from the table below is shown on the above speed graph.

- Curve Tables in order of value for CV 25:

Value of CV 25 (Decimal)	Value of CV 25 Bits 7-0 (Binary)	Resulting Speed Table
Convex “Fast Start” Curves		
0	0 0 0 0 0 0 0 0	Reverts to User Defined Speed Table (CV 67-94)
1	0 0 0 0 0 0 0 1	Reverts to User Defined Speed Table (CV 67-94)
2	0 0 0 0 0 0 1 0	Linear Curve
3	0 0 0 0 0 0 1 1	Fast Start 1 (close to linear)
4	0 0 0 0 0 1 0 0	Fast Start 2
5	0 0 0 0 0 1 0 1	Fast Start 3
6	0 0 0 0 0 1 1 0	Fast Start 4
7	0 0 0 0 0 1 1 1	Fast Start 5 (greatest curvature)
Concave “Slow Start” Curves		
64	0 1 0 0 0 0 0 0	Reverts to Linear Curve
65	0 1 0 0 0 0 0 1	Reverts to Linear Curve
66	0 1 0 0 0 0 1 0	Linear Curve
67	0 1 0 0 0 0 1 1	Slow Start 1 (close to linear)
68	0 1 0 0 0 1 0 0	Slow Start 2
69	0 1 0 0 0 1 0 1	Slow Start 3
70	0 1 0 0 0 1 1 0	Slow Start 4
71	0 1 0 0 0 1 1 1	Slow Start 5 (greatest curvature)

- If any of the “Reverts to User Defined Table” values are set in CV 25, then the user specified speed table programmed into CV’s 67-94 will be enabled.
- Quantum Speed Tables are complete for a full 128 speed steps. They are also enabled for 14 and 28 speed steps; Quantum simply skips speed table values for the larger step sizes. However, these intermediate steps are still used under acceleration and deceleration to provide smoother operation at 14 and 28 speed steps settings.

- V-Start and V-High settings will apply to these and all curve tables as described in the sections for CV 2 and CV 5. When selecting a speed table, it is recommended that you first select your V-Start offset based on a linear curve and enter this value into CV 2, particularly for concave “slow start” curves where the V-Start point may not be obvious. Setting V-Start for a linear curve will be much more discernible; then select the type of curve you want.

3.16 CV 29 Configuration Data⁴⁰

Each bit in CV 29 controls some basic operational setting for DCC decoders.

Default Value: 00000110 = 6

CV 29: Configuration Data Register (with NMRA Assigned Features)

Accessory Decoder	Reserved for Future Use	Extended Addressing	Speed Table Enable	Advanced Decoder Acknowledgement	Power Source Conversion	FL Location	Locomotive Direction
Bit 7	Bit 6	Bit 5	Bit 4	Bit 3	Bit 2	Bit 1	Bit 0
0	N/A	D5	D4	N/A	D3	D2	D1

- Bit 0 = Locomotive Direction:

“0” = normal Forward Direction
“1” = Reversed Direction.

This bit controls the locomotives Forward and Reverse direction. With Bit 0 set to 1, the locomotive will start out in the Reverse Direction even though the Command Station indicates a Forward Direction. Directional sensitive functions, such as Headlights (FL(f) and FL(r)), will also be reversed to be consistent with the locomotives new Reverse Direction.

- Bit 1 = Speed Steps:

“0” = Bit 4 sets 14 Speed Step Mode.
“1” = Bit 4 sets 28 and 128 Speed Step Mode.

Normally in 14 Speed Step Operation, the speed and direction instruction is in one byte of transmitted data that tells the locomotive what direction to go, what speed to travel and whether the lights should be on or off. For 28-speed step operation, the bit for turning off or on the directional lights was used to increase the number of speed steps instead of lighting. When in 28-speed step mode, control of the light state must be transmitted by a separate packet, such as one of the Function Group Instructions. Setting Bit 1 in CV 29 to “1” requires that independent command be set to control the lighting such as the FL bit in Function Group 1. Similarly, to use 128 speed step mode, bit 1 of CV 29 must be set to “1” since 128-speed-step mode control byte does not contain information about the directional lighting state, so that a Function Group command needs to be sent to control lighting.

- Bit 2 = Power Source Conversion.

“0” = Power Source Conversion disabled
“1” = Power Source Conversion enabled.

If CV 29 bit 2 is “1”, and a period of approximately 200mSec⁴¹ elapses in which no DCC packet is detected, then the locomotive will convert to Analog power.

If the polarity of the track would result in the locomotive moving in the same direction that it was last moving in DCC mode, then the locomotive will continue to move at the speed corresponding to the last received speed step packet. The usual FWD/REV locomotive sound will be heard.

⁴⁰ Write bit operation is supported for CV 29.

⁴¹ NMRA Spec RP-9.2.4 specifies that Power Source Conversion should take place when DCC packets are absent for more than 30 mSec. However Quantum requires approximately 200 mSec to determine the Analog track polarity.

If the polarity of the track would result in the locomotive moving the opposite direction than it was last moving in DCC mode, then the locomotive will decelerate to a stop at a rate determined by CV 4 and CV 24, and will enter Neutral. The usual Neutral sounds will be heard.

After analog power conversion, switching the polarity of the track will either start the locomotive moving or bring it to a stop.

If the locomotive is moving and the polarity is reversed, the locomotive will decelerate to a stop at a rate determined by CV 4 and CV 24 and will enter Neutral.

If the locomotive is stopped in Neutral and the polarity is reversed, the locomotive will accelerated at a rate determined by CV 3 and CV 23 to a speed corresponding to the last received speed step packet.

The actual locomotive speed under Analog power may differ from its speed under DCC power depending on the Analog track voltage and whether the locomotive is using Speed Control, or Standard Throttle Control (e.g. the locomotive may jerk upon switching to analog power).

NOTE: This bit must be set to 1 in order for the locomotive to operate on an Analog track. See trouble shooting section.

- Bit 3 = Advanced Decoder Acknowledgement: (not used)
- Bit 4 = Speed Table set by configuration variables.

“0” Speed Table not used.

“1” Speed Table set by CV 25, Quantum Speed Table selection.

When bit 4 of CV 29 is set to “0” a linear Speed Table is used by default.

- Bit 5 = Extended Address Mode enable

“0” = Quantum responds to one byte Primary Address (see CV 1).

“1” = Quantum responds to a two byte Extended Address (see CV 17 and CV 18)

- Bit 6 = Reserved for NMRA future use.
- Bit 7 = Accessory Decoder.

“0” = Multifunction locomotive decoder.

“1” = Accessory Decoder.

Quantum is a Multifunction Decoder; this bit cannot be changed.

Command stations will either allow you to change bits directly one at a time, or you will need to enter the value of CV 29 as a complete 8-bit word (Byte) . The table below shows features designated with an “X” for CV 29 along with the Binary, Decimal, and Hex values. Choose the features you want and enter the number into CV 29 using the format recommended by your command station. The more common selections for CV 29 are shown with gray background. The default for Quantum is shown in bold type.

CV 29 Common Settings

Extended Addressing	Speed Tables	Power Conversion	28/ 128 speed step	Reversed Direction	Decimal Value	Binary Value	Hex Value
					0	00000000	0x0
				X	1	00000001	0x1
			X		2	00000010	0x2
			X	X	3	00000011	0x3
		X			4	00000100	0x4
		X		X	5	00000101	0x5
		X	X		6	00000110	0x6
		X	X	X	7	00000111	0x7
	X				16	00010000	0x10
	X			X	17	00010001	0x11
	X		X		18	00010010	0x12
	X		X	X	19	00010011	0x13
	X	X			20	00010100	0x14
	X	X		X	21	00010101	0x15
	X	X	X		22	00010110	0x16
	X	X	X	X	23	00010111	0x17
X					32	00100000	0x20
X				X	33	00100001	0x21
X			X		34	00100010	0x22
X			X	X	35	00100011	0x23
X		X			36	00100100	0x24
X		X		X	37	00100101	0x25
X		X	X		38	00100110	0x26
X		X	X	X	39	00100111	0x27
X	X				48	00110000	0x30
X	X			X	49	00110001	0x31
X	X		X		50	00110010	0x32
X	X		X	X	51	00110011	0x33
X	X	X			52	00110100	0x34
X	X	X		X	53	00110101	0x35
X	X	X	X		54	00110110	0x36
X	X	X	X	X	55	00110111	0x37

4 CV 33-46, Output Locations

4.1 Overview

The NMRA standard currently provides for fourteen Function Inputs, which are transmitted to the locomotive decoder to control the different Outputs. These fourteen Function Inputs are generally operated by thirteen⁴² Function Keys (FL, F1, F2, F3, F4, F5, F6, F7, F8, F9, F10, F11 and F12) on the command station or the hand held throttle. The FL⁴³ Function Key can produce two different Function Inputs, called FL(r) and FL(f), depending on the direction of the locomotive.

The NMRA standard provides for fourteen Outputs, numbered from 1 to 14.

CV's 33 through 46 specify which Function Input is connected to which Output.

The table below shows Output numbers across the top and Function Inputs along the side. The CV number associated with each Function Input is shown in the first column. Each of these CV's consists of an eight bit register with a "1" or "0" in each bit location, specifying which Outputs are controlled by that Function Input. The default value for each CV is shown.

CV #	Function Inputs Common Default Quantum Features Assignments	Output Numbers and Pre-assigned Features													
		Automatic Cab Lights	Number Board Lights	SMPH Report (Status Report)	Cruise Control (Shut Down)	Mute	Squealing Brakes Air Brakes (Brake Set)	Doppler Shift (Locomotive Start Up)	Dynamic Brakes	Blower Hiss/Fans	Coupler	Whistle/Horn	Bell	Directional Lighting	Directional Lighting
	Outputs	14	13	12	11	10	9	8	7	6	5	4	3	2	1
33	FL(f)							0	0	0	0	0	0	1	1
34	FL(r)							0	0	0	0	0	0	1	1
35	Function 1							0	0	0	0	0	1	0	0
36	Function 2							0	0	0	0	1	0	0	0
37	Function 3							0	0	0	1	0	0	0	0
38	Function 4				0	0	0	0	0	1	0	0			
39	Function 5				0	0	0	0	1	0	0	0			
40	Function 6				0	0	0	1	0	0	0	0			
41	Function 7				0	0	1	0	0	0	0	0			
42	Function 8				0	1	0	0	0	0	0	0			
43	Function 9	0	0	0	1	0	0	0	0						
44	Function 10	0	0	1	0	0	0	0	0						
45	Function 11	0	1	0	0	0	0	0	0						
46	Function 12	1	0	0	0	0	0	0	0						

A "1" with light gray background shows the Output default settings for Quantum. For example, CV 36 has a "1" in the column for Output 4, indicating that Function 2 controls Output 4 which will operate the Whistle or Horn.

Each Input Function can control up to 8 Outputs. The white squares in the table show allowed possible assignments of Outputs for each Function. The dark gray areas indicate where Outputs cannot be assigned. For instance, the F4 key (Function Input 4) can control only Outputs 4-11. You can chose to have the F4 Key operate Output 10 or a combination of Outputs 11, 9, 7, and 6 all at once, but you cannot have it operate Output 12.

⁴² Some earlier command stations only support the original NMRA specification of 10 functions using 9 Function Keys.

⁴³ For Command Stations that do not have an FL key, the F0 Function key usually controls this function.

For many non-sound decoders, the Outputs are literally wires that are connected to different features such as Headlights and Reverse Lights, overhead blinking lights, smoke generators, and couplers. All the Outputs are “hardwired” to the features, meaning you cannot change which feature corresponds to an Output without rewiring the features.

For Sound Decoders like the first Quantum System, only some of the Outputs were “hardwired” to a particular feature. Many of the features require no external wires. Examples of these internal features are bells, whistles, air let-offs, blower hiss, and flange sounds. Features that were hardwired to fixed outputs on early decoders included headlamps, reverse lamp, cab lamps, couplers, smoke generators, etc.

On modern decoders, even those features that do require external wires, such as lights and smoke generators, are not necessarily “hardwired” to any particular Output. Outputs are now virtual and can be connected internally by firmware in the Quantum microprocessor to any physical driver, such as a power output for a lamp or a controller for a smoke generator. The connection between a virtual output and a physical feature is called a control port or simply “port”. For consistency with NMRA definitions, virtual outputs are called simply “outputs”.

Quantum software allows us to direct “any virtual” output to any port. This has allowed us to combine some features that require two or more ports to a single virtual output. For example, our Directional Lighting, which operates a reverse lamp, forward light and sometimes a pulsing Mars Light.

Since the user no longer needs to concern himself about restrictions of which features can be assigned to which output, he has much more latitude and economy in configuring how his function keys operate different features. For instance, if it is a light or other control port, Quantum will automatically make sure that the virtual Output is connected to the correct port to control that feature. This extra freedom means you could connect some feature to operate in Forward with the FL(f) key and some other feature to operate only in Reverse with the FL(r) key and not lose the Directional Lighting feature which would be assigned to some other Output. As an example, you could assign FL(f) to Cruise Control (since Cruise Control is less needed as a desirable control in Reverse) and FL(r) to Coupler Operation since this is where the Quantum Coupler crash sound is likely more appropriate. And then assign the Directional Lighting System to the Output 5, which was previously assigned to Coupler Sounds. You have now freed up Output 11, which was formally used for Cruise Control, to operate another feature.

Quantum also allows outputs to be redirected to different features depending on the directional state of the locomotive. For example, Output 8 might be assigned to Doppler Shift in Forward and Reverse but be assigned to “Locomotive Start Up” in Neutral. Mapping an output to two different features, one feature for the Forward/Reverse State (Motive State) and a different feature for the Neutral State, increases the number of features that can be operated. For QSI Quantum Sound Decoders, features are assigned to outputs in CV 53.

The above table shows Common Default Quantum Features Assignments in the second row. Features assignments that operate only in Neutral are shown in parenthesis under the feature that operates in Forward and Reverse. If no Neutral feature is shown, the assigned feature shown will operate in all directional states.

Advanced Sound Decoders like the Quantum Decoders allow great flexibility in choosing which function keys operate which features. However, this flexibility can get you into trouble if misused. For technical reasons too complicated to discuss here⁴⁴, we recommend you follow the two rules below to avoid having your decoder behave in a confusing manner.

- In CV’s 33-46, do not attempt to control the same Output with two or more function keys. This means, in the table above, only one row in each column should have a “1”. Yes, we violated this rule for Output 1 and Output 2, where we have both FL(f) and FL(r) operating the Directional Lighting System. This is an exception, which does work for Directional Lighting using FL(f) and FL(r). In general, it is not a good idea.
- In CV 53, do not assign the same feature to two or more Outputs.

Note: The following CV’s for output assignments also show default features and the affect of sending a “1” or “0” function command for Level Activated (LA) features or sending a change in the function such as “1-0” or “0-1” for Transition Activated (TA) features, or sending a double command such as “1-0-1” or “0-1-0” for Pulse Activated (PA) features. See Appendix V and Appendix V1 for a complete description of LA, TA and PA features.

⁴⁴ See Appendix VI Interaction of Function Keys, Function Groups, Function Inputs and Outputs and Feature Assignments for additional technical explanation.

4.2 CV 33 Output Location for FL(f)⁴⁵

This CV specifies whether outputs 1 thru 8 are controlled by FL(f) .

A '1' in a bit location specifies the output is controlled by FL(f), while a '0' specifies the output is not controlled by FL(f).

Default Value: 0000011 = 3

CV 33: Output Location for FL(f) (with Factory Default Features)

Doppler (Start Up)	Dynamic Brakes	Blower-Hiss/Fans	Coupler Crash Coupler Fire (Coupler Arm)	Whistle/Horn	Bell	Directional Lighting	Directional Lighting
Bit 7	Bit 6	Bit 5	Bit 4	Bit 3	Bit 2	Bit 1	Bit 0
Output 8	Output 7	Output 6	Output 5	Output 4	Output 3	Output 2	Output 1

- QSI has pre-assigned default features to each output but any feature can be assigned to any output in CV 53. In CV 53, the default setting for Outputs 1 and 2 is the Directional Lighting System. Therefore, by default FL(f) controls the Directional Lighting System in Forward or Neutral from Forward.
- You can specify that FL(f) control any of Outputs 2 thru 8 in addition to or instead of Outputs 1 and 2.
- Assuming the default CV 53 settings (shown in the top row)⁴⁶, you can specify that FL(f) control the following features.

Bit 0 Output 1: Directional Lighting

- “0” The Directional Lighting System is unaffected by FL(f).
- “1” The Directional Lighting System is affected by FL(f).

Bit 1 Output 2: Directional Reverse Light

- “0” The Directional Lighting System is unaffected by FL(f).
- “1” The Directional Lighting System is affected by FL(f).

Bit 2 Output 3; Bell

- “0” The Bell is unaffected by FL(f).
- “1” The Bell is affected by FL(f).

Bit 3 Output 4; Whistle/Horn

- “0” The Whistle/Horn is unaffected by FL(f).
- “1” Whistle/Horn is affected by FL(f).

Bit 4 Output 5: Coupler Crash, Coupler Arm, Coupler Fire.

- “0” The Coupler Sounds are unaffected by FL(f).
- “1” The Coupler Sounds are affected by FL(f).

⁴⁵ Write bit operation is supported for CV 33.

⁴⁶ Features that are different in the Neutral state are shown in parentheses

Bit 5 Output 6: Steam Locomotive Blower Hiss or Diesel or Electric Loco Vents and Fans

- "0" Blower-Hiss/Fans are unaffected by FL(f).
- "1" Blower-Hiss/Fans are affected by FL(f).

Bit 6 Output 7: Dynamic Brakes

- "0" Dynamic Brakes are unaffected by FL(f).
- "1" Dynamic Brakes are affected by FL(f).

Bit 7 Output 8: Doppler, Start Up

- "0" Doppler shift in Forward/Reverse and Start up in Neutral are unaffected by FL(f).
- "1" Doppler shift in Forward/Reverse and Start up in Neutral are affected by FL(f).

4.3 CV 34 Output Location for FL(r)⁴⁷

This CV specifies whether outputs 1 thru 8 are controlled by FL(r).

A '1' in a bit location specifies the output is controlled by FL(r), while a '0' specifies the output is not controlled by FL(r).

Default Value: 0000011 = 3

CV 34: Output Location for FL(r) (with Factory Default Features)

Doppler (Start Up)	Dynamic Brakes	Blower-Hiss/Fans	Coupler Crash Coupler Fire (Coupler Arm)	Whistle/Horn	Bell	Directional Lighting	Directional Lighting
Bit 7	Bit 6	Bit 5	Bit 4	Bit 3	Bit 2	Bit 1	Bit 0
Output 8	Output 7	Output 6	Output 5	Output 4	Output 3	Output 2	Output 1

- QSI has pre-assigned default features to each output but any feature can be assigned to any output in CV 53. In CV 53, the default setting for Outputs 1 and 2 is the Directional Lighting System. Therefore, by default FL(r) controls the Directional Lighting System in Reverse or Neutral from Reverse.
- You can specify that FL(r) control any of Outputs 3 thru 8 in addition to or instead of Outputs 1 and 2.
- Assuming the default CV 53 settings (shown in the top row)⁴⁸, you can specify that FL(r) control the following features.

Bit 0 Output 1: Directional Lighting

- “0” The Directional Lighting System is unaffected by FL(r).
- “1” The Directional Lighting System is affected by FL(r).

Bit 1 Output 2: Directional Reverse Light

- “0” The Directional Lighting System is unaffected by FL(r).
- “1” The Directional Lighting System is affected by FL(r).

Bit 2 Output 3; Bell

- “0” The Bell is unaffected by FL(r).
- “1” The Bell is affected by FL(r).

Bit 3 Output 4; Whistle/Horn

- “0” The Whistle/Horn is unaffected by FL(r).
- “1” Whistle/Horn is affected by FL(r).

Bit 4 Output 5: Coupler Crash, Coupler Arm, Coupler Fire.

- “0” The Coupler Sounds are unaffected by FL(r).
- “1” The Coupler Sounds are affected by FL(r).

⁴⁷ Write bit operation is supported for CV 34.

⁴⁸ Features that are different in the Neutral state are shown in parentheses

Bit 5 Output 6: Steam Locomotive Blower Hiss or Diesel or Electric Loco Vents and Fans

“0” Blower-Hiss/Fans are unaffected by FL(r).
“1” Blower-Hiss/Fans are affected by FL(r).

Bit 6 Output 7: Dynamic Brakes

“0” Dynamic Brakes are unaffected by FL(r).
“1” Dynamic Brakes are affected by FL(r).

Bit 7 Output 8: Doppler, Start Up

“0” Doppler shift in Forward/Reverse and Start up in Neutral are unaffected by FL(r).
“1” Doppler shift in Forward/Reverse and Start up in Neutral are affected by FL(r).

4.4 CV 35 Output Location for F1⁴⁹

This CV specifies whether outputs 1 thru 8 are controlled by F1.

A '1' in a bit location specifies the output is controlled by F1, while a '0' specifies the output is not controlled by F1.

Default Value: 00000100 = 4

CV 35: Output for F1 (with Factory Default Features)

Doppler (Start Up)	Dynamic Brakes	Blower-Hiss/Fans	Coupler Crash Coupler Fire (Coupler Arm)	Whistle/Horn	Bell	Directional Lighting	Directional Lighting
Bit 7	Bit 6	Bit 5	Bit 4	Bit 3	Bit 2	Bit 1	Bit 0
Output 8	Output 7	Output 6	Output 5	Output 4	Output 3	Output 2	Output 1

- QSI has pre-assigned default features to each output but any feature can be assigned to any output in CV 53. In CV 53, the default setting for Output 3 is the Bell. Therefore, by default F1 controls the Bell.
- You can specify that F1 control any of Outputs 1-2 and 4-8 in addition to or instead of Output 3.
- Assuming the default CV 53 settings (shown in the top row)⁵⁰, you can specify that F1 control the following features.

Bit 0 Output 1: Directional Lighting

- “0” The Directional Lighting System is unaffected by F1.
- “1” The Directional Lighting System is affected by F1.

Bit 1 Output 2: Directional Reverse Light

- “0” The Directional Lighting System is unaffected by F1.
- “1” The Directional Lighting System is affected by F1.

Bit 2 Output 3; Bell

- “0” The Bell is unaffected by F1.
- “1” The Bell is affected by F1.

Bit 3 Output 4; Whistle/Horn

- “0” The Whistle/Horn is unaffected by F1.
- “1” Whistle/Horn is affected by F1.

Bit 4 Output 5: Coupler Crash, Coupler Arm, Coupler Fire.

- “0” The Coupler Sounds are unaffected by F1.
- “1” The Coupler Sounds are affected by F1.

⁴⁹ Write bit operation is supported for CV 35.

⁵⁰ Features that are different in the Neutral state are shown in parentheses

Bit 5 Output 6: Steam Locomotive Blower Hiss or Diesel or Electric Loco Vents and Fans

“0” Blower-Hiss/Fans are unaffected by F1.
“1” Blower-Hiss/Fans are affected by F1.

Bit 6 Output 7: Dynamic Brakes

“0” Dynamic Brakes are unaffected by F1.
“1” Dynamic Brakes are affected by F1.

Bit 7 Output 8: Doppler, Start Up

“0” Doppler shift in Forward/Reverse and Start up in Neutral are unaffected by F1.
“1” Doppler shift in Forward/Reverse and Start up in Neutral are affected by F1.

4.5 CV 36 Output Location for F2⁵¹

This CV specifies whether outputs 1 thru 8 are controlled by F2.

A '1' in a bit location specifies the output is controlled by F2, while a '0' specifies the output is not controlled by F2.

Default Value: 00001000 = 8

CV 36: Output Location for F2 (with Factory Default Features)

Doppler (Start Up)	Dynamic Brakes	Blower-Hiss/Fans	Coupler Crash Coupler Fire (Coupler Arm)	Whistle/Horn	Bell	Directional Lighting	Directional Lighting
Bit 7	Bit 6	Bit 5	Bit 4	Bit 3	Bit 2	Bit 1	Bit 0
Output 8	Output 7	Output 6	Output 5	Output 4	Output 3	Output 2	Output 1

- QSI has pre-assigned default features to each output but any feature can be assigned to any output in CV 53. In CV 53, the default setting for Output 4 is the Whistle or Horn. Therefore, by default F2 controls the Whistle or Horn while locomotive is moving or stopped.
- You can specify that F1 control any of Outputs 1-3 and 5-8 in addition to or instead of Output 4.
- Assuming the default CV 53 settings (shown in the top row)⁵², you can specify that F2 control the following features.

Bit 0 Output 1: Directional Lighting

- “0” The Directional Lighting System is unaffected by F2.
- “1” The Directional Lighting System is affected by F2.

Bit 1 Output 2: Directional Reverse Light

- “0” The Directional Lighting System is unaffected by F2.
- “1” The Directional Lighting System is affected by F2.

Bit 2 Output 3; Bell

- “0” The Bell is unaffected by F2.
- “1” The Bell is affected by F2.

Bit 3 Output 4; Whistle/Horn

- “0” The Whistle/Horn is unaffected by F2.
- “1” Whistle/Horn is affected by F2.

Bit 4 Output 5: Coupler Crash, Coupler Arm, Coupler Fire.

- “0” The Coupler Sounds are unaffected by F2.
- “1” The Coupler Sounds are affected by F2.

⁵¹ Write bit operation is supported for CV 36.

⁵² Features that are different in the Neutral state are shown in parentheses

Bit 5 Output 6: Steam Locomotive Blower Hiss or Diesel or Electric Loco Vents and Fans

“0” Blower-Hiss/Fans are unaffected by F2.
“1” Blower-Hiss/Fans are affected by F2.

Bit 6 Output 7: Dynamic Brakes

“0” Dynamic Brakes are unaffected by F2.
“1” Dynamic Brakes are affected by F2.

Bit 7 Output 8: Doppler, Start Up

“0” Doppler shift in Forward/Reverse and Start up in Neutral are unaffected by F2.
“1” Doppler shift in Forward/Reverse and Start up in Neutral are affected by F2.

4.6 CV 37 Output Location for F3⁵³

This CV specifies whether outputs 1 thru 8 are controlled by F3.

A '1' in a bit location specifies the output is controlled by F3, while a '0' specifies the output is not controlled by F3.

Default Value: 00010000 = 16

CV 37: Output Location for F3 (with Factory Default Features)

Doppler (Start Up)	Dynamic Brakes	Blower-Hiss/Fans	Coupler Crash Coupler Fire (Coupler Arm)	Whistle/Horn	Bell	Directional Lighting	Directional Lighting
Bit 7	Bit 6	Bit 5	Bit 4	Bit 3	Bit 2	Bit 1	Bit 0
Output 8	Output 7	Output 6	Output 5	Output 4	Output 3	Output 2	Output 1

- QSI has pre-assigned default features to each output but any feature can be assigned to any output in CV 53. In CV 53, the default setting for Output 5 is the Coupler Crash, Coupler Fire and Coupler Arm. Therefore, by default F3 controls the Coupler Sounds.
- You can specify that F3 control any of Outputs 1-4 and 6-8 in addition to or instead of Output 5.
- Assuming the default CV 53 settings (shown in the top row)⁵⁴, you can specify that F3 control the following features.

Bit 0 Output 1: Directional Lighting

- “0” The Directional Lighting System is unaffected by F3.
- “1” The Directional Lighting System is affected by F3.

Bit 1 Output 2: Directional Reverse Light

- “0” The Directional Lighting System is unaffected by F3.
- “1” The Directional Lighting System is affected by F3.

Bit 2 Output 3; Bell

- “0” The Bell is unaffected by F3.
- “1” The Bell is affected by F3.

Bit 3 Output 4; Whistle/Horn

- “0” The Whistle/Horn is unaffected by F3.
- “1” Whistle/Horn is affected by F3.

Bit 4 Output 5: Coupler Crash, Coupler Arm, Coupler Fire.

- “0” The Coupler Sounds are unaffected by F3.
- “1” The Coupler Sounds are affected by F3.

⁵³ Write bit operation is supported for CV 37.

⁵⁴ Features that are different in the Neutral state are shown in parentheses

Bit 5 Output 6: Steam Locomotive Blower Hiss or Diesel or Electric Loco Vents and Fans

- "0" Blower-Hiss/Fans are unaffected by F3.
- "1" Blower-Hiss/Fans are affected by F3.

Bit 6 Output 7: Dynamic Brakes

- "0" Dynamic Brakes are unaffected by F3.
- "1" Dynamic Brakes are affected by F3.

Bit 7 Output 8: Doppler, Start Up

- "0" Doppler shift in Forward/Reverse and Start up in Neutral are unaffected by F3.
- "1" Doppler shift in Forward/Reverse and Start up in Neutral are affected by F3.

Example: Change F3 to Bell Operation (Output 3), and change F1 to Output 5 (Coupler Sounds). The Bell is permanently set to Output 3. Output 5 is set by QSI to the Coupler Sound Feature by default.

1. Set CV 37 (F3) to "4" (bit 2 = output 3 = Bell)
2. Set CV 35 (F1) to "16" (bit 4 = output 5 = Coupler Sounds)

After these changes, F3 will toggle the bell, and F1 will activate Coupler Sounds.

4.7 CV 38 Output Location for F4⁵⁵

This CV specifies whether outputs 4 thru 11 are controlled by F4.

A '1' in a bit location specifies the output is controlled by F4, while a '0' specifies the output is not controlled by F4.

Default Value: 00000100 = 4

CV 38: Output Location for F4 Register (with Factory Default Features)

Cruise Control (Disconnect- Standby-Shut Down)	Mute	Squealing Brakes – Air Brakes (Brake Set)	Doppler (Start Up)	Dynamic Brakes	Blower- Hiss/Fans	Coupler Crash Coupler Fire (Coupler Arm)	Whistle/Horn
Bit 7	Bit 6	Bit 5	Bit 4	Bit 3	Bit 2	Bit 1	Bit 0
Output 11	Output 10	Output 9	Output 8	Output 7	Output 6	Output 5	Output 4

- QSI has pre-assigned default features to each output but any feature can be assigned to any output in CV 53. In CV 53, the default setting for Output 6 is Blower Hiss/Fans. Therefore, by default F4 controls the Blower Hiss/Fans Sound.
- You can specify that F4 control any of Outputs 4-5 and 7-11 in addition to or instead of Output 6.
- Assuming the default CV 53 settings (shown in the top row)⁵⁶, you can specify that F4 control the following features.

Bit 0 Output 4; Whistle/Horn

"0" The Whistle/Horn is unaffected by F4.
 "1" Whistle/Horn is affected by F4.

Bit 1 Output 5: Coupler Crash, Coupler Arm, Coupler Fire.

"0" The Coupler Sounds are unaffected by F4.
 "1" The Coupler Sounds are affected by F4.

Bit 2 Output 6: Steam Locomotive Blower Hiss or Diesel or Electric Loco Vents and Fans

"0" Blower-Hiss/Fans are unaffected by F4.
 "1" Blower-Hiss/Fans are affected by F4.

Bit 3 Output 7: Dynamic Brakes

"0" Dynamic Brakes are unaffected by F4.
 "1" Dynamic Brakes are affected by F4.

⁵⁵ Write bit operation is supported for CV 38.

⁵⁶ Features that are different in the Neutral state are shown in parentheses

Bit 4 Output 8: Doppler, Start Up

- “0” Doppler shift in Forward/Reverse and Start up in Neutral are unaffected by F4.
- “1” Doppler shift in Forward/Reverse and Start up in Neutral are affected by F4.

Bit 5 Output 9: Squealing Brakes and Air Brakes, Long Air Let-off or Special Feature

- “0” Squealing Brakes, Air Brakes in Forward/Reverse and Long Air Let-off are unaffected by F4.
- “1” Squealing Brakes, Air Brakes in Forward/Reverse and Long Air Let-off are affected by F4.

Bit 6 Output 10: Audio Mute or

- “0” Audio Mute is unaffected by F4.
- “1” Audio Mute is affected by F4.

Bit 7 Output 11: Cruise Control, Disconnect-Standby-Total Shut Down

- “0” Cruise Control in Forward/Reverse and Disconnect-Standby-Total Shut Down in Neutral are unaffected by F4.
- “1” Cruise Control in Forward/Reverse and Disconnect-Standby-Total Shut Down in Neutral are affected by F4.

Note: Cruise Control was only available on Lionel HO and early BLI locomotives.

4.8 CV 39 Output Location for F5⁵⁷

This CV specifies whether outputs 4 thru 11 are controlled by F5.

A '1' in a bit location specifies the output is controlled by F5, while a '0' specifies the output is not controlled by F5.

Default Value: 00001000 = 8

CV 39: Output Location for F5 Register (with Factory Default Features)

Cruise Control (Disconnect- Standby-Total Shut Down)	Mute	Squealing Brakes – Air Brakes (Brake Set)	Doppler (Start Up)	Dynamic Brakes	Blower- Hiss/Fans	Coupler Crash Coupler Fire (Coupler Arm)	Whistle/Horn
Bit 7	Bit 6	Bit 5	Bit 4	Bit 3	Bit 2	Bit 1	Bit 0
Output 11	Output 10	Output 9	Output 8	Output 7	Output 6	Output 5	Output 4

- QSI has pre-assigned default features to each output but any feature can be assigned to any output in CV 53. In CV 53, the default setting for Output 7 is Dynamic Brakes. Therefore, by default F5 controls the Dynamic Brake Sounds.
- You can specify that F5 control any of Outputs 4-6 and 8-11 in addition to or instead of Output 7.
- Assuming the default CV 53 settings (shown in the top row)⁵⁸, you can specify that F5 control the following features.

Bit 0 Output 4; Whistle/Horn

"0" The Whistle/Horn is unaffected by F5.
 "1" Whistle/Horn is affected by F5.

Bit 1 Output 5: Coupler Crash, Coupler Arm, Coupler Fire.

"0" The Coupler Sounds are unaffected by F5.
 "1" The Coupler Sounds are affected by F5.

Bit 2 Output 6: Steam Locomotive Blower Hiss or Diesel or Electric Loco Vents and Fans

"0" Blower-Hiss/Fans are unaffected by F5.
 "1" Blower-Hiss/Fans are affected by F5.

Bit 3 Output 7: Dynamic Brakes

"0" Dynamic Brakes are unaffected by F5.
 "1" Dynamic Brakes are affected by F5.

⁵⁷ Write bit operation is supported for CV 39.

⁵⁸ Features that are different in the Neutral state are shown in parentheses

Bit 4 Output 8: Doppler, Start Up

- "0" Doppler shift in Forward/Reverse and Start up in Neutral are unaffected by F5.
- "1" Doppler shift in Forward/Reverse and Start up in Neutral are affected by F5.

Bit 5 Output 9: Squealing Brakes and Air Brakes, Long Air Let-off or Special Feature

- "0" Squealing Brakes, Air Brakes in Forward/Reverse and Long Air Let-off are unaffected by F5.
- "1" Squealing Brakes, Air Brakes in Forward/Reverse and Long Air Let-off are affected by F5.

Bit 6 Output 10: Audio Mute or

- "0" Audio Mute is unaffected by F5.
- "1" Audio Mute is affected by F5.

Bit 7 Output 11: Cruise Control, Disconnect-Standby-Total Shut Down

- "0" Cruise Control in Forward/Reverse and Disconnect-Standby-Total Shut Down in Neutral are unaffected by F5.
- "1" Cruise Control in Forward/Reverse and Disconnect-Standby-Total Shut Down in Neutral are affected by F5.

Note: Cruise Control was only available on Lionel HO and early BLI locomotives.

4.9 CV 40 Output Location for F6⁵⁹

This CV specifies whether outputs 4 thru 11 are controlled by F6.

A '1' in a bit location specifies the output is controlled by F6, while a '0' specifies the output is not controlled by F6.

Default Value:

00010000 = 16

CV 40: F6 Output Location for F6 Register (with Factory Default Features)

Cruise Control (Disconnect- Standby-Total Shut Down)	Mute	Squealing Brakes – Air Brakes (Brake Set)	Doppler (Start Up)	Dynamic Brakes	Blower- Hiss/Fans	Coupler Crash Coupler Fire (Coupler Arm)	Whistle/Horn
Bit 7	Bit 6	Bit 5	Bit 4	Bit 3	Bit 2	Bit 1	Bit 0
Output 11	Output 10	Output 9	Output 8	Output 7	Output 6	Output 5	Output 4

- QSI has pre-assigned default features to each output but any feature can be assigned to any output in CV 53. In CV 53, the default settings for Output 8 are Doppler Shift for a moving locomotive and Locomotive Start Up in Neutral. Therefore, by default F6 controls Doppler Shift and Start Up.
- You can specify that F6 control any of Outputs 4-7 and 9-11 in addition to or instead of Output 8.
- Assuming the default CV 53 settings (shown in the top row)⁶⁰, you can specify that F6 control the following features.

Bit 0 Output 4; Whistle/Horn

"0" The Whistle/Horn is unaffected by F6.
 "1" Whistle/Horn is affected by F6.

Bit 1 Output 5: Coupler Crash, Coupler Arm, Coupler Fire.

"0" The Coupler Sounds are unaffected by F6.
 "1" The Coupler Sounds are affected by F6.

Bit 2 Output 6: Steam Locomotive Blower Hiss or Diesel or Electric Loco Vents and Fans

"0" Blower-Hiss/Fans are unaffected by F6.
 "1" Blower-Hiss/Fans are affected by F6.

Bit 3 Output 7: Dynamic Brakes

"0" Dynamic Brakes are unaffected by F6.
 "1" Dynamic Brakes are affected by F6.

⁵⁹ Write bit operation is supported for CV 40.

⁶⁰ Features that are different in the Neutral state are shown in parentheses

Bit 4 Output 8: Doppler, Start Up

- “0” Doppler shift in Forward/Reverse and Start up in Neutral are unaffected by F6.
- “1” Doppler shift in Forward/Reverse and Start up in Neutral are affected by F6.

Bit 5 Output 9: Squealing Brakes and Air Brakes, Long Air Let-off or Special Feature

- “0” Squealing Brakes, Air Brakes in Forward/Reverse and Long Air Let-off are unaffected by F6.
- “1” Squealing Brakes, Air Brakes in Forward/Reverse and Long Air Let-off are affected by F6.

Bit 6 Output 10: Audio Mute or

- “0” Audio Mute is unaffected by F6.
- “1” Audio Mute is affected by F6.

Bit 7 Output 11: Cruise Control, Disconnect-Standby-Total Shut Down

- “0” Cruise Control in Forward/Reverse and Disconnect-Standby-Total Shut Down in Neutral are unaffected by F6.
- “1” Cruise Control in Forward/Reverse and Disconnect-Standby-Total Shut Down in Neutral are affected by F6.

Note: Cruise Control was only available on Lionel HO and early BLI locomotives.

4.10 CV 41 Output Location for F7⁶¹

This CV specifies whether outputs 4 thru 11 are controlled by F7.

A '1' in a bit location specifies the output is controlled by F7, while a '0' specifies the output is not controlled by F7.

Default Value:

00100000 = 32

CV 41: Output Location for F7 Register (with Factory Default Features)

Cruise Control (Disconnect-Standby-Total Shut Down)	Mute	Squealing Brakes – Air Brakes (Brake Set)	Doppler (Start Up)	Dynamic Brakes	Blower-Hiss/Fans	Coupler Crash Coupler Fire (Coupler Arm)	Whistle/Horn
Bit 7	Bit 6	Bit 5	Bit 4	Bit 3	Bit 2	Bit 1	Bit 0
Output 11	Output 10	Output 9	Output 8	Output 7	Output 6	Output 5	Output 4

- QSI has pre-assigned default features to each output but any feature can be assigned to any output in CV 53. In CV 53, the default settings for Output 9 are Squealing Brakes plus Air Brakes for a moving locomotive and a Long Air Let-off for a Brake Set in Neutral. Therefore, by default F7 controls Squealing Brakes or Air Brakes for a moving locomotive and a Brake Set Sound in Neutral.
- You can specify that F7 control any of Outputs 4-8 and 10-11 in addition to or instead of Output 9.
- Assuming the default CV 53 settings (shown in the top row)⁶², you can specify that F7 control the following features.

Bit 0 Output 4; Whistle/Horn

“0” The Whistle/Horn is unaffected by F7.
 “1” Whistle/Horn is affected by F7.

Bit 1 Output 5: Coupler Crash, Coupler Arm, Coupler Fire.

“0” The Coupler Sounds are unaffected by F7.
 “1” The Coupler Sounds are affected by F7.

Bit 2 Output 6: Steam Locomotive Blower Hiss or Diesel or Electric Loco Vents and Fans

“0” Blower-Hiss/Fans are unaffected by F7.
 “1” Blower-Hiss/Fans are affected by F7.

Bit 3 Output 7: Dynamic Brakes

“0” Dynamic Brakes are unaffected by F7.
 “1” Dynamic Brakes are affected by F7.

⁶¹ Write bit operation is supported for CV 41.

⁶² Features that are different in the Neutral state are shown in parentheses

Bit 4 Output 8: Doppler, Start Up

- “0” Doppler shift in Forward/Reverse and Start up in Neutral are unaffected by F7.
- “1” Doppler shift in Forward/Reverse and Start up in Neutral are affected by F7.

Bit 5 Output 9: Squealing Brakes and Air Brakes, Long Air Let-off or Special Feature

- “0” Squealing Brakes, Air Brakes in Forward/Reverse and Long Air Let-off are unaffected by F7.
- “1” Squealing Brakes, Air Brakes in Forward/Reverse and Long Air Let-off are affected by F7.

Bit 6 Output 10: Audio Mute or

- “0” Audio Mute is unaffected by F7.
- “1” Audio Mute is affected by F7.

Bit 7 Output 11: Cruise Control, Disconnect-Standby-Total Shut Down

- “0” Cruise Control in Forward/Reverse and Disconnect-Standby-Total Shut Down in Neutral are unaffected by F7.
- “1” Cruise Control in Forward/Reverse and Disconnect-Standby-Total Shut Down in Neutral are affected by F7.

Note: Cruise Control was only available on Lionel HO and early BLI locomotives.

4.11 CV 42 Output Location for F8⁶³

This CV specifies whether outputs 4 thru 11 are controlled by F8.

A '1' in a bit location specifies the output is controlled by F8, while a '0' specifies the output is not controlled by F8.

Default Value: 01000000 = 64

CV 42: Output Location for F8 Register (with Factory Default Features)

Cruise Control (Disconnect- Standby-Total Shut Down)	Mute	Squealing Brakes – Air Brakes (Brake Set)	Doppler (Start Up)	Dynamic Brakes	Blower- Hiss/Fans	Coupler Crash Coupler Fire (Coupler Arm)	Whistle/Horn
Bit 7	Bit 6	Bit 5	Bit 4	Bit 3	Bit 2	Bit 1	Bit 0
Output 11	Output 10	Output 9	Output 8	Output 7	Output 6	Output 5	Output 4

- QSI has pre-assigned default features to each output but any feature can be assigned to any output in CV 53. In CV 53, the default setting for Output 10 is Audio Mute. Therefore, by default F8 controls Audio Mute.
- You can specify that F8 control any of Outputs 4-9 and 11 in addition to or instead of Output 10.
- Assuming the default CV 53 settings (shown in the top row)⁶⁴, you can specify that F8 control the following features.

Bit 0 Output 4; Whistle/Horn

“0” The Whistle/Horn is unaffected by F8.
 “1” Whistle/Horn is affected by F8.

Bit 1 Output 5: Coupler Crash, Coupler Arm, Coupler Fire.

“0” The Coupler Sounds are unaffected by F8.
 “1” The Coupler Sounds are affected by F8.

Bit 2 Output 6: Steam Locomotive Blower Hiss or Diesel or Electric Loco Vents and Fans

“0” Blower-Hiss/Fans are unaffected by F8.
 “1” Blower-Hiss/Fans are affected by F8.

Bit 3 Output 7: Dynamic Brakes

“0” Dynamic Brakes are unaffected by F8.
 “1” Dynamic Brakes are affected by F8.

⁶³ Write bit operation is supported for CV 42.

⁶⁴ Features that are different in the Neutral state are shown in parentheses

Bit 4 Output 8: Doppler, Start Up

- "0" Doppler shift in Forward/Reverse and Start up in Neutral are unaffected by F8.
- "1" Doppler shift in Forward/Reverse and Start up in Neutral are affected by F8.

Bit 5 Output 9: Squealing Brakes and Air Brakes, Long Air Let-off or Special Feature

- "0" Squealing Brakes, Air Brakes in Forward/Reverse and Long Air Let-off are unaffected by F8.
- "1" Squealing Brakes, Air Brakes in Forward/Reverse and Long Air Let-off are affected by F8.

Bit 6 Output 10: Audio Mute or

- "0" Audio Mute is unaffected by F8.
- "1" Audio Mute is affected by F8.

Bit 7 Output 11: Cruise Control, Disconnect-Standby-Total Shut Down

- "0" Cruise Control in Forward/Reverse and Disconnect-Standby-Total Shut Down in Neutral are unaffected by F8.
- "1" Cruise Control in Forward/Reverse and Disconnect-Standby-Total Shut Down in Neutral are affected by F8.

Note: Cruise Control was only available on Lionel HO and early BLI locomotives.

4.12 CV 43 Output Location for F9⁶⁵

This CV specifies whether outputs 7 thru 14 are controlled by F9.

A '1' in a bit location specifies the output is controlled by F9, while a '0' specifies the output is not controlled by F9.

Default Value: 00010000 = 16

CV 43: Output Location for F9 Register (with Factory Default Features)

Cab Lights	Number Board Lights	SMPH Report (Status Report)	Cruise Control (Disconnect-Standby-Total Shut Down)	Mute	Squealing Brakes – Air Brakes (Brake Set)	Doppler (Start Up)	Dynamic Brakes
Bit 7	Bit 6	Bit 5	Bit 4	Bit 3	Bit 2	Bit 1	Bit 0
Output 14	Output 13	Output 12	Output 11	Output 10	Output 9	Output 8	Output 7

- QSI has pre-assigned default features to each output but any feature can be assigned to any output in CV 53. In CV 53, the default settings for Output 11 are Cruise Control for a moving locomotive and Disconnect-Standby-Shut Down for a locomotive in Neutral. Therefore, by default F9 controls Cruise Control and Disconnect-Standby-Shut Down.

Note: Cruise Control was only available on Lionel HO and early BLI locomotives.

- You can specify that F9 control any of Outputs 7-10 and 12-14 in addition to or instead of Output 11.
- Assuming the default CV 53 settings (shown in the top row)⁶⁶, you can specify that F9 control the following features.

Bit 0 Output 7: Dynamic Brakes

"0" Dynamic Brakes are unaffected by F9.
 "1" Dynamic Brakes are affected by F9.

Bit 1 Output 8: Doppler, Start Up

"0" Doppler shift in Forward/Reverse and Start up in Neutral are unaffected by F9.
 "1" Doppler shift in Forward/Reverse and Start up in Neutral are affected by F9.

Bit 2 Output 9: Squealing Brakes and Air Brakes, Long Air Let-off or Special Feature

"0" Squealing Brakes, Air Brakes in Forward/Reverse and Long Air Let-off are unaffected by F9.
 "1" Squealing Brakes, Air Brakes in Forward/Reverse and Long Air Let-off are affected by F9.

Bit 3 Output 10: Audio Mute

"0" Audio Mute is unaffected by F9.
 "1" Audio Mute is affected by F9.

⁶⁵ Write bit operation is supported for CV 43.

⁶⁶ Features that are different in the Neutral state are shown in parentheses

⁶⁸ Write bit operation is supported for CV 44.

Bit 4 Output 11: Cruise Control, Disconnect-Standby-Total Shut Down

“0” Cruise Control in Forward/Reverse and Disconnect-Standby-Total Shut Down in Neutral are unaffected by F9.

“1” Cruise Control in Forward/Reverse and Disconnect-Standby-Total Shut Down in Neutral are affected by F9.

Note: Cruise Control was only available on Lionel HO and early BLI locomotives.

Bit 5 Output 12: Speed Report, Status Report

“0” Speed Report in Forward/Reverse and Status Report in Neutral are unaffected by F9.

“1” Speed Report in Forward/Reverse and Status Report in Neutral are unaffected by F9.

Bit 6 Output 13: Number Board Lights

“0” Number Board Lights are unaffected by F9.

“1” Number Board Lights are affected by F9.

Bit 7 Output 14: Cab Lights

“0” Cab Lights are unaffected by F9.

“1” Cab Lights are affected by F9.

4.13 CV 44 Output Location for F10⁶⁸

This CV specifies whether outputs 7 thru 14 are controlled by F10.

A '1' in a bit location specifies the output is controlled by F10, while a '0' specifies the output is not controlled by F10.

Default Value:

00100000 = 32

CV 44: Output Location for F10 Register (with Factory Default Features)

Cab Lights	Number Board Lights	SMPH Report (Status Report)	Cruise Control (Disconnect-Standby-Total Shut Down)	Mute	Squealing Brakes – Air Brakes (Brake Set)	Doppler (Start Up)	Dynamic Brakes
Bit 7	Bit 6	Bit 5	Bit 4	Bit 3	Bit 2	Bit 1	Bit 0
Output 14	Output 13	Output 12	Output 11	Output 10	Output 9	Output 8	Output 7

- QSI has pre-assigned default features to each output but any feature can be assigned to any output in CV 53. In CV 53, the default setting for Output 12 is a Short Air Let-off, or is special for specific types of locomotives such as Pop Off for Steam Locomotives.
- You can specify that F10 control any of Outputs 7-11 and 13-14 in addition to or instead of Output 12.
- Assuming the default CV 53 settings (shown in the top row)⁶⁹, you can specify that F10 control the following features.

Bit 0 Output 7: Dynamic Brakes

“0” Dynamic Brakes are unaffected by F10.
 “1” Dynamic Brakes are affected by F10.

Bit 1 Output 8: Doppler, Start Up

“0” Doppler shift in Forward/Reverse and Start up in Neutral are unaffected by F10.
 “1” Doppler shift in Forward/Reverse and Start up in Neutral are affected by F10.

Bit 2 Output 9: Squealing Brakes and Air Brakes, Long Air Let-off or Special Feature

“0” Squealing Brakes, Air Brakes in Forward/Reverse and Long Air Let-off are unaffected by F10.
 “1” Squealing Brakes, Air Brakes in Forward/Reverse and Long Air Let-off are affected by F10.

Bit 3 Output 10: Audio Mute

“0” Audio Mute is unaffected by F10.
 “1” Audio Mute is affected by F10.

Bit 4 Output 11: Cruise Control, Disconnect-Standby-Total Shut Down

⁶⁹ Features that are different in the Neutral state are shown in parentheses

⁷¹ Write bit operation is supported for CV 45.

- "0" Cruise Control in Forward/Reverse and Disconnect-Standby-Total Shut Down in Neutral are unaffected by F10.
- "1" Cruise Control in Forward/Reverse and Disconnect-Standby-Total Shut Down in Neutral are affected by F10.

Note: Cruise Control was only available on Lionel HO and early BLI locomotives.

Bit 5 Output 12: Speed Report, Status Report

- "0" Speed Report in Forward/Reverse and Status Report in Neutral are unaffected by F10.
- "1" Speed Report in Forward/Reverse and Status Report in Neutral are unaffected by F10.

Bit 6 Output 13: Number Board Lights

- "0" Number Board Lights are unaffected by F10.
- "1" Number Board Lights are affected by F10.

Bit 7 Output 14: Cab Lights

- "0" Cab Lights are unaffected by F10.
- "1" Cab Lights are affected by F10.

4.14 CV 45 Output Location for F11⁷¹

This CV specifies whether outputs 7 thru 14 are controlled by F11.

A '1' in a bit location specifies the output is controlled by F11, while a '0' specifies the output is not controlled by F11.

Default Value: 01000000 = 64

CV 45: Output Location for F11 Register (with Factory Default Features)

Cab Lights	Number Board Lights	SMPH Report (Status Report)	Cruise Control (Disconnect-Standby-Total Shut Down)	Mute	Squealing Brakes – Air Brakes (Brake Set)	Doppler (Start Up)	Dynamic Brakes
Bit 7	Bit 6	Bit 5	Bit 4	Bit 3	Bit 2	Bit 1	Bit 0
Output 14	Output 13	Output 12	Output 11	Output 10	Output 9	Output 8	Output 7

- QSI has pre-assigned default features to each output but any feature can be assigned to any output in CV 53. In CV 53, the default setting for Output 13 is a Short Air Let-off, or is special for specific types of locomotives such as Boiler Blow Down for Steam Locomotives.
- You can specify that F11 control any of Outputs 7-12 and 14 in addition to or instead of Output 13.
- Assuming the default CV 53 settings (shown in the top row)⁷², you can specify that F11 control the following features.

Bit 0 Output 7: Dynamic Brakes

- “0” Dynamic Brakes are unaffected by F11.
- “1” Dynamic Brakes are affected by F11.

Bit 1 Output 8: Doppler, Start Up

- “0” Doppler shift in Forward/Reverse and Start up in Neutral are unaffected by F11.
- “1” Doppler shift in Forward/Reverse and Start up in Neutral are affected by F11.

Bit 2 Output 9: Squealing Brakes and Air Brakes, Long Air Let-off or Special Feature

- “0” Squealing Brakes, Air Brakes in Forward/Reverse and Long Air Let-off are unaffected by F10.
- “1” Squealing Brakes, Air Brakes in Forward/Reverse and Long Air Let-off are affected by F10.

Bit 3 Output 10: Audio Mute

- “0” Audio Mute is unaffected by F11.
- “1” Audio Mute is affected by F11.

⁷² Features that are different in the Neutral state are shown in parentheses

⁷⁴ Write bit operation is supported for CV 46.

Bit 4 Output 11: Cruise Control, Disconnect-Standby-Total Shut Down

“0” Cruise Control in Forward/Reverse and Disconnect-Standby-Total Shut Down in Neutral are unaffected by F11.

“1” Cruise Control in Forward/Reverse and Disconnect-Standby-Total Shut Down in Neutral are affected by F11.

Note: Cruise Control was only available on Lionel HO and early BLI locomotives.

Bit 5 Output 12: Speed Report, Status Report

“0” Speed Report in Forward/Reverse and Status Report in Neutral are unaffected by F11.

“1” Speed Report in Forward/Reverse and Status Report in Neutral are unaffected by F11.

Bit 6 Output 13: Number Board Lights

“0” Number Board Lights are unaffected by F11.

“1” Number Board Lights are affected by F11.

Bit 7 Output 14: Cab Lights

“0” Cab Lights are unaffected by F11.

“1” Cab Lights are affected by F11.

4.15 CV 46 Output Location for F12 ⁷⁴

This CV specifies whether outputs 7 thru 14 are controlled by F12.

A '1' in a bit location specifies the output is controlled by F12, while a '0' specifies the output is not controlled by F12.

Default Value: 10000000 = 128

CV 46: Output Location for F12 Register (with Factory Default Features)

Cab Lights	Number Board Lights	SMPH Report (Status Report)	Cruise Control (Disconnect-Standby-Total Shut Down)	Mute	Squealing Brakes – Air Brakes (Brake Set)	Doppler (Start Up)	Dynamic Brakes
Bit 7	Bit 6	Bit 5	Bit 4	Bit 3	Bit 2	Bit 1	Bit 0
Output 14	Output 13	Output 12	Output 11	Output 10	Output 9	Output 8	Output 7

- QSI has pre-assigned default features to each output but any feature can be assigned to any output in CV 53. In CV 53, the default setting for Output 14 is a Short Air Let-off, or is special for specific types of locomotives such as Boiler Blow Down for Steam Locomotives.
- You can specify that F12 control any of Outputs 7-13 in addition to or instead of Output 14.
- Assuming the default CV 53 settings (shown in the top row)⁷⁵, you can specify that F12 control the following features.

Bit 0 Output 7: Dynamic Brakes

- “0” Dynamic Brakes are unaffected by F12.
- “1” Dynamic Brakes are affected by F12.

Bit 1 Output 8: Doppler, Start Up

- “0” Doppler shift in Forward/Reverse and Start up in Neutral are unaffected by F12.
- “1” Doppler shift in Forward/Reverse and Start up in Neutral are affected by F12.

Bit 2 Output 9: Squealing Brakes and Air Brakes, Long Air Let-off or Special Feature

- “0” Squealing Brakes, Air Brakes in Forward/Reverse and Long Air Let-off are unaffected by F12.
- “1” Squealing Brakes, Air Brakes in Forward/Reverse and Long Air Let-off are affected by F12.

⁷⁵ Features that are different in the Neutral state are shown in parentheses
⁷⁷ See the list of Individual Sound Identifiers in CV 52.

Bit 3 Output 10: Audio Mute

“0” Audio Mute is unaffected by F12.
“1” Audio Mute is affected by F12.

Bit 4 Output 11: Cruise Control, Disconnect-Standby-Total Shut Down

“0” Cruise Control in Forward/Reverse and Disconnect-Standby-Total Shut Down in Neutral are unaffected by F12.
“1” Cruise Control in Forward/Reverse and Disconnect-Standby-Total Shut Down in Neutral are affected by F12.

Note: Cruise Control was only available on Lionel HO and early BLI locomotives.

Bit 5 Output 12: Speed Report, Status Report

“0” Speed Report in Forward/Reverse and Status Report in Neutral are unaffected by F12.
“1” Speed Report in Forward/Reverse and Status Report in Neutral are unaffected by F12.

Bit 6 Output 13: Number Board Lights

“0” Number Board Lights are unaffected by F12.
“1” Number Board Lights are affected by F12.

Bit 7 Output 14: Cab Lights

“0” Cab Lights are unaffected by F12.
“1” Cab Lights are affected by F12.

5 CV 49-64, QSI Configuration Variables

5.1 Overview

Many of the available CV's have been reserved by the NMRA to provide standardized and compatible operation by all manufacturers with each other's products.

The NMRA specified CV specifications relate to the operation of functions that must be standard to all DCC products such as ID numbers, number of speed steps, and acceleration and deceleration values.

However, many model railroad products today, and a much larger number in the future, will require manufacturer unique CV's to configure their product's special features. The command structure and protocols for operation of non-specified features are standardized through the NMRA, but the individual manufacturers will specify the actual behavior and configuration. An example is the system volume for the Quantum Sound System. This feature is not specified by the NMRA and it is left to the discretion of the product designer to determine how it will be implemented and what parameters are necessary to customize its performance. For this reason, the NMRA has provided a number of CV's for the manufacturers to allow configuring of their own products, using CV's 49 through 64. Additional CV's 112-128 have recently been made available for manufacturers as well.

Unfortunately the total number of manufacturer unique CV's made available may not be sufficient for future needs. Also, the grouping of the CV's may not be as well organized as new features are added. For instance, if we included CV's for particular sound effects followed by CV's to set their volume levels, we could easily consume a large number of the available allocated CV's. If at a later date, we decided to add configuration variables to enhance some sound feature, that CV may have to be placed at the end of the list, far from the CV's related to that feature.

5.1.1 Primary and Secondary Indices

Instead of filling up the manufacturer unique CV's in a linear or chronological order, we have elected to use a table indexing system that allows the user to change the operation and behavior of each customizable feature in a consistent way. We have included both a Primary Index set by CV 49 and a Secondary Index (SI) set by CV 50. Numbers or values placed in these two indices do not, by themselves, have any effect on the operation of the Quantum System. Rather, they are used along with CV's that do affect some Quantum characteristic. They simply act as a pointer to individual sounds, features, outputs or whatever that will be affected by the CV under consideration.

5.1.1.1 Primary Index

The Primary Index is used as a table index to expand the number of choices available for a CV.

For example, consider QSI CV 52, which controls the volume levels for different sound features. CV 52 can have any of sixteen volume-settings as specified by the first four bits. Although CV 52 does specify a volume level, it does not know which feature to apply that volume setting to unless there is a way to point at the desired sound feature. That "pointing" is accomplished by using the Primary Index (PI), which is set in CV 49. The user first selects the sound he wants to affect from a table of the different sound features available and enters its corresponding number into the Primary Index, CV 49. He then uses CV 52 to change that particular sound volume. He can enter one value after another into CV 52 until he gets the desired volume for the feature selected. The user can then select a new sound from the table, write its corresponding value into CV 49 and then use CV 52 to change the volume of this second sound.

We use a shorthand notation when writing a CV that has a Primary Index. The CV is first written followed by a decimal point followed the Primary Index value. For instance, if we had set CV 52 to a volume level of 6 for the Bell (Sound Identifier Number⁷⁷ = 8), we would write CV 52.8 = 6.

5.1.1.2 Secondary Index

The Secondary Index is used as a second table index where there is a secondary choice of behavior that can apply. For instance, CV 53 is used to assign features to both an output and a motive state of the locomotive. When we assign a feature in CV 53, we need a pointer (Primary Index) to select the desired output and another pointer (Secondary Index) to specify the state (Forward/Reverse or Neutral).

A useful way to help understand this concept is to picture assigning Secondary and Primary Indexes as row and column values in a two dimensional table for a particular CV (shown as CV X in this case). The Primary Index (PI) is shown as row values and the Secondary Index (SI) is shown as column values. The value of the CV for each PI and SI is shown as a table entry where the row and column (PI and SI) values are included (i.e. "CV Value 1,3" means the Values of CV X assigned for PI = 1 and SI = 3).

CV X Data Register

Primary Index set by CV 49	Secondary Index set by CV 50					
	0	1	2	3	255
0	CV Value 0,0	CV Value 0,1	CV Value 0,2	CV Value 0,3	CV Value 0,n	CV Value 0,255
1	CV Value 1,0	CV Value 1,1	CV Value 1,2	CV Value 1,3	CV Value 1,n	CV Value 1,255
2	CV Value 2,0	CV Value 2,1	CV Value 2,2	CV Value 2,3	CV Value 2,n	CV Value 2,255
3	CV Value 3,0	CV Value 3,1	CV Value 3,2	CV Value 3,3	CV Value 3,n	CV Value 3,255
:	CV Value m,0	CV Value m,1	CV Value m,2	CV Value m,3	CV Value m,n	CV Value m,255
255	CV Value 255,0	CV Value 255,1	CV Value 255,2	CV Value 255,3	CV Value 255,n	CV Value 255,255

Not all of the 256 rows and columns are shown. The row labeled "m" and column labeled "n" indicate any row or column between 3 and 255. Although there is only one CV (shown as CV X in this case), a different value can be stored for each row and column choice, providing up to 256 X 256 possible choices for CV X.

To use CV X, first select the PI and SI you want and assign these values to CV 49 and CV 50 respectively. Now when you enter a value into CV X, it will only apply to that particular selection of CV X for the choices you made for the SI and PI values.

To see how this works in practice, consider CV 53 as an example. The table below shows how different QSI Features have been assigned to different outputs and locomotive states for our factory defaults. The Primary Index column has 14 choices for the 14 different Outputs. The Secondary Index is shown across the top and has only two values (0 for a Motive State, and 1 for Neutral); an N/A means there are no other directional states available and hence no other Secondary ID's besides 0 and 1.

Each Feature ID (see listing of Feature ID's in CV 53) to be controlled by an output is shown as a location in the table corresponding to the desired output and the desired directional state in which it will be active. For instance, we have assigned Mute (ID 64) to Output 10 and to operate in all states (Forward and Reverse, and Neutral). Doppler (ID 65) has been assigned to Output 8 but only in Forward and Reverse. A completely different feature, Locomotive Start Up (ID 144) has been assigned to Neutral. This means that a moving locomotive will produce a Doppler Shift Effect when Output 8 is activated, but will produce a Locomotive Start up effect if in Neutral when Output 8 is activated.

Feature Assignments using CV 53 Primary and Secondary Indexes:

Primary Index set by CV 49		Secondary Index set by CV 50					255 N/A
		0 Forward/ Reverse only	1 Neutral only	2 N/A	3 N/A	
0	N/A						
1	Output 1	96	96				
2	Output 2	97	97				
3	Output 3	3	3				
4	Output 4	1	1				
5	Output 5	211	211				
6	Output 6	8	8				
7	Output 7	5	5				
8	Output 8	65	144				
9	Output 9	216	9				
10	Output 10	64	64				
11	Output 11	177	145				
12	Output 12	178	178				
13	Output 13	105	105				
14	Output 14	101	101				
15	N/A						
:							
255	NA						

Let's say you wanted to assign a Short Air Let-Off (QSI Feature⁷⁸ Number 10) into CV 53 to operate only in Neutral in Output 7. Currently, Output 7 is already assigned "Dynamic Brakes" for both Forward/Reverse and Neutral. To place Short Air Let-off in the Neutral Position for Output 7, first set CV 49 to 7 (Output 7) and then set CV 50 to 1 (Neutral). Now set 10 (Short Air Let-Off) into CV 53.

In summary, to assign a feature to an output, we first chose which output it would apply to, followed by the motive state it will operate in. We use the Primary Index (PI) to select the Output followed by the Secondary Index (SI) to select the motive state and then enter the Feature ID number into CV 53. We then select the next SI for the other motive state and enter the next Feature ID into CV 53.

We use a shorthand notation when writing a CV that has a Primary and Secondary Index. The CV is first written followed by a decimal point followed by the Primary Index value followed by a decimal point followed by the Secondary Index. For instance, in the above example where we entered the Short Air Let-off (10) into CV 53 to be active in Output 7 (PI = 7) and to operate in the Neutral Position (SI = 1), we would write "CV 53.7.1 = 10. When CV's are spoken out in Ops Mode Programming, the same shorthand method is used. If you inquired about the value in CV 53 for this example, you would hear "CV five three point seven point one equals one-zero".

⁷⁸ See CV 53 listing of QSI Feature ID's.

5.2 CV 49 QSI Primary Index

Use CV 49 to specify the Primary Index or Row Number for CV's that use a table index to expand the number of choices.

Default Value:

0

CV 49: Primary Index Register (PI)

Bit 7 (MSB)	Bit 6	Bit 5	Bit 4	Bit 3	Bit 2	Bit 1	Bit 0 (LSB)
P7	P6	P5	P4	P3	P2	P1	P0

CV 49 is used as an index into a table of up to 256 related values.

Primary Index	Table of Values
0	Value[0]
1	Value[1]
2	Value[2]
3	Value[3]
...	...

For example, using CV 49 as an index for CV 52 allows specifying the volume for up to 256 Individual Sounds.

Primary Index	Table of Volumes
0	Volume for Individual Sound[0]
1	Volume [1]
2	Volume [2]
3	Volume [3]
...	...

In this document the terms CV 49 and Primary Index mean the same thing. PI is the abbreviation for Primary Index.

We use a shorthand notation to simplify description of a CV that is composed of a table of values. The elements of the table are referred to as CV NN.PI, where NN is the CV number. For example, Individual Sound Volume 5 is written CV 52.5. During verbal acknowledgement or during CV Numeric Verbal Readout (CV 64) from the locomotive, it is spoken out as "CV five two point five".

5.3 CV 50 QSI Secondary Index

Use CV 50 to specify the Secondary Index for CV's that use two pointers or table indices to expand the number of available choices.

Default Value:

CV 50: Secondary Index Register (SI)

Bit 7 (MSB)	Bit 6	Bit 5	Bit 4	Bit 3	Bit 2	Bit 1	Bit 0 (LSB)
S7	S6	S5	S4	S3	S2	S1	S0

CV 50 is used along with CV 49 as an index into a 2-dimensional table of up to 256x256 related values. CV 49 is the row index and CV 50 is the column index.

Primary Index	Secondary Index				
	0	1	2	3	...
0	Value[0,0]	Value[0,1]	Value[0,2]	Value[0,3]	...
1	Value[1,0]	Value[1,1]	Value[1,2]	Value[1,3]	...
2	Value[2,0]	Value[2,1]	Value[2,2]	Value[2,3]	...
3	Value[3,0]	Value[3,1]	Value[3,2]	Value[3,3]	...
...

- Where Value [n,m] represents the data entered in each position with PI =n, and SI =m.
- In this document the terms CV 50 and Secondary Index mean the same thing. SI is the abbreviation for Secondary Index.
- To simplify description of a CV that is a 2-dimensional table of values, the elements of the table are referred to as CV NN.PI.SI, where NN is the CV number, PI is the Primary Index and SI is the Secondary Index. During verbal acknowledgement of CV's or during CV Numeric Verbal Readout (CV 64), the value of data in a 2-dimensional table is spoken out with the word "point" to distinguish between the CV number, the Primary Index and the Secondary Index. For example, the location of the Feature Assigned to Output 5 in NFF/NFR is written CV 53.5.1 and spoken out as "CV five three point five point 1".

See Example Next Page:

For example, CV 53, using CV 49 as a row index (1.14) and CV 50 as a column index (0.1) allow assigning different QSI Features to each of fourteen outputs for two states: Forward/Reverse, and NFF/NFR.

Primary Index (CV 49)	Secondary Index (CV 50)	
	0	1
1	Feature Assigned to Output 1 in FWD/REV	Feature Assigned to Output 1 in NFF/NFR
2	Feature Assigned to Output 2 in FWD/REV	Feature Assigned to Output 2 in NFF/NFR
3	Feature Assigned to Output 3 in FWD/REV	Feature Assigned to Output 3 in NFF/NFR
4	Feature Assigned to Output 4 in FWD/REV	Feature Assigned to Output 4 in NFF/NFR
5	Feature Assigned to Output 5 in FWD/REV	Feature Assigned to Output 5 in NFF/NFR
6	Feature Assigned to Output 6 in FWD/REV	Feature Assigned to Output 6 in NFF/NFR
7	Feature Assigned to Output 7 in FWD/REV	Feature Assigned to Output 7 in NFF/NFR
8	Feature Assigned to Output 8 in FWD/REV	Feature Assigned to Output 8 in NFF/NFR
9	Feature Assigned to Output 9 in FWD/REV	Feature Assigned to Output 9 in NFF/NFR
10	Feature Assigned to Output 10 in FWD/REV	Feature Assigned to Output 10 in NFF/NFR
11	Feature Assigned to Output 11 in FWD/REV	Feature Assigned to Output 11 in NFF/NFR
12	Feature Assigned to Output 12 in FWD/REV	Feature Assigned to Output 12 in NFF/NFR
13	Feature Assigned to Output 13 in FWD/REV	Feature Assigned to Output 13 in NFF/NFR
14	Feature Assigned to Output 14 in FWD/REV	Feature Assigned to Output 14 in NFF/NFR

For instance, let's say you want to assign the Blower/Fan feature to Output 13 but only in Neutral. The Blower/Fan has a feature Identification Number of "8" (see CV 53 for the list of Feature ID's) and this is the number that will be set into CV 53. However, before writing to CV 53, you will need to specify both the output it will affect and the directional state it will apply to (Forward/Reverse or Neutral). This is done by first setting the Primary Index, CV 49, to "13" to specify Output 13. Next the Secondary Index, CV 50, is set to "1" to specify that this feature is to be operated in Neutral. Now when CV 53 is set to 8 (Blower/Fans), this assignment will apply only to output 13 and the Neutral Direction State. In short hand notation, you have set CV 53.13.1 to 8.

In this way, CV 53 can be used to assign different features to any of the outputs and in any of the two directional states (Forward/Reverse and Neutral). Always remember that when you assign a new value to CV 53, you will first need to verify or set CV 49 and CV 50 to the correct values.

5.4 CV 51 QSI System Sound Control

Use CV 51 to control the Quantum Sound System, Mute Volume and Special Sound Effects

5.4.1 CV 51.0 Operations Mode System Volume (PI = 0)

Use CV 51.0 to change the overall System Volume.

Default
Value:

127

CV 51.0: Ops Mode System Volume Register

Bit 7	Bit 6	Bit 5	Bit 4	Bit 3	Bit 2	Bit 1	Bit 0
0	V6	V5	V4	V3	V2	V1	V0

- Set CV 49 to “0” to specify the Primary Index for **Operations Mode System Volume**.
- The System Volume can be set to any value between 0 (no sound) and 127 (100%). The upper bit is reserved and should be 0. The default Operations Mode Volume is 127 (**100%**). A “0” in this CV will reduce all sound effects to zero volume.

Example: Set the Operations Mode System volume to 64 (50% of max).
--

- | | |
|----|------------------|
| 1) | Set CV 49 to 0. |
| 2) | Set CV 51 to 64. |

The Operations Mode System Volume is the overall sound volume when the locomotive is in normal operation on the main (Operations Mode). When you change the Operations Mode System Volume on the main, you will immediately hear the change in volume.

All sound is turned off in Service Mode because of the limited power usually available for the programming track. If your Command Station supports programming Quantum in Service Mode, you can program the System Volume. You just won't hear the change in volume until you enter Operations Mode.

Note: Setting the system volume in this CV will also apply to the system volume during conventional Analog operation. The converse is also true. Setting the Analog System Volume using Analog program options described in the Analog Operation section of your locomotive's instruction manual will affect the system volume in DCC operation.

5.4.2 CV 51.1 Operations Mode Mute Volume (PI = 1)

Use CV 51.0 to change the Mute Volume. Mute is one of the Quantum features that can be selected by a Function Key. When Mute is activated the overall volume reduces to the volume set by CV 51.1.

Default Value:

0

CV 51.1: Ops Mode Mute Volume Register

Bit 7	Bit 6	Bit 5	Bit 4	Bit 3	Bit 2	Bit 1	Bit 0
0	0	V5	V4	V3	V2	V1	V0

- Set CV 49 to “1” to specify the Primary Index for **Operations Mode Mute Volume**.
- The Mute Volume can be set to any value between 0 (no sound) and 63 (50%). If the Mute Volume is set over 50% of the System Volume set in CV 51.0, the applied Mute Volume will be 50% of the System Volume setting. The upper bit is reserved and should be 0. The default Mute Volume is 0 (**0%**). A “0” in this CV will mute all sound effects to zero volume.

Example: Set the Operations Mode System volume to 32 (25% of max).
--

- | |
|--|
| <ol style="list-style-type: none">1. Set CV 49 to 12. Set CV 51 to 32 |
|--|

The Mute Volume applies when the locomotive is in normal operation on the main (Operations Mode). When you change the Mute Volume on the main and “Mute” has been activated by its assigned Function Key, you will immediately hear the change in volume.

If your Command Station will support programming Quantum in Service Mode, you can program the Mute Volume. You just won't hear the change in Mute volume until you enter Operations Mode and activate the Mute feature.

5.4.3 CV 51.2 Special Sound Effects Enable ⁷⁹ (PI = 2)

Use CV 51.2 to turn on/off special sound effects.

Default Value:

1

CV 51.2: Special Sound Effects Enable Register

Bit 7	Bit 6	Bit 5	Bit 4	Bit 3	Bit 2	Bit 1	Bit 0
Reserved for future use	Reserved for future use	Reserved for future use	Reserved for future use	Reserved for future use	Reserved for future use	Coded Horn for Gas Turbine Start Up ⁸⁰	Horn Triggered Doppler

- Write 2 to CV 49 to specify the Primary Index for **Special Sound Effects Enable**.
- If Horn Triggered Doppler is enabled, you can obtain a Doppler effect by first blowing the Horn for a least one second. Any time thereafter, briefly interrupt the horn signal by releasing the function key and reapplying to produce the Doppler effect.
- Set data in Bit 1 as follows:
 - “0” = Horn Triggered Doppler Effect is disabled
 - “1” = Horn Triggered Doppler Effect is enabled.
- All other bits are reserved. Data in bits 2-7 are not used. Any data entered in these bits will be ignored.
- Default is “1”, Horn Triggered Doppler enabled.

Example: Disable Horn Triggered Doppler.

- | | |
|----|-----------------|
| 1) | Set CV 49 to 2. |
| 2) | Set CV 51 to 0. |

⁷⁹ Write bit operation is supported for Special Sound Effects Enable.

⁸⁰ See Gas Turbine Operation in Appendix II for further explanation of this feature.

5.5 CV 52.PI QSI Individual Sound Volume Control

Use CV 52 to specify volumes levels for individual Quantum sounds.

CV 52.PI: Individual Sound Volume Registers

Bit 7	Bit 6	Bit 5	Bit 4	Bit 3	Bit 2	Bit 1	Bit 0
0	0	0	0	V3	V2	V1	V0

To change the volume level of an individual sound, do the following:

1. Set CV 49 to the identifier for the individual sound (see table below).
 2. Set data in Bits 0-3 of CV 52 as follows:
 - “0” = No sound
 - “1 – 15” = Sets volume level from the lowest level at “1” to the highest level at “15”
- 4 bits of volume are used, providing 16 volume levels. The volume levels are in 2db increments.
 - All other bits are reserved. Data in bits 4-7 are not used. Any data entered in these bits will be ignored.

Example: Set the bell volume to the 6th volume level and then set the Whistle volume to 10th level (i.e. set CV 52.8 to 6 followed by setting CV 52.0 to 11)

1. Set CV 49 to 8 to select the Bell sound.
2. Set CV 52 to 6 to select the 6th volume level for the Bell.
3. Set CV 49 to 0 to select the Whistle/Horn sound.
4. Set CV 52 to 10 to select the 10th volume level for the Whistle/Horn.

Example: For dual Air Pump Steam Locomotives, turn the volume off on one pump to create single pump action.

1. Set CV 49 to 17 to select the second pump sound.
2. CV 52 to zero to select no volume.

5.5.1 Individual Sound Identifiers

Primary Index (CV 49 value)	Sound	Typical Default Levels ⁸¹
0	Whistle/Horn ⁸²	11
8	Bell	11
10	Chuff/Diesel Motor/Traction Motor ⁸³	11
14	Turbo	11
16	Air Pump 1	11
17	Air Pump 2	11
19	Steam Blower (Hiss)/ Fans ⁸⁴	8
21	Long Air Let-off	11
22	Short Air Let-off	11
24	Squealing Brakes	11
26	Steam Dynamo	8
28	Dynamic Brakes	8
29	Boiler Pop-off	11
30	Blow down	11
31	Injector	11
34	Coupler Sounds	11
37	Air Brakes	11

⁸¹ Default levels for individual sounds may be set to different levels at the factory then are shown here depending on the acoustic nature of each locomotive. Check the value of your default settings in your individual locomotive's instruction manual.

⁸² Whistle in Steam Locomotives; Horn in Diesel and Electric Locomotives.

⁸³ Chuff in Steam Locomotives; Diesel Motor in Diesel Locomotives; Traction Motor in Electric Locomotives.

⁸⁴ Steam Blower in Steam Locomotives; Cooling Fans in Diesel and Electric Locomotives.

5.6 CV 53.PI.SI Output Feature Assignment

Use CV 53 to assign QSI features to the 14 decoder outputs.

CV 53.PI.SI: Output Feature Assignment Register

Bit 7	Bit 6	Bit 5	Bit 4	Bit 3	Bit 2	Bit 1	Bit 0
D7	D6	D5	D4	D3	D2	D1	D0

- Write the Decoder Output Number (5... 14) to CV 49.
- Write the Locomotive State (0 for Forward/Reverse, 1 for Neutral (NFF/NFR) to CV 50. Certain features can only be assigned to an output for a specific state.
- Write the QSI Feature Identification Number to CV 53.
- Never assign the same feature to two or more outputs; it is unclear what the effect will be since both outputs may have different states. For instance, if you assign the Blower Hiss to Output 5 and to Output 7, and Output 5 is off but Output 7 is on, would Blower Hiss be on or off?

Example: Set Long Air Let-Off to Output 5 to operate in Forward and Reverse and set Short Air Let-Off to Output 5 to operate in Neutral (i.e. set CV 53.5.0 to 9 and set CV 53.5.1 to 10).

- 1) Set Primary Index CV 49 to "5" to select output 5.
- 2) Set Secondary Index CV 50 to "0" to select Forward/Reverse.
- 3) Set CV 53 to "9" (00000101) which is the Feature ID Number for Long Air Let-Off.
- 4) Set Secondary Index CV 50 to "1" to select Neutral. (CV 49 is already set to output 5.)
- 5) Set CV 53 to "10" (00001010) for Short Air Let-Off.

Now when the locomotive is in Neutral, the Function key mapped to output 5 will produce a Short Air-Let-Off; a Long Air Let-Off when the locomotive is moving in Forward and Reverse.

5.6.1 QSI Feature Identification Numbers

The following table lists the QSI Features, which may be assigned to function key outputs.

The third column shows the directional states (All, Forward/Reverse, Neutral) for which the feature may be assigned to an output. Some features, like Blower Hiss or Mute, apply to all states; some features, like Doppler and Squealing Brakes, only apply to a moving locomotive; some features, like Pop-off or Blow-Down, only apply to Neutral. The Quantum System allows you to assign, say, Squealing Brakes to Output 7 in Neutral but when the F5 Key is pressed to activate this feature in Neutral, it will produce no effect.

Feature ID	Feature	Allowed Directional States	Comments
0	Null Output	All	No feature, no sound effect.
1	Whistle/Horn	All	Pre-assigned to output 4.
3	Bell	All	Pre-assigned to output 3.
5	Dynamic Brakes	All	Dynamic Brakes are usually applied to Diesel or Electric locomotives. Even though it has no meaning for a Steam locomotive, it has some utility when the Steam locomotive is in a Consist. Here Dynamic Brakes cause the chuff sound to lower in labor or volume to be consistent with other locomotives that have Dynamic Brakes. Dynamic Brakes can also be applied in Neutral for Diesels in "Disconnect" which will allow the motor to rev up under Dynamic Brake loading.
8	Blower Hiss/Diesel Cooling Fans	All	Blowers are used on Steam locomotives to vent steam through the smoke stack to provide extra draft for the fire when locomotive is idle. It produces a familiar hissing sound. Diesel and Electric Cooling Fans are used to keep diesels and/or traction motors from overheating. Cooling fan sounds are accompanied by vent opening and closing sounds.
9	Long Air Let-off	All	Use a long air let-off to simulate operating some steam appliances like power reverse.
10	Short Air Let-off	All	Short air let-off for turn on or turn off of some appliances. Combine with brakes to simulate venting air prior to brake sounds.
12	Pop-off	NFF/NFR	This is the sound of the boiler Pop-off valves venting excess steam. Although this can be applied to all directional states, it occurs more typically in Neutral.
13	Blow down	NFF/NFR	This is venting of residue that collects at the bottom of the boiler, usually in Neutral.
14	Injector	NFF/NFR	This is the sound effect of water being injected into the boiler. This can happen anytime but it is more obvious in Neutral.
64	Mute	All	Ideal for muting sounds of a running locomotive when the phone rings. When a locomotive is muted, all sounds go silent. We have added a feature in CV 51.1 that provides a custom mute volume; when Mute is engaged, the sounds go to a lower sound but not completely off.
65	Doppler Shift	FWD/REV	Doppler, when activated, produces volume increase and pitch change on a moving train to

			simulate the sound a train makes when passing close to an observer. Doppler has no meaning or utility in Neutral.
96	Directional Headlight	All	Pre-assigned to output 1. Steam Locomotives Directional Lights also include Dynamo Start Up Sounds.
97	Directional Reverse Light	All	Pre-assigned to output 2. Steam Locomotives Directional Lights also include Dynamo Start Up Sounds.
98	Headlight	All	Turns headlight on/off.
99	Dim Headlight	All	Turns headlight dim/bright.
100	Reverse Light	All	Turns reverse light on/off.
101	Automatic Cab Lights	All	May not be available for all models. Cab Lights turn off in Forward/Reverse after 15 seconds and turn on in Neutral after 10 seconds.
102	Directional Mars Light	All	Come on Bright and Strobing in Direction of travel. Dim in Neutral or when direction is Reverse.
103	Mars Light	All	Turns Mars Light On/Off.
104	Strobe Mars Light	All	Selects Mars Light Strobing or Steady.
105	Number Board Lights	All	May not be available for all models.
107	Directional Headlight + Directional Mars Light	All	Multiple lights feature: a combination of feature 96 and feature 102. If the locomotive has a Mars Light, this is the feature assigned to output 1 by default.
108	Directional Headlight + Directional Ditch Lights	All	Multiple lights feature: a combination of feature 96 and feature 109. If the locomotive has Ditch Lights, this is the feature assigned to output 1 by default.
109	Directional Ditch Lights	All	Ditch Lights on in Forward and off in Neutral and Reverse. Ditch Lights strobe by alternating from "Left Light On; Right Light Off" to "Left Off; Right On", with Horn in Forward and remain strobing for 5 seconds after Horn signal is terminated.
110	Ditch Lights	All	Turns Ditch Lights on/off.
111	Strobe Ditch Lights	All	If Ditch Lights are on, this feature will cause the two Ditch Lights to strobe by alternating from "Left Light On; Right Light Off" to "Left Off; Right On".
144	Start Up	NFF/NFR	The Start Up feature produces locomotive start up sound effects for locomotive that has been Shut Down (see 145).
145	Shut Down	NFF/NFR	Shut Down features consists of three parts that proceeds successively with each use of the Function Key to the stages of: 1) "Disconnect" which allows a diesel motor to rev or steam locomotive to vent steam without engaging the motor, 2) "Standby" which produces low background sounds of an idling locomotive, and 3) Total Shut Down.
176	Air Brakes	FWD/REV	If speed step = 0, and locomotive is moving, Air Brakes feature increases deceleration from CV 4 and CV 24 value progressively as long as Air Brakes active. When turned off, deceleration continues at last braking level. Turning up throttle or entering Neutral resets brakes to off.

177	Cruise Control	FWD/REV	Cruise control locks the locomotive into its current speed when activated. Cruise control works only in Regulated Speed Control and Speed Control, and not Standard Throttle Control. Cruise Control has no meaning or utility in Neutral.
178	Scale Miles Per Hour Report and Status Report	All	In FWD/REV, the locomotive's speed in scale MPH is announced. In Neutral, the locomotive announces its Primary Address (CV 1) or Extended Address (CV 17-18), its Consist Address (CV 19) if it has one, and whether it is in Disconnect, Standby or Shutdown
211	Coupler Effect	All	Although this feature can be applied to all directional states, it has different effects depending on when it is used. If only assigned to FWD/REW it will produce a coupler crash sound. If also enabled in Neutral, it will arm and fire a coupler sound. If it is armed in Neutral, it can also be fired in FWD/REV.
215	Squealing Brakes	FWD/REV	This feature can be re-triggered over and over again anywhere in the record to extend the brake squeal sound. Do not waste this feature in Neutral where squealing brakes have no meaning.
216	Squealing Brakes + Air Brakes	FWD/REV	Combination of features 215 and 176.
217	Pumps	NFF/NFR	This can be two or one compressor depending on the locomotive. Note that when two pumps are available, each one can be assigned different volumes in CV 52.

Note: Do not confuse the above table with the Individual Sound Identifiers Table shown in CV 52. The above table lists ID's of Features while CV 52 table lists ID's of Individual Sounds.

5.6.2 Factory Default Settings

Primary Index (PI) (CV 49 Value)	Output	Secondary Index (SI) (CV 50 Value)		
		0 Forward/Reverse only	1 Neutral only	2 255 N/A
1	Output 1	Directional Headlight (96)	Directional Headlight (96)	
2	Output 2	Directional Reverse Light (97)	Directional Reverse Light (97)	
3	Output 3	Bell (3)	Bell (3)	
4	Output 4	Whistle/Horn (1)	Whistle/Horn (1)	
5	Output 5	Coupler (211)	Coupler (211)	
6	Output 6	Blower Hiss/Fans (8)	Blower Hiss/Fans (8)	
7	Output 7	Dynamic Brakes (5)	Dynamic Brakes (5)	
8	Output 8	Doppler Shift (65)	Start Up (13)	
9	Output 9	Squealing Brakes + Air Brakes (216)	Long Air Let-off (9)	
10	Output 10	Mute (64)	Mute (64)	
11	Output 11	Cruise Control * (177)	Disconnect/Standby/ Shut Down (145)	
12	Output 12	Status Report * (178)	Status Report *(178)	
13	Output 13	Number Board Lights * (105)*	Number Board Lights *(105)*	
14	Output 14	Directional Cab Lights (101) *	Directional Cab Lights (101) *	

* These features may not be included with your model locomotive. Also check your locomotive instruction manual to determine if special features have been assigned to some Outputs.

Note: If no feature is assigned to some Outputs on your locomotive, a Short Air Let-off (10) is usually used as a placeholder. In other words, Outputs that have no standard or special features will activate a Short Air Let-off sound when their assigned Function Keys are pressed.

5.7 CV 55.PI QSI Feature Configuration

Use CV 55 to specify behavior of Quantum features. Use CV 49 to select the QSI feature ID number.

5.7 CV 55.110.5: Ditch Light Strobe Hold Time

This CV specifies the number of seconds the ditch lights remain strobing after a horn blast ends.

Default Value:

5

CV 55.110.5 Ditch Light Strobe Time

Bit 7	Bit 6	Bit 5	Bit 4	Bit 3	Bit 2	Bit 1	Bit 0
Reserved for future use	Reserved for future use	Reserved for future use	D4	D3	D2	D1	D0

- Set CV 55 to the number of seconds you want the Ditch Light Strobe to continue after the horn command is stopped. Range is from 0 to 31 seconds. Default is 5 seconds (00000101 binary, 05 hex).
- Setting the Ditch Light Strobe Hold time will apply to both Analog and DCC operation.

5.8 CV 56.PI QSI Configuration

Use CV 56 to specify Quantum Configuration settings. Use CV 49 to select among the configuration bytes.

5.8.2 CV 56.4: QSI Throttle Mode (PI = 4)

Default
Value:

1

CV 56.4: QSI Throttle Mode Register

Bit 7	Bit 6	Bit 5	Bit 4	Bit 3	Bit 2	Bit 1	Bit 0
0	0	0	0	0	0	D1	D0

- Use this configuration byte to control Quantum Locomotive throttle behavior.
- Set data in Bits 0 and 1 as follows:
 - “0” = Standard Throttle Control.
 - “1” = Speed Control⁸⁵.
 - “2” = Regulated Throttle Control.

Standard Throttle Control (STC) is the common way to control the power delivered to the model locomotive's motor. Under STC, the “power” to the motor is controlled by the throttle setting (speed step) as specified in a speed table. Under throttle control, the speed of the locomotive will change under load such as climbing grades, pulling a heavy train, binding wheels or gears and poor track conditions. In addition, under throttle control, the speed of the locomotive will vary from changes in track voltage, due to power pack resistance, track resistance, inconsistent or intermittent pickups and changes in motor load current.

Speed Control (SC) uses internal motor control electronics to maintain the same speed regardless of varying load or track voltage conditions. Under speed control, the throttle setting (in 128 speed step mode) sets the locomotive's speed in scale miles per hour equal to the throttle setting⁸⁶. Default resolution is in 1-smph increments. If your throttle is set at 35, the locomotive will go 35 smph (scale miles per hour). At 14 or 28 speed steps, you will need to multiple your throttle settings by 9 and 4.5 respectively to determine the locomotive speed.

Under Speed control, CV 2 (V-Start), CV 25 (speed tables), Forward Trim CV 66, Reverse Trim CV 95, and User Defined Speed Tables CV 67 – CV 94, have no meaning and are ignored.

Note: Although some prototype locomotives can achieve 128 miles per hour, most were not designed for these speeds. Hence, increasing the speed setting above the fastest speed obtainable by the model will have no effect. In addition, if your command station cannot supply sufficient voltage for your locomotive to reach its highest speed value, high speed settings will not produce the indicated speed.

Although Speed Control is a big improvement over Standard Throttle Control, it can cause problems when locomotives are in Consists or used as Mid Train Helpers or Pushers. The problem occurs because locomotives can be slightly mismatched in speed. A locomotive that wants to go 36 mph wants to pull the locomotive that is going 35 mph up to speed and will continue to apply more power to do so. The locomotive going 35 mph wants to slow the locomotive going 36 mph and continues to reduce power to do so. This can cause a huge mismatch in locomotive power. Under these conditions, something must give which usually means that wheels will slip. If traction is good for

⁸⁵ Speed Control and regulated throttle control were only available in Lionel HO and early BLI locomotives.

⁸⁶ Because of the way the NMRA has set up speed steps, the actual scale speed is 1 smph less than the speed step indicated (i.e. Speed Step 2 = 1 smph, Speed Step 3 = 2 smph, etc.). Most Command Stations display the throttle setting as 1 less than the speed step (i.e. Speed Step 2 = Throttle Setting 1, Speed Step 3 = Throttle Setting 2, etc.) For those command stations, the throttle setting is equal to scale miles per hour.

all locomotives, the motor power can be very high for some locomotives in the Consist while others are barely working.

Regulated Throttle Control (RTC) combines the best of both Standard Throttle Control and Speed Control. The locomotive still uses speed control circuitry to maintain the locomotive's speed but the speed is allowed to increase or decrease slowly in response to loading. Under RTC, if the locomotive encounters a grade, it does not stop immediately but instead decreases speed slowly in response to the extra loading. If a locomotive encounters a tight curve or if it has to climb a bad track joint at low speed, it passes through or over these obstacles with little change in speed, just like the prototype. The speed step command in RTC is a requested power setting just like Standard Throttle Control except that the locomotive acts like it weights thousands of pounds in response to changing speed.

This is not the same as inertia settings where the locomotive throttle settings vary slowly over time. Under Inertia⁸⁷ settings with Standard Throttle Control, the model locomotive would still stop suddenly if it encounters an obstacle since there is no speed control circuitry to maintain its motion.

RTC provides an advantage when operating Consists. Now if locomotives are slightly mismatched in speed and have unequal loading, they respond to equalize the loading. Within a very short time, all locomotives are working together.

RTC uses all CV's pertaining to throttle, including V-Start, V-High, and all QSI pre-programmed speed curves and user definable speed curves.

- All other bits are reserved. The values of these bits are ignored.
- Default is "1", Speed Control.

Example: Select Regulated Throttle Control
1. Write 4 to CV 49.
2. Write 2 to CV 56.

5.8.3 CV 56.10: Speed Step to Scale MPH Scale Factor (PI = 10)

Default Value:

CV 56.10: Speed Step to Scale MPH Scale Factor Register

Bit 7	Bit 6	Bit 5	Bit 4	Bit 3	Bit 2	Bit 1	Bit 0
D7	D6	D5	D4	D3	D2	D1	D0

- This byte specifies a Scale Factor used with **Speed Control** to change the amount that smph speed changes as a function of speed steps. The value of this byte is interpreted as N/64, which means N = 64 is equivalent to a Scale Factor of 1.0. Some examples of Speed Control with different scale factors are:

CV 56.10	Scale Factor	Slowest possible speed at Speed Step 2	Fastest possible speed at Speed Step 127.
32 (0x20)	0.5	0.5 smph	63 smph
64 (0x40)	1.0	1 smph	126 smph
128 (0x80)	2.0	2 smph	252 smph

⁸⁷ Refer to CV 3, CV 4, CV 23 and CV 24 for Inertia Settings.

Change the Scale Factor when you want a more useful throttle range for a locomotive under Speed Control. This Scale Factor will have no effect if the locomotive is under Throttle Control or Regulated Throttle Control.

You can also use the Scale Factor to increase the accuracy of its speed. If your locomotive's actual scale miles per hour are running a little under the speed step settings, you can change the scale factor to slightly increase all speeds. This is also useful when trying to match locomotives in Consists when all are operating under speed control.

A Scale Factor less than 1.0 is useful when the top speed of the locomotive is much less than 126 smph. For example, suppose a locomotive has a top speed of 60 smph. With a Scale Factor of 1.0, all speed steps from 61 through 127 will result in a speed of 60 smph. If the Scale Factor is set to 0.5, then the top speed of 60 smph will correspond to speed steps 121 and above.

A Scale Factor greater than 1.0 is useful when the top speed of the locomotive is much greater than 126 smph. For example, suppose a locomotive has a top speed of 200 smph. With a Scale Factor of 1.0 the locomotive would only go up to 126 smph. If the Scale Factor were set to 2.0, then the top speed of 200 smph would be obtained at speed steps 101 and above.

The advantage of a Scale Factor of "1" for command stations with an LCD display is to easily know the locomotive's speed. If you do not have a visual readout, it is best to set the Scale Factor to provide the best throttle range.

5.8.3 CV 56.12: Chuff Interval Scale Factor⁸⁸ (PI = 12)

Default Value:

CV 56.12: Chuff Interval Scale Factor Register

Bit 7	Bit 6	Bit 5	Bit 4	Bit 3	Bit 2	Bit 1	Bit 0
D7	D6	D5	D4	D3	D2	D1	D0

- This byte specifies a Scale Factor used to determine the amount of time between chuffs. This is inversely related to the chuff rate or the number of chuffs per wheel revolution; the larger the scale factor (more time between chuffs), the slower the chuff rate (fewer chuffs per wheel revolution). The value of this byte is interpreted as N/32, which means N = 32 is equivalent to a Scale Factor of 1.0.

Some examples of chuff rate with different scale factors are:

CV 56.12	Scale Factor	Chuffs Per Wheel Revolution
32 (0x20)	1.0	4
43 (0x2B)	1.3	3
64 (0x40)	2.0	2
128 (0x80)	4.0	1

To calculate the scale factor for a desired number of chuffs per wheel revolution, use the formula Scale Factor = (4 / N) * 32, where N is the number of chuffs per revolution.

Use this Scale Factor to fine-tune the chuff rate. For example, if your locomotive chuffs a little slower than four per revolution, you can change the scale factor to 31 (0.97) to slightly increase the number of chuffs per revolution. Or if your locomotive chuffs a little faster than four per revolution, you can change the scale factor to 33 (1.03) to slightly decrease the number of chuffs per revolution.

⁸⁸ All QSI equipped steam locomotives since 1-July-04 support CV56.12 Chuff Interval Scale Factor which is available on all version 6 software and includes all Life Like and the BLI PRR K4, C&O Texas and all following models.

Note: We recommend that you set your chuff rate at some speed value greater than 2 smph.

5.8.4 CV 56.128: Reset to Factory Default (PI = 128)

Default Value:

NA

CV 56.128: Reset to Factory Default Register

Bit 7	Bit 6	Bit 5	Bit 4	Bit 3	Bit 2	Bit 1	Bit 0
0	0	0	0	0	0	0	D0

- Use this configuration byte to reset CV's to factory default values.
- Use the Secondary Index to select a range of CV's. Only those CV's in the selected range will be reset; those CV's outside the range are left unchanged.

SI	Reset Operations:
51	Reset CV 51, System Sound Control
52	Reset CV 52, Individual Sounds
53	Reset CV 53, Function Output Mappings
55	Reset CV 55, QSI Feature Control
56	Reset CV 56, QSI Configuration
253	Reset all standard NMRA CV's
254	Reset all QSI CV's
255	Reset all CV's

- Write the QSI Manufacturer Number, 113, to CV 56, to execute the reset operation.
- In Operations Mode you will hear 3 whistle hoots when the reset operation completes.

Note: "Reset all CV's" may not work correctly in Service Mode on some command stations, because the command station may turn off the track power before the operation is complete. If this happens, reset CV's in separate groups or use Ops Mode Programming.

Example: Reset Quantum to original factory defaults (i.e. Reset all CV's)

1. Set CV 49 to 128.
2. Set CV 50 to 255.
3. Set CV 56 to 113.

Example: Reset the Individual Sound Volumes to factory defaults

1. Set CV 49 to 128.
2. Set CV 50 to 52.
3. Set CV 56 to 113.

5.8.5 CV 56.129: Locomotive ID Access (PI = 129)

Default Value:

N/A

CV 56.129: Locomotive ID Access Register

Bit 7	Bit 6	Bit 5	Bit 4	Bit 3	Bit 2	Bit 1	Bit 0
D7	D6	D5	D4	D3	D2	D1	D0

- Use this index with CV 56 if your controller will not allow you to program your locomotives ID on the main, and programming on the programming track is impossible due to insufficient power from your command station.
- This feature is only supported during Operations Mode programming. It will not work during Service Mode programming.
- Use CV 50 to select between Short Address (CV 50 = 1), High Byte Extended Address (CV 50 = 17) and Low Byte Extended Address (CV 50 = 18).
- When CV 56.129.1 is written, the data byte is written to CV 1. If programming acknowledgement is enabled, you will hear "CV 1 equals <short address>". The data byte must be in the range 1 to 127.
- When CV 56.129.17 is written, the data byte is merely stored in temporary memory. There is no verbal program announcement. The data byte must be in the range of 0xC0 to 0xE7.
- When CV 56.129.18 is written, the two data bytes are written to CV 17 and CV 18, making the locomotive's ID the 2 byte address consisting of the byte written to CV 56.129.17 and the byte written to CV 56.129.18. If you want to verify the full address in Ops Mode, set CV 64 to 17 (or 18) and hear "CV 17 (or 18) equals <long address>".

Note: When programming the Extended Address, you must set CV 56.129.17 before you set CV 56.129.18.

See the CV 17 and CV 18 documentation for description of how to compute and enter the MSB (most significant byte) and the LSB (least significant byte) of your Extended Addresses.

Step-by-Step procedure for entering your short (Primary) address in CV 56.129 in Ops Mode.

- 1) Find out if your command station accepts Decimal, Binary or Hex⁸⁹ inputs for CV entries.
- 2) Set CV 49 to 129.
- 3) Set CV 50 to 1.
- 4) Set CV 56 to your short address. Hear the address spoken back.
- 5) Change CV 29, bit 5 to "0" to allow operation with your new primary address (see CV 29).

Example: Set your locomotive's ID to the short address "23"

1. Set CV 49 to 129 decimal (10000001, 0x81).
2. Set CV 50 to 1.
3. Set CV 56 to 23 decimal (00010111, 0x17). Hear "CV One equals two, three". At this point, the locomotive must be selected as 23 to proceed to step 4.

If you were using the extended addressing to do steps 1-3, then set CV 29 to 34 decimal (00000010, 0x02) for Primary Address Enable and 28/128 Speed Step.

Your locomotive's short ID is now 23 and ready to operate.

⁸⁹ Hex and Binary numbers are not shown in the following examples. If you require Hex or Binary, use the conversion table in Appendix IX.

Step-by-Step procedure for entering your long in CV 56.129 in Ops Mode.

1. Find out if your command station accepts Decimal, Binary or Hex inputs for CV entries.
2. Determine the MSB and LSB for your Extended Address (See CV 17/18 instructions and example).
3. Set CV 49 to 129.
4. Set CV 50 to 17.
5. Enter CV 17 (Most Significant Byte) as a Decimal, Binary or Hex number required by your command station. You will hear no verbal response.
6. Next enter CV 18 (Least Significant Byte) as a Decimal, Binary or Hex number. Hear the new full address spoken back.
7. Change CV 29, bit 5 to "1" to allow operation with your new Extended Address (see CV 29).

The following table shows examples for some common train numbers. Just follow the procedure above when entering CV 17 and CV 18.

ID Number	CV 17 (MSB) (Dec)	CV 18 (LSB) (Dec)	CV 17 (MSB) (Hex)	CV 18 (LSB) (Hex)	CV 17 (MSB) (Binary)	CV 18 (LSB) (Binary)
3985	207	145	CF	91	11001111	10010001
3989	207	149	CF	95	11001111	10010101
3708	206	124	CE	7C	11001110	01111100

Example 1: Set your locomotive's long address to "3985" (Also see example under CV 17 and 18.)

1. Set CV 49 to 129 decimal (10000001, 0x81).
2. Set CV 50 to 17 decimal (00010001, 0x11).
3. Set CV 56 to 207 decimal (11001111, 0xCF), which is the MSB for your address (you will hear no verbal feedback).
4. Set CV 50 to 18 decimal (00010010, 0x12).
5. Set CV 56 to 145 decimal (10010001, 0x91), which is the LSB for your address. Hear "CV one, seven equals three, nine, eight, five".
6. Set CV 29 to 34 decimal (00100010, 0x22) for Extended Address Enable and 28/128 Speed Step.

Your locomotive's Long ID is now 3985 and ready to operate.

Example 2: Set your locomotive's long address to "5344" (See example under CV 17 and 18.)

1. Set CV 49 to 129 decimal (10000001, 0x81).
2. Set CV 50 to 17 decimal (00010001, 0x11).
3. Set CV 56 to 212 decimal (11010100, 0xD4), which is the MSB for your address (you will hear no verbal feedback).
4. Set CV 50 to 18 decimal (00010010, 0x12).
5. Set CV 56 to 224 decimal (11100000, 0xE0), which is the LSB for your address. Hear "CV one, seven equals five, three, four, four".
6. Set CV 29 to 34 decimal (00100010, 0x22) for Extended Address Enable and 28/128 Speed Step.

Your locomotive's Long ID is now 5344 and ready to operate.

5.8.6 CV 56.254⁹⁰: About Quantum Decoder (PI = 254)

Use this CV in Service Mode to read back information about your Quantum Decoder. Use CV 50 to select among the data bytes to retrieve.

Default Value:

NA

Bit 7	Bit 6	Bit 5	Bit 4	Bit 3	Bit 2	Bit 1	Bit 0
D7	D6	D5	D4	D3	D2	D1	D0

- Information from this CV is retrieved in Service Mode as a response to a VERIFY_BYTE or VERIFY_BIT operation.
- To select which byte of information to retrieve, write data to CV 50 as follows:
 - “4” = Retrieve Product Model High Byte.
 - “5” = Retrieve Product Model Low Byte.
 - “8” = Retrieve Firmware Build Number.
 - “10” = Retrieve Firmware Build Date.Month (1...12).
 - “11” = Retrieve Firmware Build Date.Day (1...31).
 - “12” = Retrieve Firmware Build Date.Year (02 = 2002).
- The Firmware Version Number can be retrieved from CV 7, Manufacturer's Version Number.

Example: Retrieve the Product Model

- Write 254 to CV 49.
- Write 4 to CV 50.
- Read back CV 56. Store the returned value in H.
- Write 5 to CV 50.
- Read back CV 56. Store the returned value in L.
- The Product Model = (H * 256) + L.

5.8.7 CV 56.255: Play Build Information (PI = 255)

Default Value:

NA

CV 56.255: Play Build Information Register

Bit 7	Bit 6	Bit 5	Bit 4	Bit 3	Bit 2	Bit 1	Bit 0
0	0	0	0	0	0	D1	D0

- Information from this CV is delivered as audio verbal output and is restricted to Operations Mode.
- Write data to CV 56 as follows:

⁹⁰ This CV is not in BLI Hudson software ho300a02.

- “0” = Play Product Identifier: you will hear the Product Identification number (e.g. “300” or “400”). This identifies the type of locomotive and the sounds programmed into the software.
- “1” = Play Version; you will hear two sets of numbers separated by the word “point”. The first number set is the version number and the second is the build number (e.g. “one point five” means Version 1, Build 5).
- “2” = Play Build Date This is the date the software was released. You will hear three sets of numbers, each separated by a pause. The first number set is the month, followed by the day of the month, followed by the year (e.g. “six” pause “one five” pause “zero two” means June 15, 2002).

- Any value other than 0, 1, or 2 will be ignored and there will be no verbal output.

Note: While the Build Information is playing, all incoming DCC packets are ignored.

Example: Play Version

7. Write 255 to CV 49.
8. Write 1 to CV 56.
9. Hear Version spoken out: for Version 1, Build 6, you would hear “one point six”.

5.9 CV 62⁹¹ QSI Control⁹²

Use this CV to enable or disable Programming Verbal Acknowledgement.

Default Value:

1

CV 62: QSI Control Register

Bit 7	Bit 6	Bit 5	Bit 4	Bit 3	Bit 2	Bit 1	Bit 0
0	0	0	0	0	0	0	D0

- Write data to CV 62 as follows:

“0” = Disable Programming Verbal Acknowledgement

“1” = Enable Programming Verbal Acknowledgement

Example: To Disable Programming Verbal Acknowledgement

1. Set CV 62 to 0.

Note: Unlike Analog Operation, we do not have a separate and fixed Program Volume since there is no verbal reporting from the Programming Track. Verbal reporting is available during Ops Mode Programming. The overall System Volume sets the volume for these verbal responses. If you cannot hear your Ops Mode verbal responses, you will need to turn up the System Volume during programming.

Note: If you cannot hear verbal responses during Ops Mode programming, check to see if you have activated the Mute feature.

⁹¹ This CV does not exist in version ho300a02 (Hudson Steam). For that version use CV 56.0 System Configuration.

⁹² Write bit operation is supported for CV 62.

5.10 CV 64 CV Numeric Verbal Readout (Verbal CV Inquiry)

Use this CV to hear the value of any CV spoken as a decimal number. This works only in Operations Mode.

Default Value:

NA

CV 64: Numeric Verbal Readout Register

Bit 7	Bit 6	Bit 5	Bit 4	Bit 3	Bit 2	Bit 1	Bit 0
D7	D6	D5	D4	D3	D2	D1	D0

5.10.1 Standard NMRA CV's

- Write the number of any standard NMRA CV to CV 64.

Note: While the Verbal Readout is playing, all incoming DCC packets are ignored.

Example: Hear the current setting for CV 2 V-Start.

1. Write 2 to CV 64.
2. Hear the value spoken out: if the value of CV 2 were "32", you would hear "CV two equals three two".

- Writing either 17 or 18 to CV 64 will produce a verbal response indicating the full value of the Extended Address.

5.10.2 QSI CV's

- Determine the Primary Index for the value you want to know. If a Primary Index is required, write the Primary Index number to CV 49.
- Determine the Secondary Index for the value you want to know. If a Secondary Index is required, write the Secondary Index number to CV 50.
- Write the number of the QSI CV to CV 64.

Note: While the Verbal Readout is playing, all incoming DCC packets are ignored.

Example: Hear the current setting or the bell volume.

1. Set CV 49 to 8. (The Individual Sound Identifier for Bell is "8"; see table in CV 52)
2. Set CV 64 to 52.
3. Hear the Bell volume spoken out: if the bell volume were 13, you would hear "CV five two point eight equals one three".

Note: Unlike Analog Operation, we do not have a separate and fixed Program Volume since there is no verbal reporting from the Programming Track. Verbal reporting is available during Ops Mode Programming. The overall System Volume sets the volume for these verbal responses. If you cannot hear your Ops Mode verbal responses, you will need to turn up the System Volume during programming.

Note: If you cannot hear verbal responses during Ops Mode programming, check to see if you have activated the Mute feature.

6.1 CV 66 Forward Trim

Forward Trim specifies a scale factor by which a voltage drive level should be multiplied, when the controller is driving the unit in the Forward Direction.

Default Value:

128

CV 66: Forward Trim Register

Bit 7 (MSB)	Bit 6	Bit 5	Bit 4	Bit 3	Bit 2	Bit 1	Bit 0 (LSB)
D7	D6	D5	D4	D3	D2	D1	D0

- Trim factor preserves the same curve shape as specified in the speed table but allows a simple multiplying factor to scale it larger or smaller for “trimming” its speed behavior in Forward. This allows making fine adjustments to match the speed of other locomotives, and to match the locomotive’s Reverse speed characteristics.
- The multiplying scale factor is $n/128$ where “n”, the Forward Trim Factor, can be any number entered into CV 66 from 0 to 255. If $n = 128$, then multiplying scale factor is 1 resulting in no change to the speed curve.
- If Forward Trim Factor is “0”, then Forward Trim is not implemented.
- If Forward Trim Factor is between 1 and 128 than the voltage applied to the motor is decreased by a multiplying factor that varies from .00775 to .99225.
- If Forward Trim Factor is between 130 and 255 than the voltage applied to the motor is increased by a multiplying factor that varies from 1.0078 to 1.977.
- CV 66 only applies if the speed tables are activated in CV 29 by setting bit 4 = 1.

6.2 CV 67-94 User Defined Speed Table

CV 67 – 94 allows the user to specify a speed table that is suitable for the operation his locomotive.

CV 67-94: User Defined Speed Registers

Bit 7 (MSB)	Bit 6	Bit 5	Bit 4	Bit 3	Bit 2	Bit 1	Bit 0 (LSB)
D7	D6	D5	D4	D3	D2	D1	D0

- The speed table consists of 28 data points for each of 28 speed steps. A value of 255 means full voltage applied to the motor while a value of 0 means no additional voltage applied to the motor over the V-Start voltage (CV 2).
- If you select 14 speed steps, every other data value is used. If you select 128 speed steps, extra points will be interpolated between each of the 28 data points to provide a smooth curve consisting of 255 points.
- The User Defined Speed Table must be enabled by setting CV 29, bit 5 to 1 and CV 25 bit 1 to 0 or 1.
- Default Values:

CV #	Speed Step	Default Value
CV 67	Speed Step 1	0
CV 68	Speed Step 2	9
CV 69	Speed Step 3	18
CV 70	Speed Step 4	28
CV 71	Speed Step 5	37
CV 72	Speed Step 6	47
CV 73	Speed Step 7	56
CV 74	Speed Step 8	66
CV 75	Speed Step 9	75
CV 76	Speed Step 10	85
CV 77	Speed Step 11	94
CV 78	Speed Step 12	103
CV 79	Speed Step 13	113
CV 80	Speed Step 14	122
CV 81	Speed Step 15	132
CV 82	Speed Step 16	141
CV 83	Speed Step 17	151
CV 84	Speed Step 18	160
CV 85	Speed Step 19	170
CV 86	Speed Step 20	179
CV 87	Speed Step 21	188
CV 88	Speed Step 22	198
CV 89	Speed Step 23	207
CV 90	Speed Step 24	217
CV 91	Speed Step 25	226
CV 92	Speed Step 26	236
CV 93	Speed Step 27	245
CV 94	Speed Step 28	255

6.3 CV 95 Reverse Trim

Reverse Trim specifies a scale factor by which a voltage drive level should be multiplied, when the controller is driving the unit in the Reverse direction.

Default Value:

CV 95: Reverse Trim Registers

Bit 7 (MSB)	Bit 6	Bit 5	Bit 4	Bit 3	Bit 2	Bit 1	Bit 0 (LSB)
D7	D6	D5	D4	D3	D2	D1	D0

- Trim factor preserves the same curve shape as specified in the speed table but allows a simple multiplying factor to scale it larger or smaller for “trimming” its speed behavior in Reverse. This allows making fine adjustments to match the speed of other locomotives, and to match the locomotive’s Forward speed characteristics.
- The multiplying scale factor is $n/128$ where “n”, the Reverse Trim Factor, can be any number entered into CV 66 from 0 to 255.
- If Reverse Trim Factor is “0”, then Reverse Trim is not implemented.
- If Reverse Trim Factor is between 1 and 128 than the voltage applied to the motor is decreased by a multiplying factor that varies from .00775 to .99225.
- If Reverse Trim Factor is between 130 and 255 than the voltage applied to the motor is increased by a multiplying factor that varies from 1.0078 to 1.977.
- CV 95 only applies if the speed tables are activated in CV 29 by setting bit 4 = 1.

Appendix I

Sounds Available Under DCC Operation

Steam Sounds

1.1 Automatic Sounds

Steam Chuff: The familiar steam chuff comes from steam exhausted from the steam chest through the smoke stack, which creates a powerful draft to feed the fire. QSI Quantum chuffing produces four distinct chuff sounds per drive wheel setting a rhythm recognized by all steam fans. Our software allows the chuffs to partly overlap to create a more realistic effect; one chuff sound does not need to terminate before the next one begins.

Articulated Chuff: The Quantum System has two sets of steam chuff sounds that will go gradually in and out of synchrony as the locomotive moves around the layout. Most prototype articulated locomotives had less weight over the front engine, which resulted in more slippage, causing the two engines to run at slightly different speeds.

Blower or Steam Locomotive Hiss: The steam from the steam chest venting through the smokestack also draws air through the firebox, keeping the fire healthy. When the locomotive is sitting still, blowers are often turned on to vent the steam and maintain the draft as well as keep smoke out of the locomotive cab. The blower sound on Quantum Steam Locomotives is a continual steam hiss heard in Neutral.

Air Pumps: Air pumps come on whenever air is used. After a Long Air Let-off in Neutral, usually signifying the operation of the power reverse, you will hear the pumps start up at maximum rate to replace the air lost from the reservoir. Once the pressure is up, the pumps only turn on occasionally to maintain pressure.

Air Release: Compressed air is used on locomotives for the braking system and for operating various appliances like the reversing mechanisms common on large steam locomotives. When a large steam locomotive comes to a stop, you will hear a Long Air Let-off as the power reverse is moved to the center Neutral Position.

Brake Squeal: Brake squeal on prototype locomotives is usually most noticeable when the wheels are just about to stop turning. Listen for brake squeal sounds as the Quantum locomotive slows to a stop.

Steam Pop-off: If there is too much steam in the boiler, special pop-off valves or “safeties” on top of the locomotive release the excess pressure in a fury of hissing sound. This happens most often when the locomotive is sitting still, since the fire continues to build up steam that is not used. The Quantum pop-off sound comes on for random lengths, at random times in Neutral.

Steam Water Injector: The water used to make steam is replaced by water injectors operating at high pressure to overcome the elevated pressure in the boiler. The sound of rushing water and steam hiss ends with a distinctive valve shut off. This sound comes on for random lengths of time and occurs randomly when the locomotive is in Neutral.

Steam Boiler Blow Down: As water evaporates, minerals and other residues settle to the bottom of the boiler. The fireman opens a valve to vent this material through a large pipe under the side of the cab onto the ground. Quantum’s blow down sound occurs completely at random for undetermined lengths of time when the locomotive is in Neutral.

1.2 Controllable Sounds

Whistle: The whistle has a distinctive start up followed by a steady whistle sound, then enters an ending sound effect immediately after you stop the whistle signal. Use the whistle Function Key to produce any combination of long or short blasts, and the whistle will react properly. Quantum Sound also includes a short hoot that is shorter and more appropriate than using the normal whistle start up followed by the end effect. You can now produce series of short hoots before starting out or for signaling.

Bell: The bell on steam locomotives may be either hand pulled or pneumatic depending on the size and manufacturing date of the locomotive. Pull bells have a distinctive ding-dong sound as the bell moves towards and then away from the observer. With pull bells, you can sometimes hear the squeak of the bushings as the bell swings to and fro. Mechanical bells used a pneumatic clapper and produced a very regular striking pattern. The bells on steam locomotives are loud, because they are mounted high up on the locomotive. In addition, some bells made during World War II were manufactured from steel rather than brass. You can tell the more harsh

sound of the steel bell from the more melodic sound from brass bells. Quantum uses a variety of different bell sounds from hand pulled, pneumatic, steel and brass bell types.

Doppler Run-by: Instantly recognizable, the locomotive sounds get louder as the train approaches, then immediately drops to a much lower pitch and lower volume as the train passes by. With a little practice you can change the pitch exactly when and where you want.

The QSI patented Doppler Run-by responds to the speed of the locomotive, so the sounds change more dramatically when the locomotive is running faster. After the Doppler shift has occurred and the whistle is no longer being blown, the locomotive's volume and sound pitch subtly return back to normal.

Flanges or Extended Brakes: When a train enters a curve, the flanges on the wheels tend to ride up on the inside of the rail and squeal. Recreate this squealing effect by pressing and releasing the Brake Sound Function Key button quickly and repeatedly as necessary. Or for slow stops, use the same function key to produce long protracted squealing brake sounds.

Air Brakes: When prototype train brakes are applied, air is released from the brake lines to reduce the pressure. The more the pressure is reduced, the greater the braking. You will hear a continual air release sound from the locomotive model as braking is continually increased. The longer the air is released, the quicker the locomotive model will slow down. Once all the pressure is released, the locomotive will continue at maximum braking which can still require a long stopping distance depending on your Load settings.

Dynamic Brakes: Steam Locomotives do not have Dynamic Brakes. When steam locomotives are operated today, they are often coupled to a diesel to provide dynamic brakes on down grades. If a Quantum Steam locomotive is coupled to a Quantum Diesel, and Dynamic Brakes are activated, the Diesel Dynamic Brake effect will start up and the Steam locomotive labored chuffing will reduce at the same time. Since prototype dynamic brakes are relatively ineffective at low speeds, the Dynamic Brakes will shut off automatically below 8 smph and Steam Locomotive Chuff will return to normal.

Coupler: To give you the most authentic coupler sounds, QSI has identified three distinct types of coupler activity. The first is when the coupler is armed where you will hear the clanking sound of the coupler lift bar and coupler pin raising. The next is the coupler opening, with the hiss of the air-lines parting. The third is when the locomotive couples up to its load of cars, and you hear the crash as all the cars bunch together from the impact.

Locomotive Shut Down (Extended): The Air Pumps will turn off, followed by the sounds of Pop Off⁹³ Operating for about ten seconds and finally the Blower Hiss will shut off.

Locomotive Start Up (Extended): The Dynamo will rev up while the Headlight comes on gradually, then the Cab Lights (if available) will turn on, followed by the Air Pumps, the Steam Blower will turn on and then the locomotive will enter normal operation.

Diesel Sounds

2.1 Automatic Sounds

Diesel Motor Rev: Quantum allows Diesel Motors to be operated with all eight notches corresponding to the throttle notches used on the prototype. As the throttle is turned up, the Diesel Motor RPM will increase in fixed increments until the maximum RPM occurs at notch 8. All eight notches are evenly distributed between 0 and the maximum speed step.

Diesel Turbo: Some QSI diesels have a turbo effect – a very distinctive high-pitched whine. Turbo appliances are used to improve the locomotives horsepower by pumping air into the intake manifold under pressure. The power to activate the turbo motor comes from the locomotive exhaust pressure. QSI Turbo sounds are separate from the Diesel Motor sound, which allows the Turbo effect to lag the motor when the Diesel Motor is revving down or revving up, just like the prototype.

Cooling Fans: The enormous Diesel Motors and generators enclosed in the diesel cab need ventilation to stay cool. All diesel locomotives have powerful cooling fans on the roof to draw outside air through louvers on the sides of the locomotive. When cooling fans start, you will also hear the sounds of louvers opening. When cooling fans shut down, you will hear the louvers close.

⁹³ Some Steam Locomotives may not produce a Pop-Off effect during shut down.

Air Pumps: When a locomotive is sitting still, the pumps come on in a steady beat to replace the air lost from the brake air release or any other air operated appliances. Once the pressure is up, the pumps only turn on occasionally to maintain the pressure. Diesel Air Pumps are operated directly from the motor and are quite noticeable when turned on in a non-moving locomotive. In Forward, you will hear the Air Pumps come on soon after the horn is operated to maintain the air pressure.

Air Release: Compressed air is used on locomotives for the braking system and operating various appliances. You will hear either a Short Air Let-off or Long Air Let-off at various times.

Brake Squeal: You can hear the brake squeal on prototype locomotives when the locomotive is moving slowly and can become particularly loud when the wheels are just about to stop turning. Listen at slow speeds for constant brake squeal sound and the final distinctive squealing sounds as the diesel slows to a stop.

Quick Locomotive Start Up. All diesel locomotives have a quick Start Up and Shut Down effect when a locomotive is selected. Protracted turn-on effects are available when locomotives are in Total Shut Down (see Controllable Sounds below).

2.2 Controllable Sounds

Air Horns: The Quantum system uses authentic locomotive sounds whenever possible. The Quantum horn has been recorded from a variety of diesel locomotives. The number of chimes and the manufacturer usually characterizes air horns. Quantum horns include single chime horns found on early F units, as well as multi-chime horns more common on modern diesels. In addition, all diesels include a special short horn blast. If you blow the horn briefly, you will produce a realistic short horn sound or "hoot".

Bells: Diesels and electric locomotives, as well as larger steam locomotives, usually have pneumatically operated mechanical bells. Diesel bells can be as distinctive as steam bells. They are characterized by their tone, clapper rep rate and their location in the locomotive. In addition, it often takes time to get the clapper up to speed on the prototype or to shut down. When the Quantum Bell is turned on in Neutral, you will hear the wheezy sound of the pneumatic clapper starting up before the bell starts to ring and you will hear the bell fade out with soft rings along with the Short Air Let-off sound associated with turning this appliance off.

Doppler Run-by: The locomotive sounds get louder as the train approaches, then immediately drop to a much lower pitch and lower volume as the train passes by. With a little practice you can change the pitch exactly when and where you want. Doppler shift is based on the speed of the locomotive, so the sounds change more dramatically when the locomotive is running faster. After the Doppler shift has occurred and the horn is no longer being blown, locomotive sounds return to normal.

Flanges or Extended Brakes: When a train enters a curve, the flanges on the wheels tend to ride up on the inside of the rail and squeal. Recreate this squealing effect by pressing and releasing the Brake Sound function key button quickly and repeatedly as necessary. Or for slow stops, use the same function key to produce long protracted squealing brake sounds.

Air Brakes: When prototype train brakes are applied, air is released from the brake lines to reduce the pressure. The more the pressure is reduced, the greater the braking. You will hear a continual air release sound from the diesel locomotive model as braking is continually increased. The longer the air is released, the quicker the locomotive model will slow down. Once all the pressure is released, the locomotive will continue at maximum braking which can still require a long stopping distance depending on your Load settings.

Dynamic Brakes: Electric motors can act as motors or generators depending on whether they are using power or generating power. When used as generators, the traction motors are disconnected from taking power from the locomotive's prime mover, and instead are connected to large resistor grids in the roof. By increasing the resistive load on the traction motors, the traction motors become harder to turn and act as brakes for the locomotive. The electric power generated by turning the traction motors is dissipated as heat by the resistor grid. These resistor arrays get quite hot and require cooling. When Dynamic Brakes are turned on in the Quantum equipped Diesel locomotive, the Diesel Motor sound drops to notch 1 and the Dynamic Brake cooling fan sounds come on. Since dynamic brakes are relatively ineffective at low speeds, the Dynamic Brakes will shut off automatically below 8 smph.

Coupler: To give you the most authentic coupler sounds, QSI has identified three distinct types of coupler activity. The first is when the coupler is armed where you will hear the clanking sound of the coupler lift bar and coupler pin raising. The next is the coupler opening, with the hiss of the air-lines parting. The third is when the locomotive couples up to its load of cars, and you hear the crash as all the cars bunch together from the impact.

Low Idle: Low Idle is used on prototype locomotives to maintain a warm and ready locomotive with a minimum of fuel consumption. The special Low Idle sound has a lower base throb and is less harsh than the normal idle.

Locomotive Shut Down (Extended): The Air Pumps will turn off, as will the Number Board Lights, followed by the sounds of the Cooling Fans shutting off, the Louvers closing, the Diesel Motors shutting down and finally, the engineer's door opening and shutting.

Locomotive Start Up (Extended): The engineer's door will open and close, then the Number Board Lights will turn on, followed by Vents opening, the two Diesel Motors starting up one at a time (if two motor diesel), the Air Pumps starting up, and the locomotive entering normal operation.

Electric Locomotive Sounds

3.1 Automatic Sounds

Traction Motor Whine: Although both diesels and electric locomotives have traction motors, electric locomotives do not have loud diesel engines drowning out the sounds of the traction motors. You will hear the traction motors when Electrics starts out, especially if the cooling fan volume is turned down to a lower value. Like the prototype, the Quantum traction motor whine pitch increases and decreases with the speed of the locomotive. It is not affected by track voltage, only the speed.

Cooling Fans: The electric traction motors get quite hot from the enormous current supplied to their circuits. All electric locomotives have powerful cooling fans that can create so much draft the access panel doors cannot be opened when the fans are operating at full power. It is not surprising that these fans can easily be heard in idling and operating locomotives.

Air Pumps: When a locomotive is sitting still, the pumps come on in a steady beat to replace the air lost from the brake air release or any other air operated appliances. Once the pressure is up, the pumps only turn on occasionally to maintain the pressure. Air pumps are electrically operated and are quite noticeable if the fans are turned down or off.

Air Release: Compressed air is used on locomotives for the braking system and operating various appliances. You will hear either a Short Air Let-off or Long Air Let-off at various times.

Brakes: You can hear the brake squeal on prototype locomotives when the locomotive is moving slowly and can become particularly loud when the wheels are just about to stop turning. Listen at slow speeds for constant brake squeal sound and the final distinctive squealing sounds as the Electric Locomotive slows to a stop.

3.2 Controllable Sounds

Horn: The Quantum system uses authentic locomotive sounds whenever possible. The Quantum horn has been recorded from a prototype single chime GG-1 at a passenger station. All Quantum horns and whistles are engineered by our sound experts to give you the most authentic effects. If you blow the horn briefly, you will produce a realistic short horn sound or "hoot".

Bell: Diesels and electric locomotives, as well as larger steam locomotives, usually have pneumatically operated mechanical bells. The Quantum Electric Locomotive bell was recorded from the prototype. When the bell is shut off, you will hear the bell fade out along with the Short Air Let-off sound associated with turning this appliance off.

Doppler Run-by: The locomotive sounds get louder as the train approaches, then immediately drop to a much lower pitch and lower volume as the train passes by. With a little practice you can change the pitch exactly when and where you want. Doppler shift is based on the speed of the locomotive, so the sounds change more dramatically when the locomotive is running faster. After the Doppler shift has occurred and the horn is no longer being blown, locomotive sounds return to normal.

Flanges or Extended Brakes: When a train enters a curve, the flanges on the wheels tend to ride up on the inside of the rail and squeal. Recreate this squealing effect by pressing and releasing the Brake Sound Function Key button quickly and repeatedly as necessary. Or for slow stops, use the same function key to produce long protracted squealing brake sounds.

Air Brakes: When a prototype trains brakes are applied, air is released from the brake lines to reduce the pressure. The more the pressure is reduced, the greater the braking. You will hear a continual air release sound from the Electric Locomotive model as braking is continually increased. The longer the air is released, the quicker the locomotive model will slow down. Once all the pressure is released, the locomotive will continue at maximum braking which can still require a long stopping distance depending on your Load settings.

Dynamic Brakes: Electric locomotives do not have Dynamic Brake sounds. However, the Dynamic Brake function has been included to make the Quantum Electric Locomotive consistent with other Quantum equipped locomotives in a consist. If Dynamic Brakes are activated, the Traction Motor Sound-of-Power will reduce to the lowest setting since It would be inconsistent for an Electric Locomotive to be working at full Sound-of-Power while Dynamic Brakes are being applied to other locomotives within the same consist. When Dynamic Brakes are shut off, the traction motor sounds will return to normal Sound of Power. Since prototype dynamic brakes are relatively ineffective a low speeds, the Dynamic Brakes will shut off automatically below 8 smph.

Coupler: To give you the most authentic coupler sounds, QSI has identified three distinct types of coupler activity. The first is when the coupler is armed where you will hear the clanking sound of the coupler lift bar and

coupler pin raising. The next is the coupler opening, with the hiss of the air-lines parting. The third is when the locomotive couples up to its load of cars, and you hear the crash as all the cars bunch together from the impact.

Locomotive Shut Down (Extended when using the F9 Shut Down key): The Air Pumps will turn off, Cab Lights will turn off, followed by the sounds of the Louvers being closed and the engineer's door being opened and shut.

Locomotive Start Up (Extended when using the F6 Start UP key): The engineer's door will open and close, then the Cab Lights will turn on, followed by the Air Pumps, Directional Lights, Vents opening and then the locomotive will enter normal operation.

Gas Turbine Sounds

4.1 Automatic Sounds

Diesel Motor Rev: The diesel used in the prototype was a Cummings 250 horsepower motor. Under diesel control in RTC or SC throttle mode, the Gas Turbine top speed is limited to 25 smph. Quantum allows the Diesel Motor to be operated over eight notches corresponding to the throttle notches used on most prototype diesels. As the throttle is turned up, the Diesel Motor RPM will increase in fixed increments until the maximum RPM occurs at notch 8. All eight notches are evenly distributed between 0 and 80 speed step. Although the locomotive will not exceed 25 smph, the motor can still be revved through all notches.

Turbine Whoosh: The Gas Turbine produced an almost deafening roar that seemed to drown out all but the horn. It was sometimes referred to as “The Big Blow” since its dominant sound was that of furiously rushing exhaust gas. We have modeled this effect by synthesizing this sound in the Quantum system until it sounded exactly like the prototype turbine. We have coupled this effect to our Sound of Power™ concept to provide labored Turbine Whoosh when the locomotive is under heavy load.

Turbine Whine: Some witnesses to the prototype Gas Turbine maintain there is no Turbine Whine, such as the sound that a jet airplane would make. However, other witnesses say that there was a discernable whine as the turbine was revving up that could still be barely heard at idle. We have included a separate whine sound in the Quantum System, which can easily be heard during the transition from diesel to turbine sounds, and which is almost buried in the Turbine Whoosh sound when the turbine is “on the line”.

Cooling Fans: The diesel motors and generators and enormous turbine enclosed in the Gas Turbine cab need ventilation to stay cool. All diesel and turbine locomotives have powerful cooling fans on the roof to draw outside air through louvers on the sides of the locomotive. When Cooling Fans start, you will also hear the sounds of Louvers opening. When Cooling Fans shut down, you will hear the Louvers close.

Air Pumps: When a locomotive is sitting still, the pumps come on in a steady beat to replace the air lost from the brake air release or any other air operated appliances. Once the pressure is up, the pumps only turn on occasionally to maintain the pressure. Air Pumps are operated directly from the Diesel Motor or from two electric motors when the turbine is “on the line”. Air pumps are quite noticeable when turned on in a non-moving locomotive in Diesel Mode.

Appliance Air Release: Compressed air is used on locomotives for the braking system and operating various appliances. You will hear either a Short Air Let-off or Long Air Let-off at various times.

Brake Squeal: You can hear the brake squeal on prototype locomotives when the locomotive is moving slowly and can become particularly loud when the wheels are just about to stop turning. Listen at slow speeds for constant brake squeal sound and the final distinctive squealing sounds as the Gas Turbine slows to a stop.

Quick Engine Start Up. All diesel locomotives have a Quick Start Up and Shut Down effect when a locomotive is selected. Protracted turn-on effects are available when locomotives are in Total Shut Down (see Controllable Sounds below).

4.2 Controllable Sounds

Air Horns: The horn used for the Gas Turbine is a single chime horn usually found on early F units. Some commercial videotapes of the Gas Turbine have dubbed a multi-chime horn in for sound effects and do not represent the actual locomotive horn. In addition, the Gas Turbine horn includes a special short horn blast. If you blow the horn briefly, you will produce a realistic short horn sound or “hoot”.

Bells: Diesels and electric locomotives, as well as larger steam locomotives, usually have pneumatically operated mechanical bells. Diesel bells can be as distinctive as steam bells. They are characterized by their tone, clapper rep rate and their location in the locomotive. In addition, it often takes time to get the clapper up to speed on the prototype or to shut down. When the Quantum Bell is turned on in Neutral, you will hear the wheezy sound of the pneumatic clapper starting up before the bell starts to ring and you will hear the bell fade out with soft rings along with the Short Air Let-off sound associated with turning this appliance off.

Transition from Diesel to Turbine and Ignition: Starting the gas turbine was a complex procedure which required considerable time for the turbine to be at full power. We have shortened the amount of time to start the turbine in the model but preserved much of the important procedures necessary to bring the turbine “on the line”. This includes first ramping up the diesel one notch to start the turbine rotating to the point where it would fire. The firing of the gas turbine model sounds a bit like lighting a large industrial gas furnace. At this point the turbine

starts revving up with its distinctive whine coupled with a low level Whoosh. The diesel is then revved up further followed by the turbine whine and whoosh increasing up to the point where the diesel disconnects and returns to idle. Shortly after this, the turbine is ramped up to full power where the Whoosh or roar now dominates the Turbine Whine.

Transition from Turbine to Diesel: Turning off the turbine was almost as complex as turning it on. The diesel is first ramped up to engage the turbine at full RPM. The turbine is dropped down to idle and the turbine throttle is reduced to zero. The Diesel Motor is maintained at full power to allow the turbine to cool over about 40 seconds; during this period, the Turbine Whoosh is first reduced to off while the Turbine Whine is gradually reduced to zero. After the turbine is completely shut down, the Diesel Motor returns to idle.

Doppler Run-by: The locomotive sounds get louder as the train approaches, then immediately drop to a much lower pitch and lower volume as the train passes by. With a little practice you can change the pitch exactly when and where you want. Doppler shift is based on the speed of the locomotive, so the sounds change more dramatically when the locomotive is running faster. After the Doppler shift has occurred and the horn is no longer being blown, locomotive sounds return to normal.

Flanges or Extended Brakes: When a train enters a curve, the flanges on the wheels tend to ride up on the inside of the rail and squeal. Recreate this squealing effect by pressing and releasing the Brake Sound function key button quickly and repeatedly as necessary. Or for slow stops, use the same function key to produce long protracted squealing brake sounds.

Dynamic Brakes: Electric motors can act as motors or generators depending on whether they are using power or generating power. When used as generators, the traction motors are disconnected from taking power from the locomotive's prime mover, and instead are connected to large resistor grids in the roof. By increasing the resistive load on the traction motors, the traction motors become harder to turn and act as brakes for the locomotive. The electric power generated by turning the traction motors is dissipated as heat by the resistor grid. These resistor arrays get quite hot and require cooling. When Dynamic Brakes are turned on under diesel operation, the Diesel Motor sound drops to notch 1 and the Dynamic Brake cooling fan sounds come on. Under Turbine operation, the Turbine sound will drop to its lowest Sound of Power setting but since the Turbine Whoosh stays relatively constant and loud, it may be difficult to hear the Dynamic Brake sounds. Since dynamic brakes are relatively ineffective at low speeds, the Dynamic Brakes will shut off automatically below 8 smph.

Coupler Sounds: To give you the most authentic coupler sounds, QSI has identified three distinct types of coupler activity. The first is when the coupler is Armed where you will hear the clanking sound of the coupler lift bar and coupler pin raising. The next is Firing the coupler, where you hear the opening of the coupler with the hiss of the air-lines parting. The third sound occurs when the locomotive couples up to its load of cars, and you hear the Coupler Crash as all the cars bunch together from the impact.

Low Idle: Low Idle is used on prototype diesel locomotives to maintain a warm and ready locomotive with a minimum of fuel consumption. The special Low Idle sound has a lower base throb and is less harsh than the normal idle.

Locomotive Shut Down (Extended): The Air Pumps will turn off, as will Directional Lighting, followed by the sounds of the Cooling Fans shutting off, the Louvers closing, the Diesel Motors shutting down and finally, the engineer's door opening and shutting.

Locomotive Start Up (Extended): The engineer's door will open and close, followed by Vents opening, the Diesel Motor starting up, the Air Pumps starting up, and the locomotive entering normal operation.

Appendix II

Prototype Gas Turbine Design and Operation

Introduction

The Veranda Gas Turbines were powerful locomotives, developing 4,500 horsepower with 138,000 lbs of tractive effort at start up. As a point of comparison, the N & W J 4-8-4 steam locomotive provided 80,000 lbs, and the largest steam locomotive, the UP Big Boy, provided 135,000 lbs of tractive effort. The popular GP series diesels were rated at 2000 hp with a maximum of 65,000 lbs of tractive effort. The gigantic UP DD40AX Centennials come close with 134,000 lbs of tractive effort. Later large two-unit turbines developed over 8,500 horsepower but the Veranda retained its distinction of having the largest internal combustion engine in a single power unit.

The Verandas were designed for freight operation with a top speed of 65 mph.

The advantage of all gas turbines for Union Pacific was their ability to operate on inexpensive heavy oil called “Bunker C” that was readily available on long UP desert lines. The chief disadvantages of gas turbines were their lower efficiency than diesels particularly at low speeds and their tendency towards corrosion. The Bunker C caused both fouling and corrosion of the turbine blades over time and the heavy oil was difficult to handle. Turbines carried their own steam boilers to preheat the Bunker C to 240 degrees to be suitable for combustion in the turbines. These problems combined with the increasing price of Bunker C and competition from new more efficient and powerful diesels, caused the demise of the Gas Turbines. However, the UP Verandas were a success story. They performed well for the UP from 1952 to when they were retired in the early sixties. The more advanced two unit turbines served the UP up to December of 1969 when the last gas turbine was retired.

Design and Description

The Veranda Gas Turbine used two different methods to power the locomotive; a 4500 horsepower gas turbine and a 250 horsepower diesel motor.

Diesel Motor: this was a Cummings Diesel Motor that powered three different machines:

- 1.
2. **Diesel Generator:** The diesel generator, in turn, had three different functions:
 - a) Provide electrical power to charge batteries and power for d-c auxiliaries when turbine power was shut down.
 - b) To motor one of the main traction generators to crank turbine for starting.
 - c) To power two of the eight traction motors low power locomotive movement in the yard (hostling). During hostling, there was no battery charging or air compressor operation.
3. **Diesel Alternator:** This was belt driven from the diesel motor to provide three-phase a-c auxiliary power to run the radiator-fan motors, starting fuel-pump motor, and water booster-pump motor until turbine is up to idling speed.
4. **Air Compressor:** This was also belt driven from the diesel motor to pump up main reservoir air pressure until the two motor driven air compressors take over during battery charging. This is primarily intended for use during hostling and turbine cranking.

The diesel motor was not used to provide additional power during normal operation or when starting the locomotive from a dead stop.

Gas Turbine: This was the main power plant rated at 4,500 horsepower. It is an oil burning, axial flow gas turbine. It delivers power through a single reduction gearbox to drive four traction generators, an auxiliary generator and a turbine alternator.

The traction generators are excited by four amplidyne exciters and furnish power to eight traction motors. Power is controlled in 20 steps by the main handle of the master controller. There are four independent power circuits, each consisting of a traction generator and two traction motors. The following connections are obtained during locomotive operation:

1. Series-connected traction motors, full field.
2. Series-connected traction motors, shunted fields.
3. Parallel-connected traction motors, full field.
4. Parallel-connected traction motors, shunt fields.

Transitions are automatically controlled as a function of locomotive speeds.

While the field current was determined as a function of speed, the series parallel connection of the motors was determined by selection handle. The choices of the selection handle were OFF at the left followed by motor position, M1, motoring position M2, and BRAKE to the right.

The turbine alternator is a three-phase, six-pole machine driven by the turbine and supplies power to the a-c auxiliary system.

The auxiliary generator driven by the turbine furnishes power for d-c auxiliaries and battery charging when turbine is running and "on the line".

Operation

The Turbine Control Switch, TC, has four positions and along with the Turbine Control Switch Light, controls and monitors diesel-motor and turbine operations.

Starting the Diesel Motor (TC1):

1. Move TC switch to position 1 and all necessary switches and breakers must be closed.
2. Close battery switch BVS.
3. Close breaker TB1 – Turbine generator, Diesel Start.
4. Close breaker TB3 – Coolant pump.
5. Close breaker TB12 – Diesel alternate field (this breaker should normally be left closed). The following sequence will happen:
 - Coolant water pressure switch picks up.
 - Battery charge timing relay, **T-BC**, picks up.
 - Fuel pressure relay, **FPR** picks up.
 - **MF TEMP** lamp lights.
 - **LUB PRS** lamp lights.
 - Sequence relay, **T-SQ**, picks up.
 - Fuel dump solenoid valve, **FDSV**, is energized.

Momentarily depress the engine-start button, **ES**.

- a) The diesel crank timing relay, T-DC, picks up and remains closed for 20 seconds. Engine cranks for 20 seconds and fires within this period.
- b) Ten seconds later battery charging power is supplied from diesel generator.
- c) After battery charging commences, the motor driven train air compressors run to supply main reservoir air. Also the diesel alternator is excited to furnish ac auxiliary power to necessary ac auxiliaries only. At this time, lights can be turned on.

Note: The turbines diesel did not have an air start. It was also started from the batteries.

The diesel motor can now be used to do hostling of the locomotive. Because of the notoriously inefficient operation of the gas turbine power plant at idle and low speeds, hostling was usually done using the diesel motor. To move the locomotive using the diesel motor:

- 1) Close propulsion control breaker, TB4.
- 2) Move reverse handle to FORWARD or REVERSE.
- 3) Move Selector Handle to M1 position.

Note: When operating the diesel, the selector handle connects motors in series, M1, or in parallel, M2. Maximum diesel RPM in M2 is 843 rpm.

- 4) Advance throttle to 1st and then to 2nd notches.
- 5) To increase speed above 10 mph, move throttle handle to IDLE, then move Selector Handle to motoring position, M2, and again advance throttle handle to notch 1 and then to 2.

Note: The UP operation manuals do not seem to indicate the top speed in M2. Using the speed ratios for an F7 between series and parallel connections gives a speed ratio of 2.79 independent of gear ratios. I would guess the same holds true for the Turbine diesel. This would give a top speed of about 28 mph.

Note: In the Mighty Turbine video and on independent recordings, there is a high pitch whine when the motor is idling. Since it does not seem likely that the diesel motor would have a turbo and the turbine is not running, this is likely the sound of the gearbox.

Turbine Cranking (TC2)

When Turbine Control Switch, **TCS**, indicating lamp (green) on engineer's instrument panel lights, **TC** Switch can be advanced to **Position 2**, at which time the following occurs in the sequence listed below which takes about 3-5 minutes:

- TCS lamp goes out.
- Battery charging and motor driven air compressors nullified.
- Diesel generator is coupled to traction generators G4 to crank turbine (with diesel engine operating at idling speed).
- When turbine reaches 10-15 percent of speed (about 700 rpm), a limited amount of diesel fuel is admitted to turbine.
- Ignition is turned on.
- Atomizing air is fed to turbine.
- Turbine fires.
- Generator main field is weakened.
- Diesel engine governor is advanced to top speed.
- Turbine accelerates toward top speed.
- Generator G4 uncouples from diesel generator and turbine operates at IDLE speed.
- Diesel engine returns to IDLE speed and diesel generator reconnected for battery charging and air compressor operation.
- Turbine alternator furnishes power to traction motor blower motors, amplidyne drive motors, main lube pump motor.

Fuel Transfer (TC3)

When TCS green indicator lamp again goes on after the above 3-5 minute sequence finishes, TC switch can be moved to position 3. The following then occurs over about one minute:

- Turbine auxiliary generator (dc) takes over battery charging function and supplies control power. Air compressors come on line.
- Fuel transfer mechanism operates progressively to transfer fuel from diesel oil to "Bunker C" within 40 seconds.

Turbine “ON THE LINE”

When **TCS** green indicator lamp relights after the 1-minute sequence above, **TC** Switch can be moved to position 4.

- Diesel motor shuts down.
- Turbine alternator takes over to supply auxiliary ac power to all ac motors.
- Turbine is “on the line” and locomotive is ready for operation.

Setting Turbine Speeds

Under normal conditions, turbine speed is adjusted for idle speed of 5,175 rpm using rheostat R# while having the turbine running in TC4, TH, IDLE, RH OFF and SR OFF. To adjust top speed, install reverse handle, throttle up to notch 13 slowly and adjust rheostat, R14A. Top speed is 6900 plus or minus 70 rpm.

Moving the Locomotive Under Gas Turbine Power”

- Move reverse handle to FORWARD or REVERSE, depending on direction desired.
- Move selector handle to MOTORING position **M1** or **M2** position as required.

Note: The Selector Handle sets the turbine at idle in motor position, M1, or full turbine operation, M2.

- Make sure handbrake is released
- Advance throttle handle as quickly as possible to the position that starts locomotive. Observe limitations of loadmeter and do not permit notching guide pointer to make prolonged indications in the RED band. Reduce throttle position if necessary.
- Operate locomotive according to loadmeter and notching guild limitations.

Stopping the Locomotive”

- Move throttle handle to IDLE and apply air brakes.
- If leaving engineers position, move selector and reverse handles to OFF.

Dynamic Brakes”

- When Selector Handle is moved to Brake, the turbine goes to idle and dynamic brakes are applied. Resistor grid cooling fans come on automatically.

Reversing the Locomotive

- Bring locomotive to a full stop.
- Move reverse handle to opposite direction.
- Release brakes.
- Continue operation according to *Moving the Locomotive Under Gas Turbine Power* described above.

Shutting Down the Locomotive

- Turn turbine control switch, **TC**, to position 1. Diesel motor automatically starts and gas turbine shuts down in approximately 4½ minutes.

Note: When fuel was cut to the turbine, without power, it probably took only about thirty seconds to completely stop. However, the diesel was allowed to operate to run the turbine with just air moving through the blades. I understand this was done to prevent heat damage to the blades. Assume that the diesel motor continued at full speed for about forty minutes followed by the diesel shutting down to idle, followed by the turbine winding down to off.

Leaving the Locomotive

- Set handbrake and close windows and doors.
- Move throttle handle to OFF.
- Move selector handle to OFF.
- Move reverse handle to OFF and remove handle.

Approximate Prototype Event and Timing Graphs

Diesel Start Up

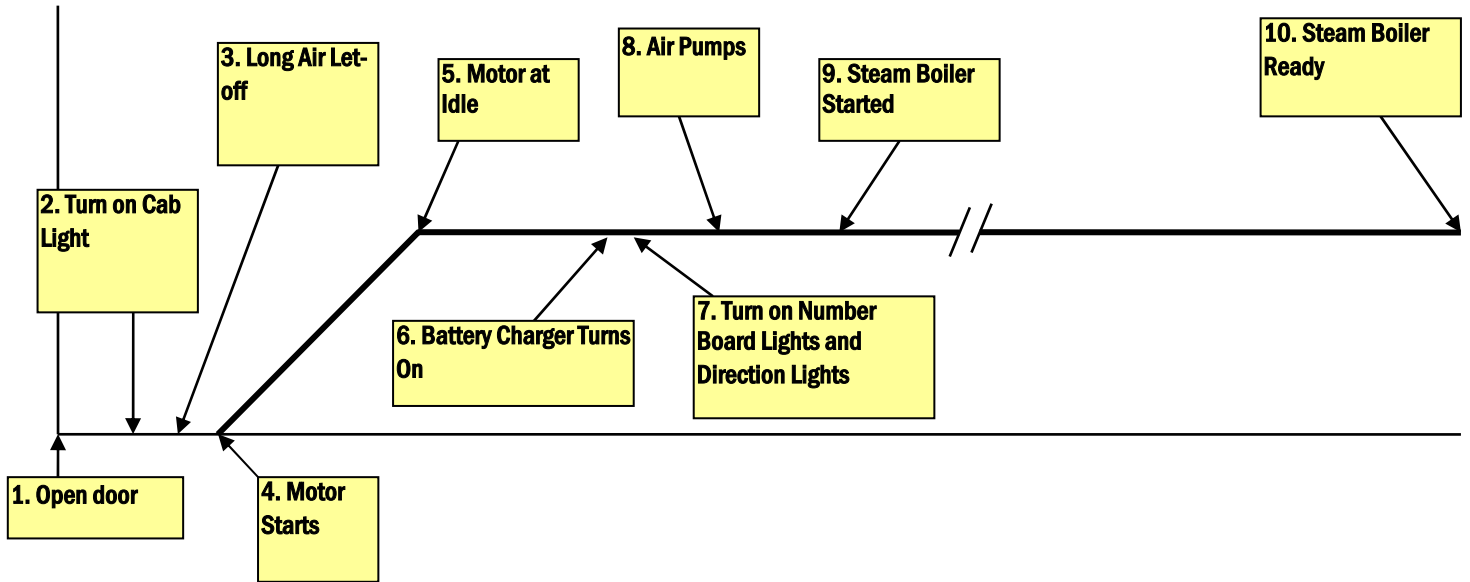

Turbine Start Up

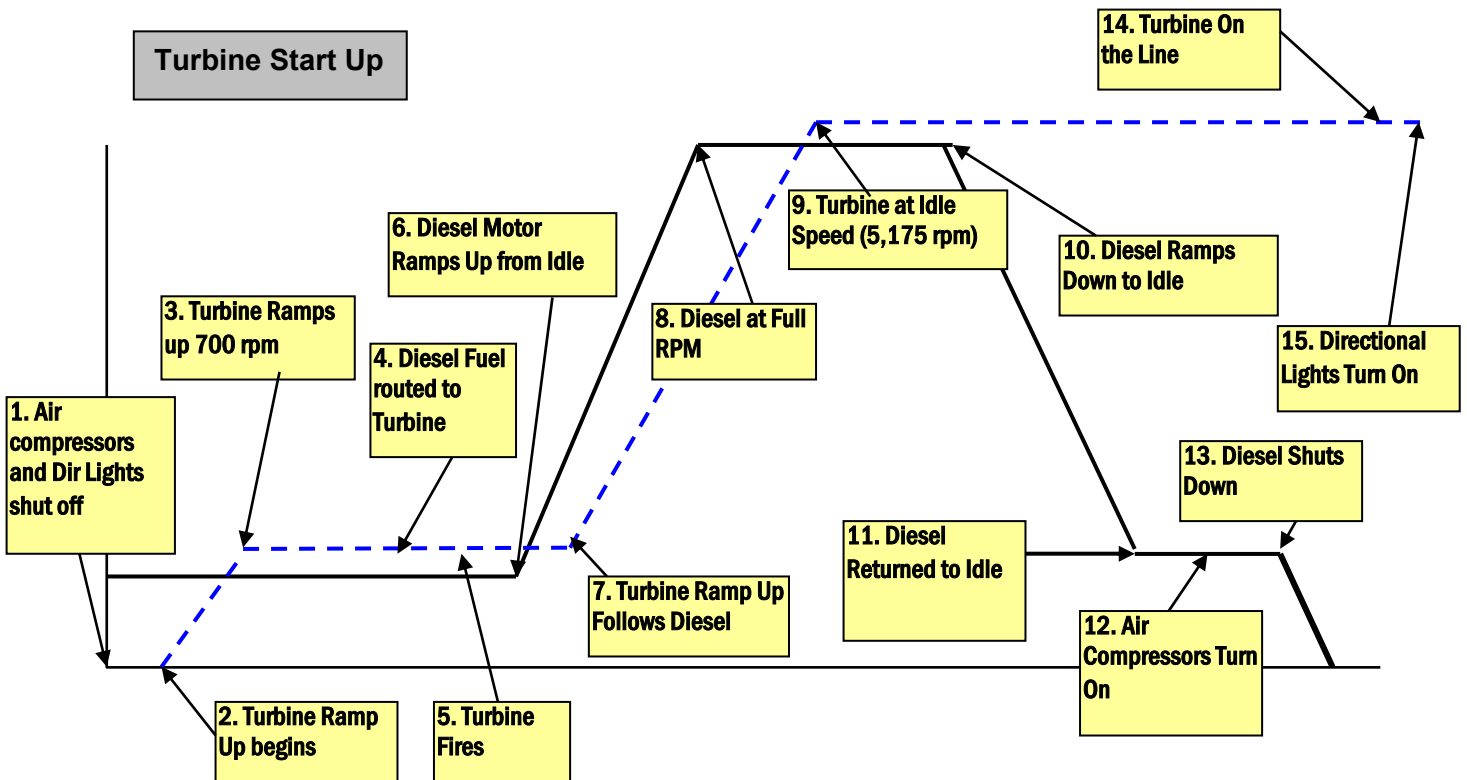

Diesel Shut Down

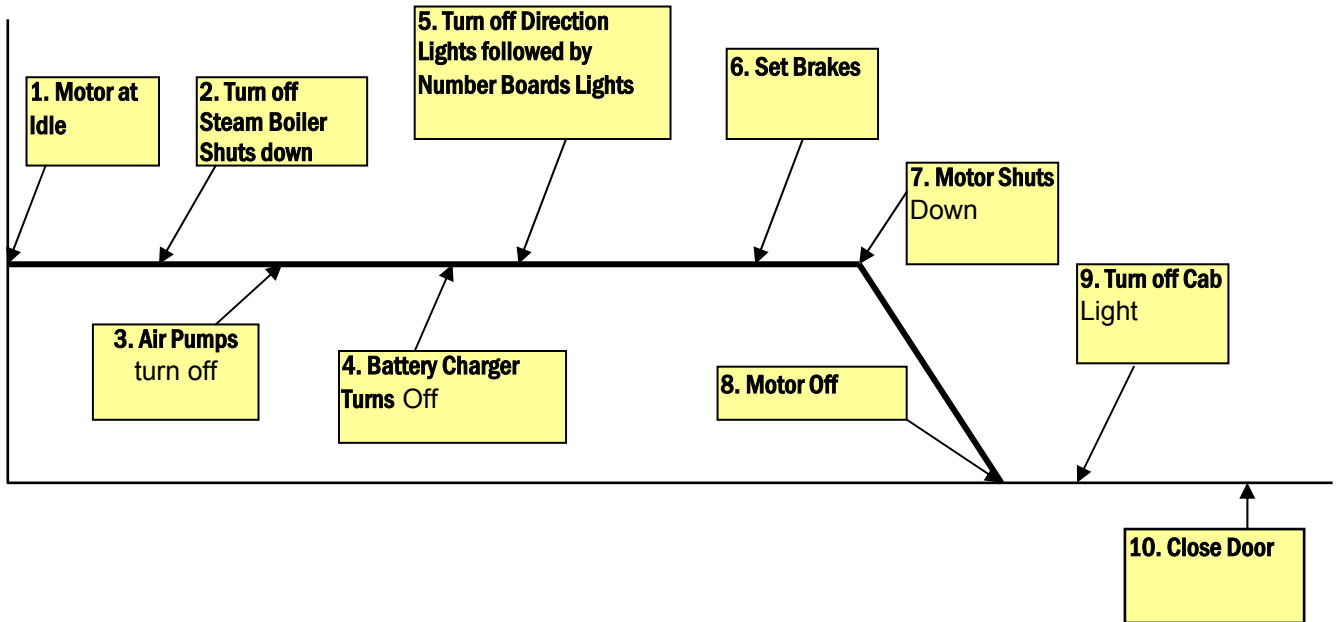

Diesel Operation

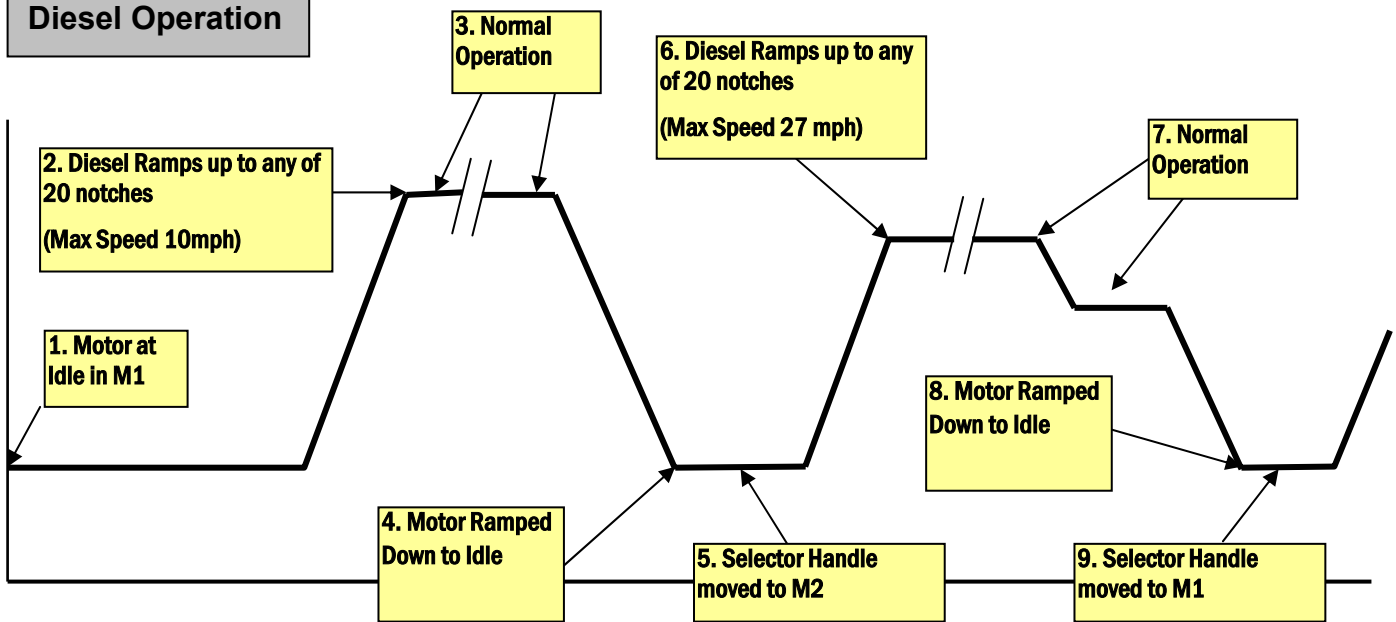

Turbine Shut Down

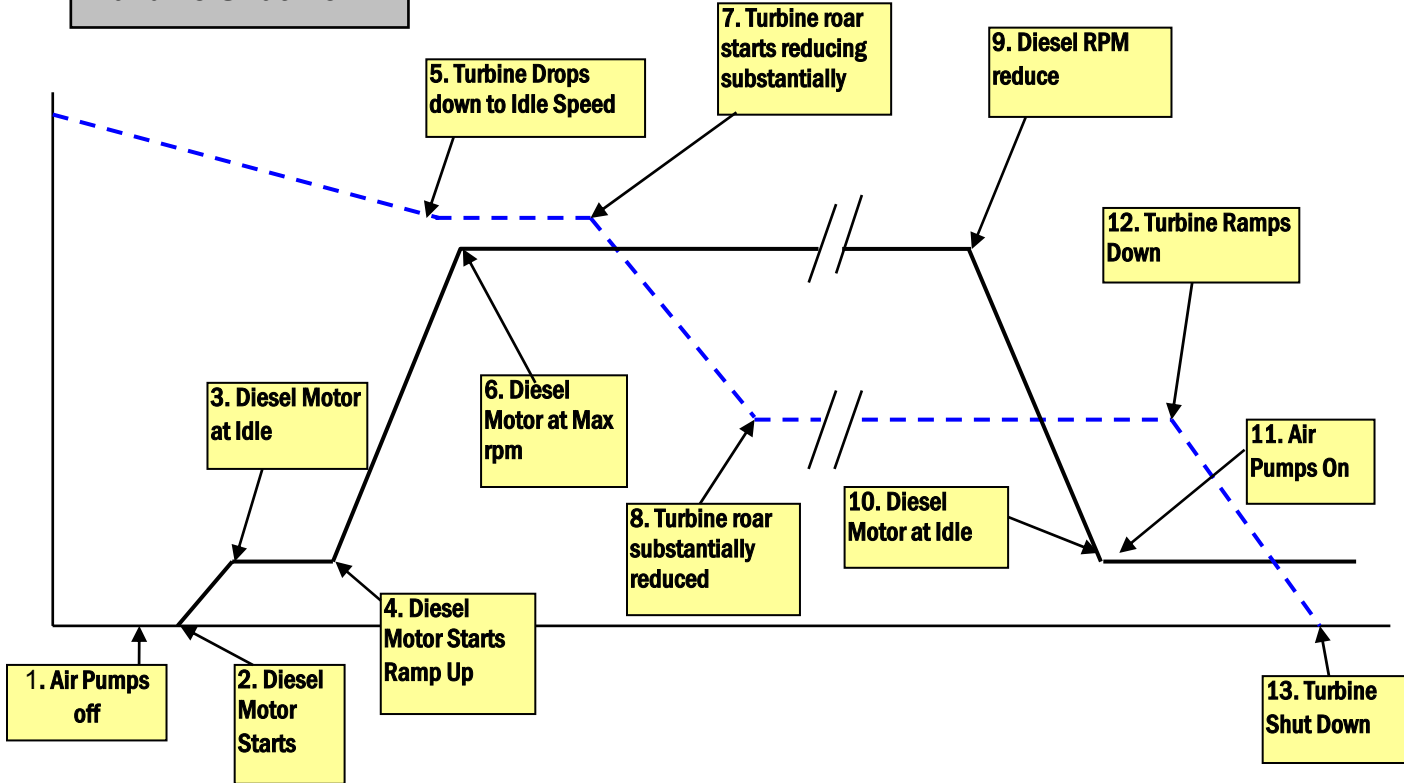

Turbine Operation

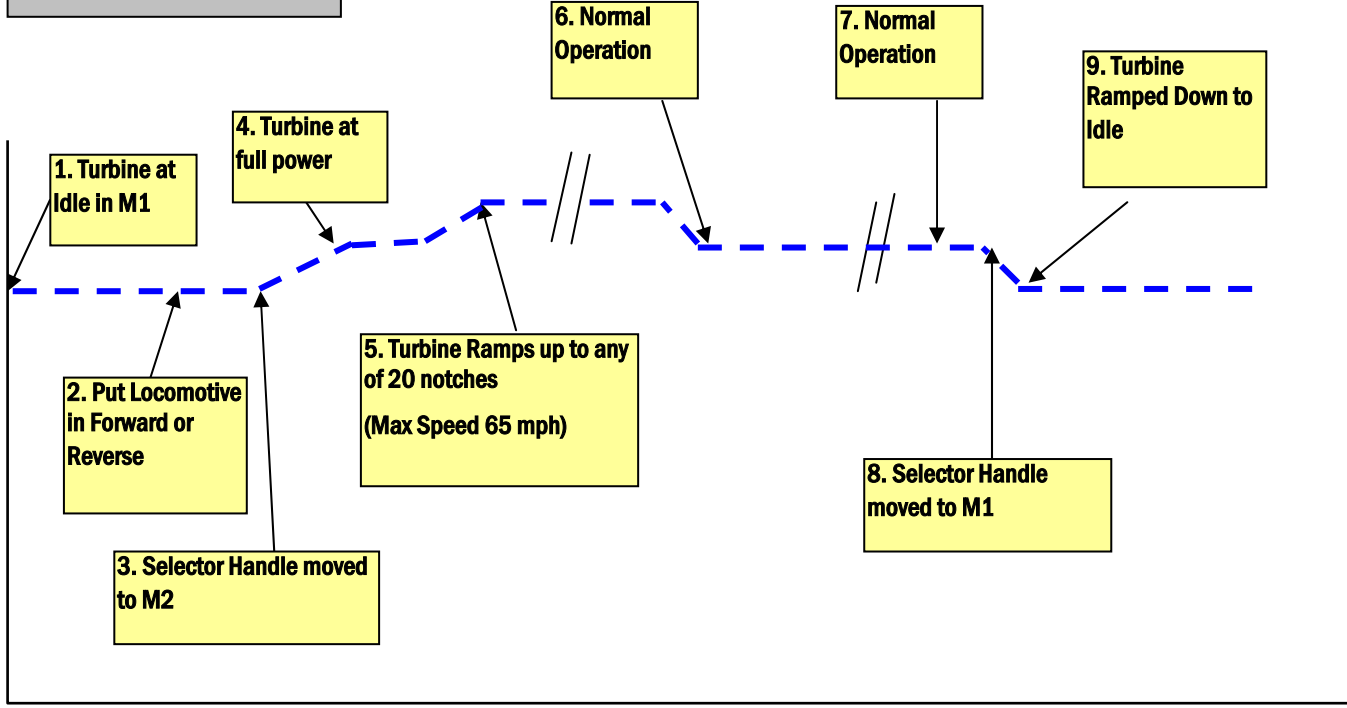

DCC Operation for Quantum Gas Turbine

Introduction

Because the Gas Turbine model required considerable time to bring the turbine on-line or to shut it down, the operation of the transitions between diesel and turbine operation is compressed in time. In the case of shutting down the turbine, a twenty-minute sequence is reduced to a little less than a minute. In addition, there are some conflicting reports about the turbine sound itself. Some witnesses report that the Big Blow only had the deafening whoosh sound and no turbine whine at all. In some of the tapes we heard, there appeared to be a slight turbine whine, especially at idle. Some maintained that there was a whine sound distinctly heard as the turbine was revved up before ignition. We have left it to the operator to decide how the Gas Turbine should sound. We have included both a Whoosh sound and Turbine Whine on separate channels, which can have their volumes adjusted independently. We have set the defaults of the Turbine Whine to be easily heard during the start up and shut down sequence. However, on the main, the Whoosh clearly dominates especially during Sound-of-Power™ periods.

The Gas Turbine will initially start and operate as a standard diesel locomotive except that the speed is limited to 25 smph to model the lower power of the prototype locomotive when operated with the small 250 hp Cummings diesel.

These steps will allow you to start operating your Quantum equipped diesel locomotive immediately using any DCC system that is compatible with the applicable NMRA DCC specifications.

1. Select locomotive number 3.
2. Set your DCC controller to 128 (preferable) or 28 (acceptable) speed step range.
3. Start your locomotive immediately by pressing the F6 DCC function key⁹⁴ to hear the diesel Start Up sounds. Number Board Lights will be on and Mars Light will be Dim. Directional Lighting System (Headlight and Reverse Light) will be off. Use the FL or FO key to turn on the Directional Lighting.
4. Slowly turn up the throttle. Mars Light will strobe. The locomotive default setting is speed control and will maintain the same speed regardless of varying track voltage, grades or other conditions that would normally affect the speed of an HO model locomotive. In addition, the locomotive is pre-calibrated at the factory to move at the speed set by the DCC speed step in scale miles per hour. However, under diesel control, the locomotive will only travel up to 25 smph; any speed setting above 25 smph in Diesel Mode will not increase speed but will cause the motor sounds to be more labored.

When you reduce the throttle to zero, the Gas Turbine will automatically enter Neutral when the locomotive stops. You will hear a Short Air Let-off when the locomotive stops moving and a Long Air Let-off about one second later followed by Air Pumps and other background sounds⁹⁵. The Mars Light will stop pulsing and go Dim and Headlight will go off (if directional lighting had been turned on with the FL key).

The direction of your locomotive will change when you press the direction key on your DCC throttle.

Function Keys

The following table lists features that have been pre-assigned to your DCC function keys. Operation of these keys can be different in the Neutral state (locomotive stopped) and the Motive states (locomotive moving in Forward or Reverse). After you have selected your locomotive, simply press any of the function keys listed below to produce the described effects.

Function Key*	Forward and Reverse	Neutral
F0 or FL or Headlight	Directional Lighting on or off	Directional Lighting on or off
F1	Bell on or off	Bell on or off
F2	Horn or horn with Doppler Effect (see below)	Horn on or off
F3	Coupler Crash/Coupler Fire	Coupler Arm or Coupler Fire
F4	Cooling Fans on or off	Cooling Fans on or off
F5	Dynamic Brake function on or off	Dynamic Brake function on or off
F6	Doppler	Start Up
F7	Squealing Brake/Flanges and Air Brakes	Toggle Diesel or Gas Turbine modes
F8	Audio Mute on or off	Audio Mute on or off
F9	Cruise Control on or off	Shut Down
F10	Short Air Let-off	Short Air Let-off
F11	Short Air Let-off	Short Air Let-off
F12	Mars Light Off/Dim/Pulsing/Off/Dim/Pulsing/etc.	Mars Light Off/Dim/Pulsing/Off/Dim/Pulsing/etc.

* Quantum supports the new NMRA 0-12 function key standard; the old 0-8 standard is not supported.

If you have a DCC command station that supports only the older 0 to 8 function key standard, you will have no way to initiate Shut Down in Neutral with these pre-assigned feature to function key mappings. There is an interim solution to this problem; Swap the features assigned to the F4 and F9 outputs in Neutral by doing the following:

⁹⁴ It does not need to be F6; any function or speed command for a locomotive that is not in Shut Down will activate the locomotive.

⁹⁵ Neutral sounds also include Cooling Fans with Vents opening and closing that turn on and off randomly.

Set CV49 to 6, set CV50 to 1, and set CV53 to 145. Now F4 in Neutral controls Shut Down.
 Set CV49 to 11, set CV50 to 1, and set CV53 to 8. Now F9 in Neutral controls Diesel Cooling Fans.

Changing between Diesel and Gas Turbine Mode

Diesel Mode to Turbine Mode: The Gas Turbine locomotive comes from the factory in Diesel Mode. Because of the limited power from the diesel engine in the prototype, the model will be limited to 25 smph or less in Diesel Mode. To achieve full power from your model for mainline operation, you will need to change to Turbine Mode. There are two ways to do this.

- Press the horn button four times to produce four short horn hoots in Neutral.
- Press the F7 key in Neutral.

The locomotive will go through a complex Turbine Start Up scenario as depicted in the graph below. At the start of the transition to Turbine Mode, the Mars Light will change from Dim to Off. When the transition scenario is completed, the Mars light will change from Off back to Dim⁹⁶.

Turbine Start

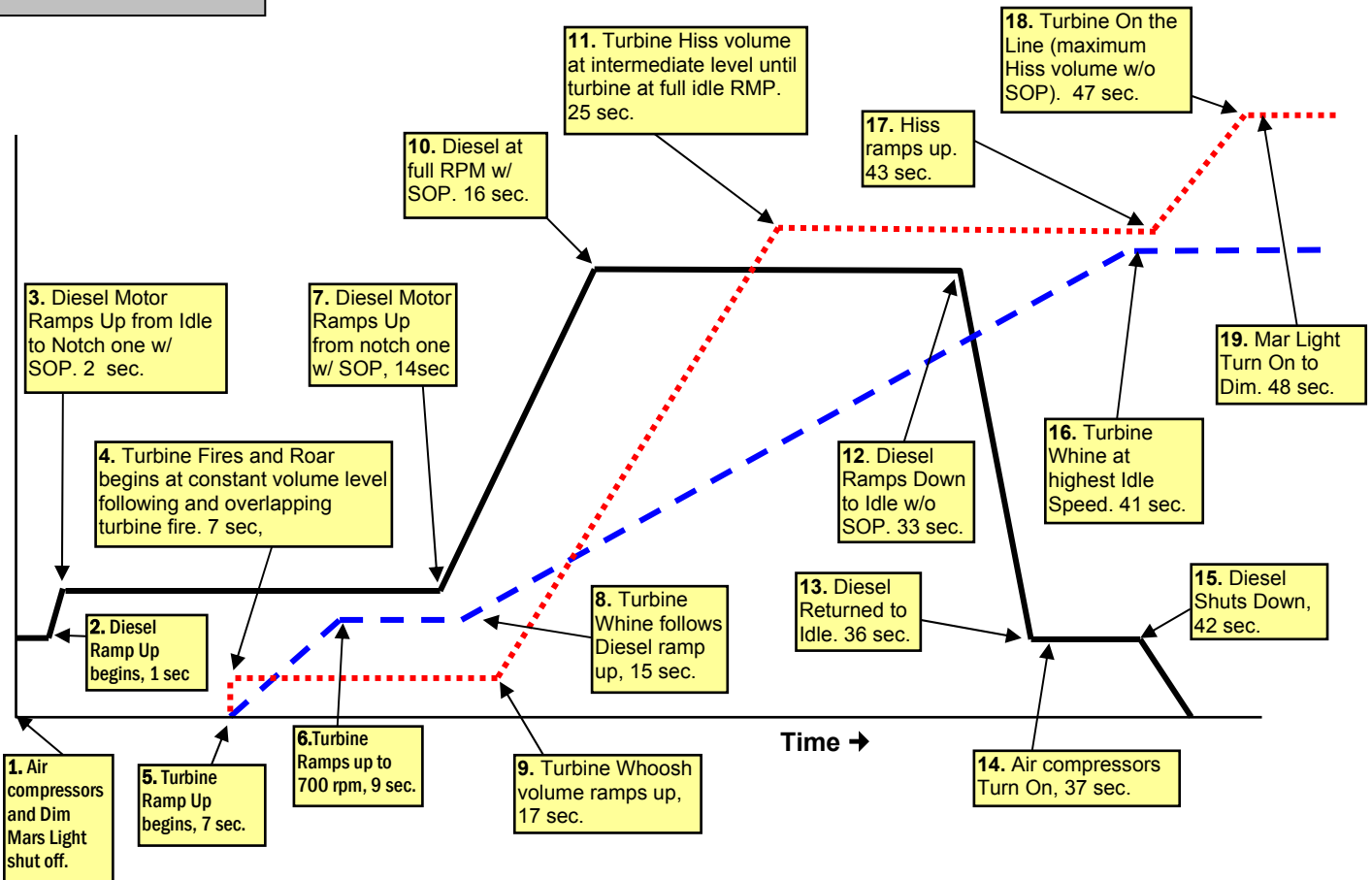

There are three operations shown.

The solid black lines show the volume and rpm operation of the diesel motor.

The dotted blue line with large dashes shows the volume and rpm of the Turbine Whine.

The dotted red line with small dashes shows the volume of the Turbine Whoosh.

The yellow boxes indicate major events in the transition to Turbine Mode. The timing shown in each box indicates the number of seconds since the transition command was sent to start Turbine Mode.

Note: Turbine fire is a distinctive sound that sounds like a giant gas furnace being ignited.

⁹⁶ Mars Light should be in Automatic operation, not "Take Control". See "Automatic Features with "Take Control" "on page 17.

Changing from Turbine to Diesel Mode Diesel Mode to Turbine Mode (F7)

There are two ways to return to Diesel Mode from Turbine Mode.

- Press the horn button four times to produce four short horn hoots in Neutral.
- Press the F7 key in Neutral.

The locomotive will go through a complex Turbine shut down scenario as depicted in the graph below. At the start of the transition to Diesel Mode, the Mars Light will change from Dim to Off. When the transition scenario is completed, the Mars light will change from Off back to Dim.

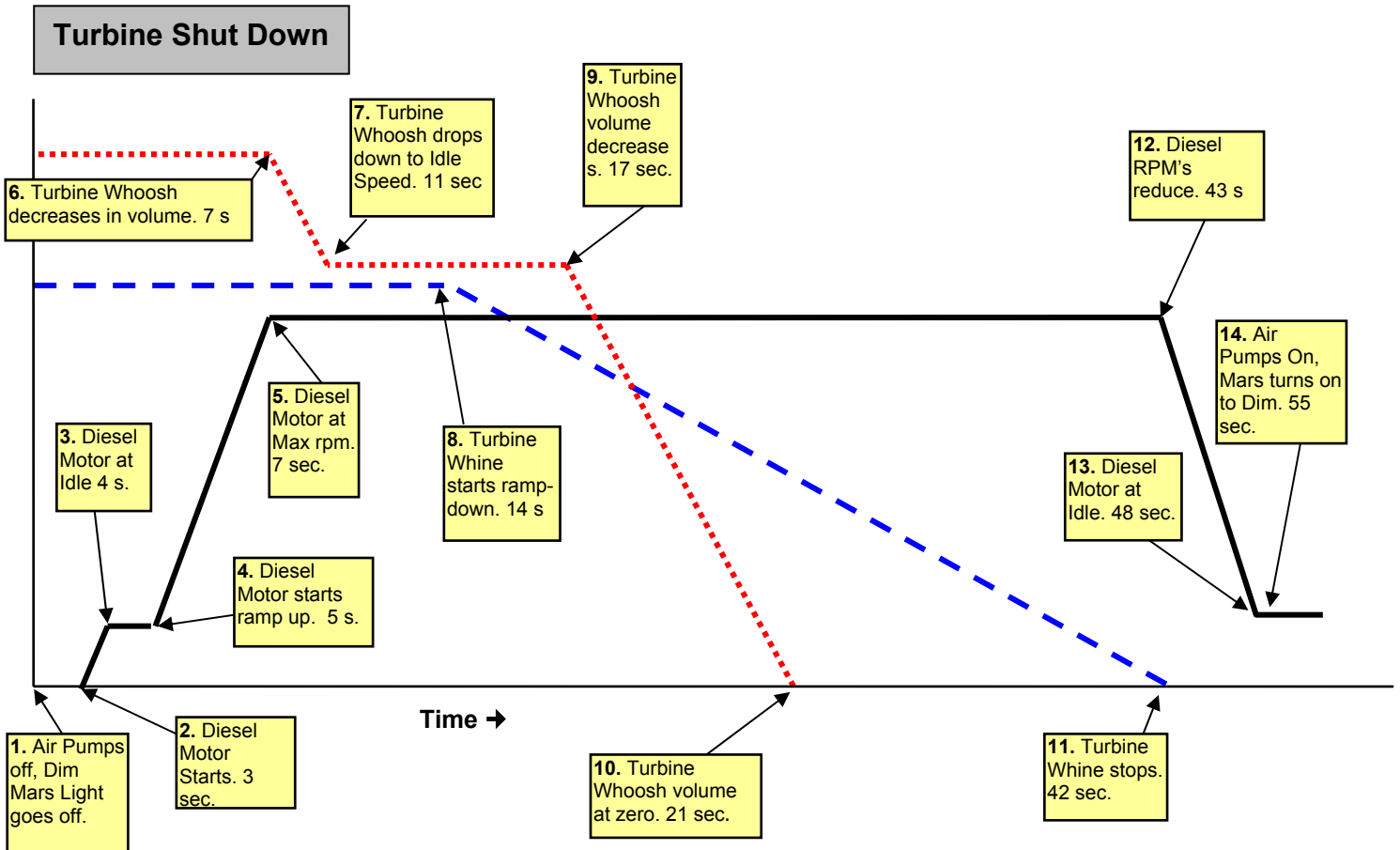

Notes: The following is a list of operational issues when changing between Diesel and Turbine Mode:

- After the Turbine whoosh starts reducing, the Diesel locomotive will continue at maximum RPM for 36 seconds to model the Turbine cool down process.
- Cooling fans and vent opening sounds only occur in Diesel Mode.
- Mars Light, Air Pumps, Cooling Fans and other Neutral Sounds will be suspended during transition from Turbine Mode to Diesel Mode or from Diesel Mode to Turbine Mode, like the prototype.
- If locomotive is in Turbine Mode or Diesel Mode when power is shut off, the engine will power up in the same Mode when power is reapplied.
- If locomotive is at any point in transition from Turbine to Diesel Mode, it will power up in full Diesel Mode when power is reapplied with standard rapid diesel start up sounds.
- If locomotive is in Turbine Mode or in transition from Diesel to Turbine Mode when power is shut off, Turbine sounds will sequence through rapid turn on operation instead of artificially and abruptly producing full Turbine sounds when power is reapplied.
- If the locomotive is in any point in the transition from Diesel Mode to Turbine Mode, and the throttle is turned up to leave Neutral, the locomotive will terminate Diesel/Turbine transition and rapidly enter full Turbine operation in Turbine Mode.

- If the locomotive is at any point in the transition from Turbine Mode to Diesel Mode, and the throttle is turned up to leave Neutral, locomotive will terminate Turbine/Diesel transition and enter Diesel Mode.
- A power cycle or a Software Reset (such as POP 11) in Analog or DCC will not change from Diesel Mode to Turbine Mode or from Turbine Mode to Diesel Mode. A Hardware Reset using the jumper will always return the locomotive to Diesel Mode.
- It is disallowed to move back and forth between Turbine and Diesel Mode when the locomotive is in transition between either Mode. The transition process must be completed before another transition can be initiated.
- Transition from Diesel to Turbine Mode or transition from Turbine to Diesel Mode will only happen in Neutral. Neither the Turbine/Diesel transition by a coded horn (four short horn hoots) or the F7 key will have any affect on changing modes in Forward or Reverse.
- If the locomotive was in Turbine Mode prior to Total Shut Down, the locomotive will first start up in Diesel Mode but will return to Turbine Mode when throttle is increased.
- The coded horn Turbine/Diesel Mode toggle can be disabled in DCC in CV 52.2 bit 1. Enable =1 (default) and Disable =0.

Sound-of-Power™

Your Gas Turbine locomotive will produce labored sounds under acceleration and lighter sounds under deceleration but only if CV 3, or CV 23 and CV 4, or CV 24 are set to non-zero positive values. The level of labored sounds is proportional to the values for these four CV's, and how much the throttle is increased or decreased. Labored sounds will be heard in either Diesel or Turbine Mode.

Diesel Motor RPM: Quantum has eight Diesel Motor throttle “notches” found on most prototype locomotives. As you increase the throttle, you will hear the RPM's increase for every increase in ten speed steps (at 128 speed step setting). Idle is considered Notch 1 and occurs for speed step 0. Notch 2 ranges from 1 to 10, Notch 3 from 11 to 20, Notch 4 from 21 to 30, etc. If your controller has an option to increment or decrement your throttle set setting by ten speed steps, it is very easy and predicable to set your notch value.

Turbine Whine and Whoosh will change with the throttle only slightly over the entire throttle range since the turbine was often run near full RMP at all times. Although the changes in Turbine sound are not as dramatic as changes in diesel RPM's or volume, they are nevertheless quite noticeable.

Directional Lighting Operation (FO or FL or Headlight)

The FL (or FO, or Headlight) key toggles the Directional Headlight/Reverse⁹⁷ on or off.

The defaults for Headlight/Reverse Directional Lights are off. When toggled on, the Directional Lights⁹⁸ operate according to the table below.

Directional Lighting Operation in DCC and Analog with Mars Light Option

	Forward	Neutral from Forward	Reverse	Neutral from Reverse
Headlight	On	Off	Off	Off
Reverse Light	Off	Off	On	Off

Note: Number Board lights and Cab light are on whenever track power is applied and are not under the control of the Quantum System.

Note: Both the tender Reverse Light and locomotive Reverse Light will operate whenever locomotive is in Reverse. These lamps are wired together when tender is plugged in and are not under separate Quantum control.

Coupler and Coupler Crash Sounds (F3)

There are two ways to use the F3 key.

- As your locomotive is about to couple up to a string of cars, press the F3 key to trigger the crashing sound of locomotive coupling. Use the F3 key again as the locomotive moves out to trigger the same sound as the slack is taken up in the cars.
- Use the F3 key in Neutral to produce uncoupling sounds as you disconnect cars over uncoupler magnets. Press the F3 key once to produce the sound of the lift bar and coupling pin being raised. This first press also arms the uncoupling sound effect. Press the F3 key again while moving or in Neutral to trigger the sound of the coupler knuckle opening and air-lines parting.

Horn and Bell Buttons (F2, F1)

Some DCC controllers have separate horn and bell buttons along with function keys assigned to horn and bell operation. The horn is usually assigned to F2. The F2 key behaves differently than using the horn button.

- Pressing the F2 key and releasing it will cause the horn command to come on and stay on, until you press F2 again ⁹⁹.
- Pressing the horn button will send the horn command only as long as you are holding the button down.

⁹⁷ Explicit lighting control features for Headlight, Reverse Light and Mars Light can be assigned to DCC function outputs. (See QSI DCC Reference Manual, version 3)

⁹⁸ Quantum uses constant voltage lighting that is independent of track voltage.

⁹⁹ Since the prototype horn uses compressed air, you will hear the Air Pump sounds turn on after the Horn is operated.

Pressing the F1 key and releasing it will cause the Bell to come on and stay on, until you press F1 again. There is no difference in operation between the bell button and its corresponding function key.

Note: The Veranda Gas Turbine uses a single chime horn¹⁰⁰.

Doppler Operation (F6)

With DCC, you can trigger the Doppler Effect by quickly interrupting the horn signal in the same way it is described under Analog operation. Or you can use the function key (F6) dedicated to the Doppler Effect.

- Start the Horn and/or Bell by pressing and releasing their function keys¹⁰¹.

Press F6 to hear the Doppler shift. A few seconds after the horn button is turned off with the F2 key the locomotive sounds return to normal¹⁰².

Standard Throttle Control, Speed Control and Regulated Throttle Control

There are three ways your locomotive can respond to your throttle.

1. Under **Standard Throttle Control (STC)**, the power to the locomotive is controlled directly by the throttle setting. With STC the speed of the locomotive will change with loading from cars and variations in track voltage.
2. **Speed Control (SC)** uses calibrated internal motor control electronics to maintain the same speed regardless of varying load or track voltage conditions. Under Speed Control, the throttle setting (using 128 speed steps) selects the locomotive's speed in 1 smph (scale miles per hour) increments. If you set the throttle at 35, the model locomotive will go 35 smph on level track or up hill or down hill. If you use 14 or 28 speed steps, you will need to multiple your settings by 9 and 4.5 respectively to compute your scale speed.
3. **Regulated Throttle Control¹⁰³ (RTC)** uses a special Inertial Control method to give the locomotive model the feel of a prototype locomotive. It is the preferred method when multiple heading Quantum locomotives together.

Note: All three types of throttle control are available in either Turbine or Diesel Mode.

Note: The 25 smph limit in Diesel Mode is automatically available in SC and RTC but is not available under STC Operation.

The default is "Speed Control". If you prefer, change the setting in CV 56.4 (see next section).

Cruise Control (F9)

Quantum Cruise Control behaves in much the same way as cruise control on a modern automobile.

- Press F9 and hear two short toots when Cruise Control is toggled on
- Press F9 and hear one short toot when Cruise Control is toggled off.

When Cruise Control is on, the locomotive will continue at its present speed regardless of grades, changes in load, or tight curves. Turning the throttle up or down will not affect locomotive speed, but will cause Sound-of-Power chuffing labor sounds to change in direct proportion to the throttle's movement from the initial setting (where Cruise Control was turned on). You can increase the laboring motor sounds in Cruise Control as a train climbs a grade or decrease the Sound-of-Power effects as the train moves down the grade.

Return the throttle to its initial setting to avoid acceleration or deceleration when Cruise Control is toggled off.

Note: Cruise Control is only available in Regulated Throttle Control or Speed Control. In Standard Throttle Control, F9 will produce in a Short Air Let-off.

Note: Cruise Control is automatically turned off when the speed step is reduced to zero or track power is turned off.

Squealing Brake and Flange Sounds (F7)

- Quantum provides automatic brake squeal as a locomotive slows to a stop. The operator can also control squealing sounds for continuous and variable brake sounds for protracted stops or to simulate the sounds of squealing wheel flanges on curved track.
- Squealing Brakes come on automatically when the speed is reduced from high-speed travel (over 35 smph) to less than 10 smph.
- Pressing the F7 key when the locomotive is moving at any speed will manually activate Squealing Brake sounds, and repeated pressings while the Squealing Brake sounds are occurring will continue the sounds uninterrupted.

Note: If you slow the locomotive too quickly, the brake sounds will terminate abruptly when the locomotive stops and enters Neutral.

Note: The Gas Turbine does not have an Air Brake effect using the F7 key that is standard on later Quantum locomotives that actually reduces the speed of the locomotive.

¹⁰⁰ Some commercial videotapes of the Gas Turbine have dubbed a multi-chime horn in for sound effects and do not represent the actual locomotive horn.

¹⁰¹ If you do not turn on either Horn or Bell, the Doppler shift will still occur but will be less dramatic.

¹⁰² If the Bell was on, it will shut off prior to sounds returning to normal.

¹⁰³ RTC maintains locomotive speed through minor impediments such as misaligned track joints, rough switches, tight curves, etc, but also allows gradual power equalization when locomotives are used in concert.

Dynamic Brakes (F5)

The prototype Gas Turbine locomotive has dynamic brakes that cause the train to slow down by using the traction motors in generator mode. This helps dissipate the energy of a moving prototype train by converting it to electrical power, which is then applied to a large air-cooled resistor load in the locomotive.

- Pressing the F5 key in Forward or Reverse will set the locomotive Diesel Motor or Turbine sound to idle at the lowest Sound of Power setting and turn on the powerful Dynamic Brake cooling fans.
- Pressing the F5 key in Neutral and Disconnect (see Shut Down, next page) will turn on the Dynamic Brake Fans while Diesel Motor sounds remain at idle.

The Dynamic Brake function automatically turns off when entering or leaving Neutral, or the speed of the locomotive drops below 7 smph¹⁰⁴, or if the throttle is turned up. The Dynamic Brakes cannot be turned on in Forward or Reverse unless the locomotive is traveling over 8 smph.

Note: Dynamic Brakes do not increase the deceleration rate specified by CV 4 and CV 24.

Note: Dynamic Brakes sounds will be barely audible over the Turbine roar in Turbine Mode.

Automatic Features with “Take Control” Operation

The Quantum System allows the operator to take control of certain automatic features by using their associated function key. Once you “Take Control”, the features will no longer have automatic operation and you will control their operation and their state with their function key commands. Automatic and Take Control operations are described in the table below.

Gas Turbine Locomotive “Take Control” Operation

	Automatic Operation			Take Control	
	Forward	Reverse	Neutral	Function Key	Operation
Vents & Cooling Fans	Non-operating	Non-operating	On and off at random times	F4	Toggles Vents/Cooling Fans operation between on or off.
Mars Light	Strobing	Dim	Dim	F12	Mars Light Off/Dim/Pulsing/ Off/Dim/Pulsing/ etc.

Note: In Neutral, Mars is set at Dim to conform to general Rail Safety regulation Rule 17. In Forward and Reverse, Mars is pulsing.

- Take Control of Automatic Cooling Fans with the F4 key to stop Automatic Control and select whether the Cooling Fans are on or off.
- Take Control of the Pulsing Mars Light with the F12 key to change the Mars Light state progressively through states of Off, Dim, Pulsing, etc. each time the F12 key is pressed.

Regardless of the state of the automatic fans (on or off), if you press the F4 key, the Cooling Fans will be set to on if the F4 key is “1” and off if the F4 key is “0” and Automatic Control will be disabled. Thereafter, the fans will respond only to the state of the F4 function.

Note: Automatic Control will be restored if the power is shut down and reapplied or if the F6 Start Up key is double pressed in Neutral (see the description of Start Up at the bottom of this page).

Note: If Mars Light is under DCC “Take Control” operation, the Mars light will not provide reliable information of the beginning of the Turbine Shut Down operation but will provide information about the beginning of Turbine Start Up operation. Turbine Start Up/Shut Down will reset all “Take Control” features to “Automatic Operation”.

Three Stages of Shut Down: 1. Disconnect, 2. Standby, 3. Total Shut Down (F9)

Locomotive Shut Down has three distinct stages that you can control. Each stage is entered by double pressing the F9 key¹⁰⁵. If the locomotive is in Turbine Mode, any shut down operation will automatically return it in Diesel Mode prior to shut down operation.

Stage One: Disconnect

- Double press the F9 key in Neutral to enter Disconnect. You will hear a Long Air Let-off.
- To leave Disconnect, either double press the F6 Start Up key, as described in the Start Up section or double press the F9 key again to reach the next stage of Shut Down: Standby.

If you double press the F9 key in Neutral, the electric motor drive will be disabled. Once you hear the Long Air Let-off, the DCC throttle can be moved up and down without the locomotive moving. As the throttle is moved up or down, you will hear the Diesel Motor rev up and down in proportion to the throttle setting.

Note: All function keys are operable in Disconnect.

¹⁰⁴ Dynamic Brakes on prototype locomotives are less effective and are seldom used at low speeds.

¹⁰⁵ Double-pressing ensures that Shut Down stages are not entered or exited accidentally. Double-pressing is defined as two F9 commands sent within two seconds. Note that the F9 key may have to be pressed three times, due to the DCC command station and locomotive having different initial states for F9.

Note: You can also turn on the Dynamic Brakes (see description of Dynamic Brakes below) to create Sound-of-Power as the throttle is moved up and down. Engineers on prototype diesels use dynamic brakes to load the motor-generator to test its output efficiency while the locomotive remains stationary.

Stage Two: Standby

- Double press the F9 key while in Disconnect to enter Standby. You will hear a Long Air Let-off followed by a special “Low Idle” sound. The Directional Lighting and Mars Light will shut down. The motor will remain disconnected, while the Air Pumps, automatic Cooling Fan operation and Number Board Lights will continue to operate. In Standby, the locomotive will not respond to throttle or function keys. The two exceptions are the F6 Start Up Key and the F8 Mute Key (described below).
- To leave Standby, either double press the F6 Start Up Key, as described in the Start Up section, or double press the F9 key again to reach the final stage of Shut Down: Total Shut Down.

Note: Standby is ideal for leaving your locomotive running on a siding. Besides hearing the Low Idle diesel motor sounds, the locomotive will not respond to accidentally changing the throttle setting or pressing the function keys.

Stage Three: Total Shut Down

- Double press the F9 in Standby to enter Total Shut Down. You will hear a Long Air Let-off.
- To leave Total Shut Down, double press the F6 key.

The Air Pumps will turn off, followed by the sounds of the Cooling Fans shutting off, the louvers closing and the Diesel Motor shutting down. A few seconds later you will hear the engineer’s door open and then shut. In Total Shut Down, the locomotive will not respond to throttle or function keys. The one exception is the F6 Start Up Key (described below).

Note: Total Shut Down allows the operator to take the locomotive “off line” (turn off sounds, lights, ignore throttle settings and function commands) independent of the operating session; that is, the locomotive will still be “off line” when power is reapplied for the next operating session, irrespective of whether this next session is Analog (conventional DC) or DCC.

Note: If power is turned off at any stage of Shut Down (Disconnect, Standby or Total Shut Down) or during a Shut Down procedure, the locomotive will remember the last Shut Down stage it was at during power down, and the locomotive will power up in the same stage. If Start Up is initiated during any of the above Shut Down procedures, Shut Down is aborted, and locomotive will return to normal operation.

Start Up (F6)

If Gas Turbine locomotive is in any stage of Shut Down, you can return it to normal operation by double pressing¹⁰⁶ the F6 key. Start Up will be different for each stage of Shut Down, but all will start up with a Long Air Let-off and will enter normal operation.

Start Up from Disconnect: If you double press the F6 key in Disconnect, the diesel locomotive will produce a Long Air Let-off, Dynamic Brakes will shut off (if on) and the locomotive will enter normal operation.

Start Up from Standby: If you double press the F6 key in Standby, the diesel locomotive will produce a Long Air Let-off, the Diesel Motor sound will change from the special Low Idle to regular Idle, and the locomotive will enter normal operation.

Start Up from Total Shut Down: If you double press the F6 key in Total Shut Down, the diesel locomotive will produce a Long Air Let-off, you will hear the engineer’s door opening and closing, and see the Mars Light turn on steady. These actions are followed by the sounds of vents opening, the Diesel Motor starting up, the Air Pumps starting up, followed by a Long Air Let-off and the locomotive entering normal operation.

Note: During the Start Up procedure, none of the DCC function keys are active. If the throttle is turned up from zero during any of the above Start Up procedures, the Start Up procedure will abort and the locomotive will enter normal operation.

Note: Whenever a Start Up command is sent, regardless of whether the locomotive is in Shut Down or operating normally (in Neutral), the Quantum System will automatically restore all Automatic Control.

Mute (F8)

The Quantum System allows you to reduce the System Volume to a lower level or increase it back to its original setting using the F8 function key. This capability is useful when you need to reduce the sound to engage in a conversation or to answer the phone. If you have many trains operating at once, you can reduce the volume on all those that are running in the background of the layout and increase the volume of the closest locomotive¹⁰⁷.

- Press the F8 key in Neutral or Forward/Reverse to gradually decrease or increase the locomotive’s volume.

Note: Mute state is not maintained if power is turned off and then turned back on; the locomotive will return to full volume setting.

Note: Mute Volume can be programmed in CV 51.1.

Function Key Operation in Neutral

Some function keys used in Forward and Reverse will have different effects when used in Neutral:

¹⁰⁶ Double-pressing ensures that Start Up is not entered accidentally. Double-pressing is defined as two F6 commands sent within two seconds. Note that the F6 key may have to be pressed three times, due to the DCC command station and locomotive having different initial states for F6.

¹⁰⁷ The Gas Turbine Mute feature changes the volume immediately unlike later model Quantum locomotives that changes the sound gradually over a few seconds.

- The F7 key produces Squealing Brake Sounds for a moving locomotive but produces Diesel/Turbine transitions in Neutral.
- Pressing F6 results in Doppler shift for a moving locomotive but activates Start Up in Neutral.
- Pressing F9 produces Cruise Control (under RTC and STC) in a moving locomotive but activates Shut Down in Neutral.

Note: The Horn, Bell, Doppler Shift, Squealing Brake and Neutral sounds are described in detail on pages 23-24, in the Quantum System Sounds section of this manual.

DCC Programming for the Gas Turbine

Most DCC command stations currently available will program Quantum equipped locomotives in Service Mode¹⁰⁸ on a programming track or Operations (Ops) Mode on the main track. In Service Mode, your locomotive (if queried) will report back CV values to your command station. In Ops Mode, reports are verbal using the locomotive sound system.

Changing the System Volume Electronically in CV 51.0

You can change the volume either manually (as described in the *Special Operation and Troubleshooting* section) or electronically using QSI CV 51.0 in DCC¹⁰⁹. To change volume in Service or Ops Mode, do the following:

- Set CV 49 to 0.¹¹⁰
- Enter the System Volume in CV 51. The System Volume can be set to any value between 0 (no sound) and 127 (100%). The default System Volume is 127.

Note: When you change the System Volume in Ops Mode, you will immediately notice the change in volume.

Changing the Mute Volume Electronically in CV 51.1

To change the Mute Volume in Service or Ops Mode, do the following:

- Set CV 49 to 1.
- Enter the Mute Volume in CV 51. The System Volume can be set to any value between 0 (no sound) and 63 (100%). The default Mute Volume is 0.

Note: When you change the Mute Volume in Ops Mode, and the locomotive is muted, you will immediately notice the change in Mute Volume.

Note: The Mute Volume level will be the smaller of the Mute Volume setting or one-half the current System Volume. In other words, the Mute Volume will never be more than one half of the System Volume.

Enable/Disable Doppler Shift from Whistle Signal Interrupt and Enable/Disable Turbine/Diesel Transition from Coded Horn (CV 51.2)

- Set CV 49 to 2.
- Set CV 51 to the value indicated in the table below. An “X” in the table indicates that the feature will be enabled. The default is 3 (both features are enabled).

Doppler from Horn Signal	Turbine Transition from Coded Horn	Decimal Value	Binary Value	Hex Value
		0	00000000	00
X		1	00000001	01
	X	2	00000010	02
X	X	3	00000011	03

Changing Individual Sound Volumes (CV 52.X¹¹¹)

To change the volume of individual sounds listed in the table below do the following:

- Set CV 49 to the Primary Index for the individual sound from the table below.
- Enter Volume level in CV 52 as follows: “0” = No sound, “1 – 15” = Sets volume from the lowest value at “1”, the highest volume at “15”. The volume levels are in 2db increments.

¹⁰⁸ If your DCC command station will not program in Service Mode, check with the command station manufacturer; some companies will give you a free upgrade. Also, see *Special Operation and Troubleshooting* on page 25.

¹⁰⁹ System Volume changes in DCC also apply to Analog and vice-versa.

¹¹⁰ In Ops Mode, you will hear the value spoken out when changing the value of a CV.

¹¹¹ ‘X’ refers to the value in column 1 of the table, the Primary Index number put into CV 49.

Primary Index entered into CV 49	Sound	Default
0	Horn	11
8	Bell	13
10	Diesel Motor	7
13	Turbine Whoosh	12
15	Turbine Whine	8
16	Air Pump	10
19	Diesel Motor Cooling Fans and Vents	8
21	Long Air Let-off	11
22	Short Air Let-off	11
24	Squealing Brakes	11
28	Dynamic Brakes	10
34	Coupler Sounds	11

Standard Throttle Control, Speed Control and Regulated Throttle Control Options (CV 56.4)

- Set CV 49 to 4.
- Set CV 56 to: 0 for Standard Throttle Control, 1 for Speed Control and 2 for Regulated Throttle Control. The default is 1.

Note: CV 2, CV 5 and speed tables are available for Standard and Regulated Throttle Control¹¹² but inactive for Speed Control. See DCC Quantum Reference Manual (Version 3).

Reset All¹¹³ CV's to Factory Default Values (CV 56.128.255)

Note: This does not affect Analog settings, except for volumes.

- Set CV 49 to 128.
- Set CV 50 to 255.

Set CV 56 to 113¹¹⁴. In Ops mode, you will hear 3 hoots when reset is completed.

Special Procedure for Short or Extended Address Programming (CV 56.129)

If you cannot program your Short or Extended ID number in Service Mode and your DCC command station prevents you from setting either of these addresses in Ops Mode (using CV 1, or CV 17 and CV 18) use the following alternative procedures to program your locomotive's ID's.

Alternate Procedure for Entering Short (Primary) Address in CV 56.129.1 in Ops Mode

- Set CV 49 to 129.
- Set CV 50 to 1.
- Set CV 56 to your Short Address (1 or 2 digits). Hear the address spoken back (CV 1 = XX).
- If necessary, set CV 29, bit 5 to '0' (or set CV 29 to 6 which is factory default) to enable your new Primary Address.

Procedure for Entering your Locomotive's Long (Extended) Address in CV 56.129 in Ops Mode.

- Determine the value of CV 17 and CV 18 for your Challenger extended address from table below or follow instructions in CV 17 and CV 18 in the *DCC Quantum Reference Manual* to calculate a different ID number.
- Set CV 49 to 129.
- Set CV 50 to 17.
- Enter CV 17 into CV 56. There will be no verbal response.
- Set CV 50 to 18.
- Enter CV 18 into CV 56. Hear the new full address spoken out.
- Change CV 29, bit 5 to "1" (or set CV 29 to 34¹¹⁵) to allow operation with your new extended address.

¹¹² Regardless of the value of CV 2, RTC has a minimum speed of 1 smph at speed step 1.

¹¹³ Consult the DCC Reference manual to learn how to reset different groups of CV's.

¹¹⁴ "113" is QSI's Manufacturer's ID Number assigned by the NMRA.

¹¹⁵ This leaves all settings at factory default, but changes the ID to extended type.

Loco Number	CV 17 (Dec)	CV 18 (Dec)	CV 17 (Hex)	CV 18 (Hex)	CV 17 (Binary)	CV 18 (Binary)
61	192	61	C0	3D	11000000	00111101
64	192	64	C0	40	11000000	01000000
66	192	66	C0	42	11000000	01000010
71	192	71	C0	47	11000000	01000111
73	192	73	C0	49	11000000	01001001
75	192	75	C0	4B	11000000	01001011

Note: When you select your locomotive with a two digit ID as an extended address, you may need to enter leading zeros to distinguish it from a Primary (short) ID on some command stations (e.g. 0062 instead of 62).

Disable/Enable Verbal Announcements (CV 62)

In Ops Mode, the Quantum System will automatically speak out the value of the CV that you enter.

To disable set CV 62 to 0¹¹⁶; to enable set CV 62 to 1¹¹⁷. Default is "Enabled".

CV Inquiry with Verbal Feedback in Ops Mode (CV 64)¹¹⁸

To inquire about the current value of any CV through Verbal Feedback in Ops Mode:

- With locomotive in Neutral, Set CV 64 to the CV you wish to query. Hear the verbal message "CV 'X' equals 'Y'", where 'X' is the CV number and 'Y' is the value.

Note: If the CV has a Primary Index such as QSI CV nn.pp (where nn is the CV number and pp is the Primary Index), set CV 49 to pp before you set CV 64 to nn. For example, if you want to inquire about the Diesel Motor Volume, which is CV 52.10, set CV 49 to 10 and set CV 64 to 52. You will hear, "CV five two point one zero equals 'Y' (where 'Y' is the current volume setting). If the CV has both a Primary and Secondary Index, such as CV nn.pp.ss where ss is the Secondary Index, set CV 50 to ss in addition to setting CV 49 to pp before you set CV 64 to nn. .

Note: If you enter either '17' or '18' in CV 64, you will hear the full one to four digit Extended Address ID number spoken out.

NMRA Configuration Values (CV 29)							
Each bit in CV 29 controls some basic operational settings for DCC decoders, including Extended Addressing, Speed Table Enable, Power Source Conversion, Lighting Operation, Locomotive Direction, and others.							
The following table provides some of the more common values for CV 29 for the features indicated. Default is 6.							
Extended Addressing	Speed Tables	Power Conversion	28/128 speed Steps	Reversal Direction	Decimal Value	Binary Value	Hex Value
			X		2	00000010	0x2
		X	X		6	00000110	0x6
	X		X		18	00010010	0x12
	X	X	X		22	00010110	0x16
X			X		34	00100010	0x22
X		X	X		38	00100110	0x26
X	X		X		50	00110010	0x32
X	X	X	X		54	00110110	0x36
			X	X	3	00000011	3
		X	X	X	7	00000111	7
	X		X	X	19	00010011	13
	X	X	X	X	23	00010111	17
X			X	X	35	00100011	23
X		X	X	X	39	00100111	27
X	X		X	X	51	00110011	33
X	X	X	X	X	55	00110111	37

¹¹⁶ You will not hear "CV 62 equals 0".

¹¹⁷ You will hear "CV 62 equals 1".

¹¹⁸ This option is not disabled by CV 62.

Special Operation and Troubleshooting

With some Command Stations, using the horn button to activate the Horn, and, while this button is held down, activating the F6 Doppler key, will cause the Horn to shut off instead of causing a Doppler shift effect.

We have experienced intermittent and independent horn signal interruption with some DCC command stations, causing unexpected Doppler shifts. If this happens frequently, you can disable the Horn Triggered Doppler (CV 51.2).

Manual Volume Adjustment (Analog and DCC)

To adjust the volume by hand:

- Locate the removable hatch on the top of your Lionel Gas Turbine locomotive and remove it using your fingernail. It is located in the center of the roof and is held in place magnetically. Manual Volume Control (blue potentiometer) is located towards the front with the Reset Jumper directly behind.
- Use a small screwdriver to turn the potentiometer clockwise to increase volume or turn it counterclockwise to decrease the volume.

Note: Volume can also be adjusted digitally using the programming methods described in the programming sections of this manual. However, if you turn the volume down using the Manual Volume Control, you will not be able to increase the volume using programming above the level set by the potentiometer.

Using the Quantum Reset Jumper to Return Your Locomotive to Factory Default Values (Analog and DCC)

In case your locomotive's sound and control system misbehaves and turning the power off and back on does not return it to normal operation, you can reset your locomotive to original factory values.

- Turn off the power.
- Use small needle nose pliers to pull the jumper up and out.
- Reapply power; after a few seconds you hear three Horn hoots in quick succession.
- Turn power off, reinstall the jumper. The locomotive has now been returned to original factory defaults for all DCC and Analog values.

Program Track Operation (DCC)

Your locomotive conforms to NMRA standards for program track operation. However, the Quantum System requires more current to operate than standard DCC decoders and may not respond to the limited program track power from some command stations. If you are unable to program in Service Mode on your program track, all CV's in your locomotive can be programmed in Ops Mode. You can also purchase from Tony's Train Exchange®¹¹⁹, a simple, inexpensive power booster (PowerPak™ by DCC Specialties) that will allow you to program on the program track with any DCC command station.

Reasons why Your Locomotive is Silent or will not Start (Analog and DCC)

In case your locomotive remains silent after power up and turning the power off for 15 seconds does not return it to normal operation, try the following suggestions to bring your locomotive back to normal sound operation.

- Make sure the locomotive has not been Muted with the F8 key.
- Check to see if your volume potentiometer or digital sound has been turned all the way down.
- You may have shut your locomotive down in DCC using the F9 key, **which will also shut it down in Analog**. Go back to DCC operation and start your locomotive with the F6 key. Once started, you can return to DC or DCC operation.

If the above methods do not start your locomotive, use the jumper to reset your locomotive to factory default values as described above.

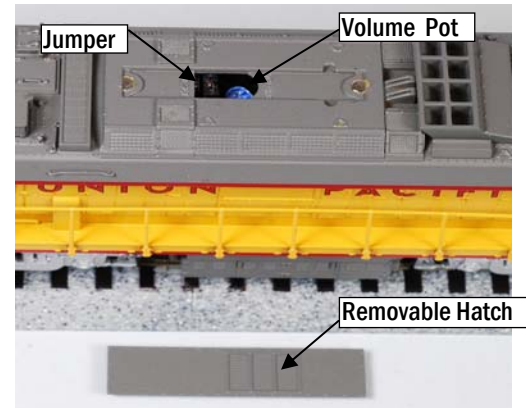

¹¹⁹ Tony's Train Exchange; 1-800-978-3427; www.tonystrains.com.

Appendix III A

Recommended DCC Command Stations

Command Station	Recommended	Will Support Service Mode w/ Quantum	Comments ¹²⁰
NCE™	Yes	Yes (See Comments)	Horn and Bell buttons are available but bell button assigned to F3 (see QSI CV 37 example). Newer NCEs apparently support programming track but older command stations do not. Programming on the main is easy and straightforward. NCE currently only supports F0-F8 Function Keys.
Wangrow™	Yes	No	Horn and Bell buttons are available but bell button assigned to F3 (see QSI CV 37 example). No Service Mode but programming on the main is easy and straightforward.
Digitrax™	Yes	Yes	<p>F0 = Lights, F1 = Bell, F2 = Horn. DT300 will operate in Service mode but will not read back value. Long address is automated with the DT300 and DT400 throttles, which properly writes CVs 18, 17, and 29. Click to the 4-digit mode, set address, and answer yes to the enable 4 digit address prompt. It also automatically resets CV29 if you return to 2-digit address.</p> <p>An exception is the obsolete DT100 throttle, which will only program Quantum in Ops Mode. Use QSI CV 56.129 to program either CV 1 or CV 17/18. Note that the DT100 only programs in hex, except for addresses, which are in decimal. This makes it easy to enter address in Ops mode.</p> <p>We have qualified the following Digitrax systems with Quantum (all support F0-F12): Super Chief with DT400 Zephyr with DT400 DCS100 with DT400 Chief with DT400</p> <p>See Digitrax for more information on QSI compatibility at www.digitrax.com.</p>
MRC™	Yes	No	MRC does not provide a separate programming function. All programming is done in Ops mode with no acknowledgement feedback. A resistor is included to limit current for a Programming Track, which may limit the current below the allowable level for Quantum programming. For the Quantum system, the resistor may be left out. For other decodes, the user should follow the MRC instructions.
Lenz™ LZ100, LV200, LZV100	Yes	Yes (See Comments)	F0 = Lights, F1 = Bell, F2 = Horn. Lenz will program in Service mode providing that a suitable resistor is added in series to the Programming Track (LV100 requires 20 ohms and LV200 requires 10 ohms). Note that CV 1, 17 and 18 cannot be programmed on the main in the standard way (see QSI CV 56.29 for alternative way to program ID

¹²⁰ Many comments and opinions regarding operation with different command stations are the result of user's letters to QSI or comments on various railroad web forums. QSI is not responsible for the accuracy of these comments, which are included here only as a starting point for the customer to verify to his own satisfaction the compatibility of these products for use with the QSI Quantum System.

			numbers). Newer Lenz does support F0-F12 Function Keys.
Atlas TM	Yes	Yes (See Comments)	Early models of the Atlas command station had some problems with programming. Reports from Atlas on their recent versions indicate no problems. Limited number of function keys available.
CVP TM	Yes	Yes	EZ DCC. Works with wireless hand held throttle as well as standard command station.
Zimo TM	Yes	Yes	All products work with Quantum.

Appendix III B

Programming a Long Address on Digitrax

Select the Loco's Short Address (Usually 3)

- Press "Loco" then "3" then "Enter".

Program "On the main" the new Long Address.

- Press "PROG" until "Po" and the Loco's address is shown on the LCD.
- Press right turn knob down until it reads "ad4 = ???"
- Type in desired four-digit address and press "Enter". Loco verbally responds with "CV 18 = XXXX" where XXXX is the four digit address.

Once the long address is programmed, you must enable the locomotive to use it.

Enable the Long Address.

- Next, press the right turn knob until it reads "ad2 = 000"
- Scroll with left knob until you get to "029 = ???"; turn right knob until readout displays "029 = 034"; press Enter, locomotive says "CV 29 = 34".
- Press "Exit" to leave program mode.

Select Loco with the new Long Address.

- Press "LOCO" and enter new long address to run locomotive.

Returning to the Short Address

Select the Loco's Long Address (The value you programmed above)

- Press "Loco" then the Long Address then "Enter".

Program "On the main" to Enable the Short Address.

- Press "PROG" until "Po" and the Loco's address is shown on the LCD.
- Scroll with left knob until you get "CV29 = ???"; scroll with right knob until you get "029 = 002"; press Enter; locomotive verbally responds with "CV 29 = 2".
- Press "Exit" to leave program mode.

Select Loco with the Short Address.

- Press "LOCO" and enter Short Address to run locomotive.

Appendix III C

Programming a Long Address on North Coast Engineering (NCE)

Select the Loco's Short Address (Usually 3)

- Press "Loco" then "3" then "ENTER".

Program "On the main" the new Long Address.

- Press the "Program" button. Display reads "Program on Main".
- Press "ENTER".
- Display shows current "003" I.D. on the display.....Press "ENTER"
- Press 1 for Address. Display shows "Set ADDR"
- Press "1" to set Long Address.
- Enter four-digit address. Press "Enter" Hear "CV 18 equals XXXX" where XXXX is the four digit address you entered.
- You are now back in Run Mode. Select loco 3. Press "ENTER".
- Once the long address is programmed, you must enable the locomotive to use it.

Enable the Long Address.

- Press the "Program" button. Display reads "Program on Main".
- Press "ENTER".
- Display shows current 003 I.D. on the display. Press "ENTER"
- Press "3" for Configuration. Display shows "ENTER = NORM 1=REV".
- Progress through and set each variable until you reach "ADDRESS?".
- Enter "1" for "LONG" address. This enables using the long address.
- Leave Ops Mode Programming by pressing the red "Emergency Stop" button.
- Select locomotives long address and operate.

You are now out of program mode and have completed "the Long Address" sequence.

Returning to the Short Address

Select the Loco's Long Address (The value you programmed above)

- Press "Loco" then enter the Loco's Long Address (The value you programmed above) then press "Enter".

Program "On the main" to Enable the Short Address.

- Press the "Program" button. Display reads, "Program on Main".
- Press "ENTER"
- Display shows current Long Address I.D. on the display. Press "Enter"

- Press “3” for Configuration. Display shows “ENTER=NORM 1=REV”.
- Progress through each variable until you reach “ADDRESS?”.
- Press “ENTER” for “SHORT” address. This enables using the short address.
- Leave Ops Mode Programming by pressing the red “Emergency Stop” button.
- Select locomotives short address and operate.

The above procedure was evaluated with an upgraded¹²¹ NEC POWER PRO series of DCC command stations. If the above procedure does not work properly, contact NEC to see if they can upgrade your software.

¹²¹ NCE Software Version 1.3, December, 21, 2004.

Appendix IV

DCC Troubleshooting

Operations Mode

My headlight does not come on when I start my locomotive but mysteriously comes on whenever I blow the horn or turn on the bell. Also, if I try to turn on the headlight, it requires two pressings for the F0 or FL key.	Pressing the horn or toggling the bell will cause your command station to send out a Function Group One command, which contains the lighting information. Not all command stations automatically send this information unless FL, F1, F2, F3 or F4 is pressed. Regarding turning on the lighting with the F0 key, the state for the light may already be on at the base station but not sent. When you press the F0 key, it toggles the lights off and sends that command. It takes a second press of the F0 key to send another command to turn on the lights.
My brakes, bell, air release, or other sounds comes on sometimes for no apparent reason while operating my locomotive.	See above. Some functions may already be turned on but not sent. When you request any function, the entire function group that contains that function will be sent and this may trigger other features already enabled within that group. Hence, you might request the light be turned on and hear squealing brakes or the bell turn on or off. If your base station display shows the toggled condition for each of the function keys, you can determine which feature will turn on or off when a Function Group One or a Function Group Two is sent.
My locomotive makes no sounds except an air release when power is applied and will not operate.	You have your locomotive in Shut Down. Double press the F6 Start-Up key to start your locomotive.
My locomotive runs but makes no sounds.	Your have Mute on or have turned down your System Volume or individual feature sound volumes. You may have a broken wire to the speakers or a faulty speaker.
When I turn up my throttle to higher values, the locomotive does not speed up but instead, the directional lighting comes on.	Your locomotive is set for 14 speed steps but your base station is set for 28 or 128.
When I turn on my lighting system with the F0 or FL Key, the locomotive speeds up at low throttle settings.	Your locomotive is set for 28 or 128 speed steps but your base station is set for 14.
Sometimes my locomotive slows down when I blow the whistle or horn, particularly at high volume levels.	The Quantum Sound system takes additional power to blow the whistle or horn and this loads your power pack. This can lower the voltage on the track and your locomotive will slow down. Purchase a power pack with good line regulation to prevent this problem.
In Speed Control Mode, there are no speed changes above certain throttle settings.	The top speed of your locomotive is dependent on the gear ratio, load on the locomotive and the available voltage applied to the track. Asking the locomotive to go faster results in no change. (See CV 56.10 for Scale Factor to change throttle range).
Under speed control, I do not get 1 scale mile per hour (smph); I get a larger number about 5 to 10 smph.	Check your speed step setting on your base station. To get 1 smph you need to be in 128 speed steps.
In Throttle Control Mode, there are no speed changes above a certain throttle settings.	Try a different speed curve or define your own to provide full range of throttle motion.
My locomotive operates with no problem in DCC, but does not operate at all under Analog control.	Make sure Analog operation is enabled. CV29 bit 2 must be set to 1.
My Lionel Gas Turbine will not operate over 25 smph under RTC or Speed Control.	This is correct for diesel operation. This is an internal limit on top speed when the locomotive is under diesel operation. The prototype would not travel over 25 mph under diesel power. Switch to turbine operation to gain higher speeds.
F8 key on Digitrax does not mute the locomotive.	The Digitrax DT400 model we examined behaves incorrectly when the F8 key is pressed sending 1010DDDD instead of 1011DDDD. Ask Digitrax for a Software Upgrade.

Service Mode Operation using the Program Track

<p>My Quantum equipped locomotive will not program in Service Mode with my command station.</p>	<p>Some command stations do not provide sufficient current to power the Quantum system. If you are using a command station that has selectable track voltage for the different scales try using the O' Scale or G'Gauge alternative. If this does not work, use Ops Mode programming. You can also purchase from Tony's Train Exchange®¹²², a simple, inexpensive power booster (PowerPak™ by DCC Specialties) that will allow you to program on the program track with any DCC command station.</p>
<p>Occasionally, when programming CV, the reported value is off by one digit.</p>	<p>This is timing issue with some command stations. Either program in Ops Mode or consider using a PowerPak from DCC Specialties.</p>
<p>When I try to do a complete reset of all CV's using CV 56.128.255 in Program Mode, not all of the CV's reset to factory values.</p>	<p>Resetting all CV's takes considerable time. Some command stations only allow a fixed short amount of time to power the programming track after a command is sent. When you ask for a complete reset, not all of the CV's will be reset if the power shuts down part way through the procedure. We recommend doing a full reset in Ops mode. Or you can do individual reset operations such as "all NMRA CV reset", and "all QSI CV reset", etc. until you have all groups of CV's reset to factory defaults.</p>

¹²² Tony's Train Exchange; 1-800-978-3427; info@tx-dcc.com .

Appendix IVa

Using the Quantum Hardware Reset and Volume Controls:

Quantum software can be programmed by the operator to reset the system to factory defaults. As a safety precaution, Quantum also has a backup hardware method to do a system reset. Either method can be used to reset the locomotive to original factory settings. In case your Quantum Sound and Train Control System misbehaves and simply turning the power off from 5 to 15 seconds does not return it to normal operation, you can reset your locomotive using CV 56.128 or you can use the hardware Reset Jumper found on earlier Quantum Systems or the Magnetic Wand to activate a reed switch included on more modern Quantum Systems.

Quantum system volume can also be adjusted using software by programming CV 51.0 or by a hardware volume adjustment. Earlier Quantum systems used a potentiometer volume control and later models use a magnetic wand.

Reset Jumper Models

Both early Quantum Steam and Diesel locomotives used jumpers and volume potentiometers to control reset and sound volume. The diagram below shows a Quantum circuit board used in some Steam locomotive tenders. The jumper and volume potentiometer is located on the bottom board as shown in the diagram below.

To Reset the Locomotive:

- Turn off the main track power.
- For Steam locomotives, remove the tender body or water filler hatch to reveal the circuit board. If it is a plastic tender, there are no screws; it is a press fit to the chassis. Die cast tenders will have retaining screws under the chassis. Most Diesels will have a removable access panel over the Quantum circuit board on the roof. The location of the access panel will be shown in the Steam or Diesel Model Specification sheet that was included with your locomotive instructions.
- To reset the Quantum system to its default values, locate the black “clearing” jumper (see below) and remove by pulling it up.
- Reapply main track power, the horn and/or bell will sound after a few seconds.
- Turn main track power off and reinstall jumper, and tender cab or access panel. The locomotive has now been returned to original factory settings including all Analog and DCC settings.

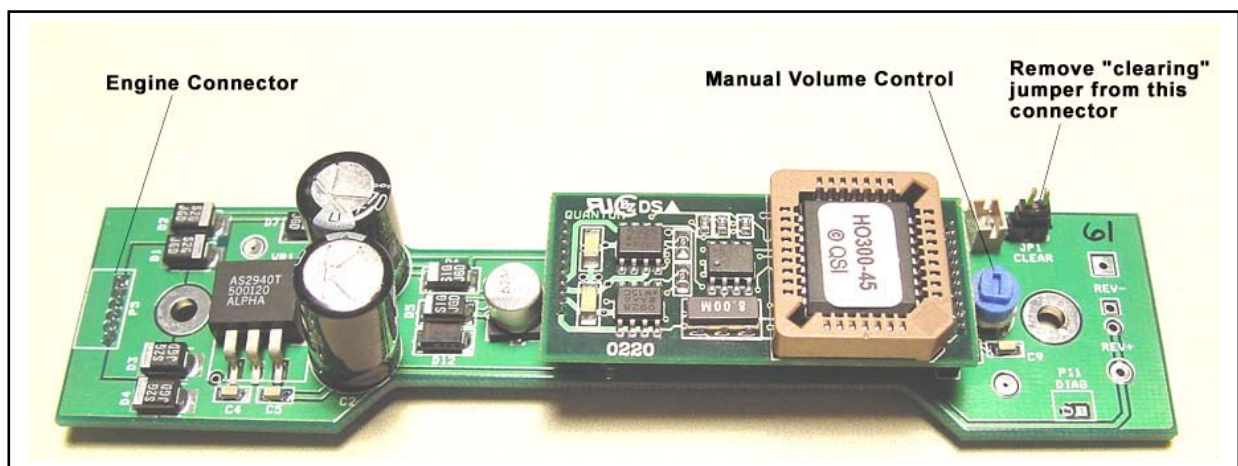

Note: Do not try to perform the jumper reset operation on the Program Track under Service Mode power. Always perform this operation under full power.

To Adjust the Volume Using the Potentiometer:

- Locate the Manual Volume Control under the access panel on the roof of your Diesel or Electric locomotive or under the water hatch on Steam locomotive tender as shown in the Model Specification sheet that was included with your instructions.
- Turn on main track power. You may want to turn on and leave on some of the significant sound effects such as whistle/horn and bell.
- Use a small screwdriver to turn the volume clockwise to increase volume or turn it counterclockwise to decrease the volume.
- Replace the access panel or water hatch cover.

Note: Volume can also be adjusted digitally using the programming methods described in the programming sections of this manual.

Magnetic Wand Models

Modern Quantum Steam and Diesel models use a glass enclosed reed relay to reset the Quantum System or adjust the volume. The reed relay will close its contacts when the magnet supplied with your locomotive is placed in close proximity. The advantage of this method of adjusting your locomotive's volume or resetting it to factory defaults is that you do not need an access panel to gain access to the controls. Also the wand does not need to touch the body; it can be held a reasonable distance from the roof area to prevent possibly marring the painted surface.

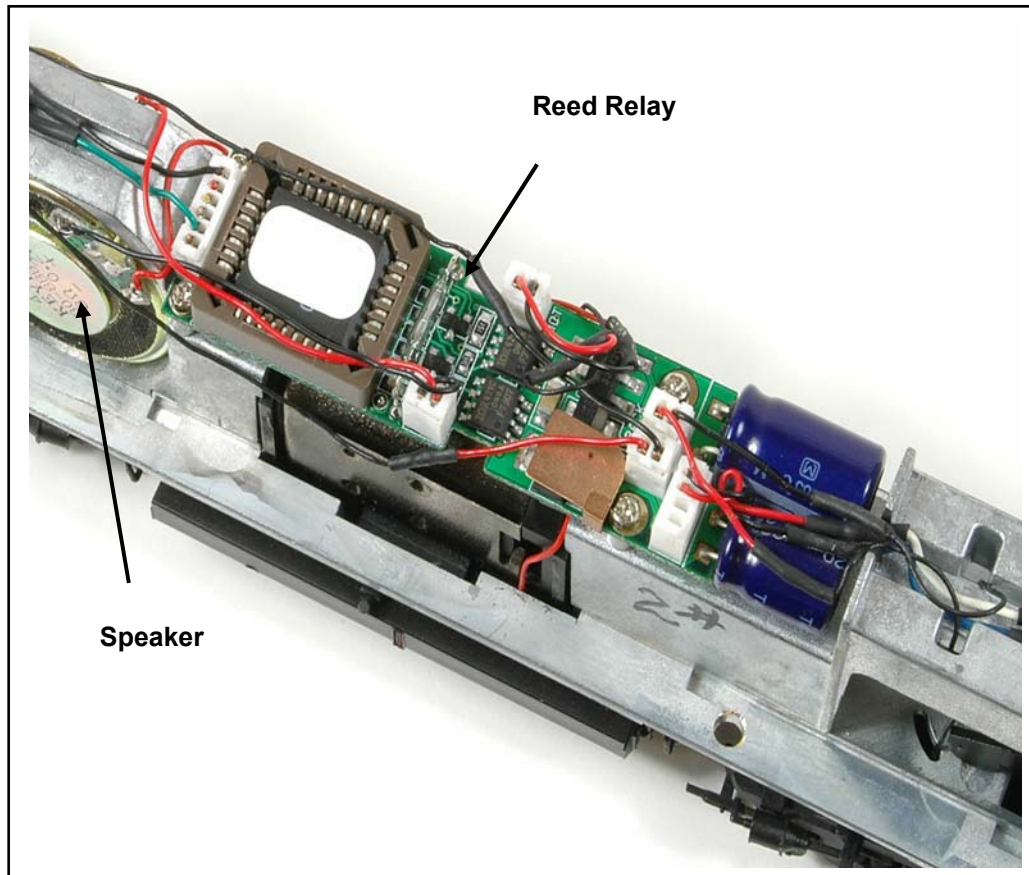

Quantum small diesel board with a reed relay mounted in a narrow-body diesel

To Reset the Locomotive:

- Locate the reed relay area as shown in the *Diesel or Steam Model Specifications* sheet that was included with your model.
- Turn off the track power.
- Place the Magnetic Wand over the reed switch area and re-apply track power and leave the wand there until you hear the word "reset". Remove the magnetic wand; your locomotive is now reset.

The locomotive has now been returned to original factory defaults including all DCC and Analog values.

Note: Do not try to perform this reset operation on the Program Track under Service Mode power. Always perform this operation under full power.

To Adjust the Volume Using the Magnetic Wand:

- Locate the reed relay area on the locomotive's roof as shown in the *Diesel or Steam Model Specifications* sheet that was included with your model.
- Power up locomotive and leave in Neutral.
- Place the enclosed Magnetic Wand over this reed switch area on the roof of the locomotive perpendicular to the track and wait as you hear the volume increase or decrease in incremental amounts as the Horn hoots about every second. Move the wand away and again place it over the reed area to change the direction (louder or softer) of the volume change. Remove the wand when you reach the desired volume level.

Appendix V

Different types of Feature Operation from Function Commands

QSI will often use the same function to control different effects depending on whether the system is in Neutral or a Motive state (Forward or Reverse). This allows us to increase the number of features available to DCC functions over the NMRA specified maximum of 14 (FL(f), FL(r), F1-F12). In addition, many QSI features respond to the Function inputs in different ways. It is the purpose of this section to describe how different Quantum features respond to function commands and help you get the most out of operating your locomotives. Also, if you intend to make your own output assignments for features using CV 53, it is important to know the implications of different types of features assigned to Neutral and to Forward/Reverse States for the same output.

Classification of DCC Signal Types

There is only one kind of function signal for DCC; either a function is “on” and transmits “1’s” every time the command is sent or “off” and transmits “0’s” every time the command is sent. However, Quantum has three different ways to respond to DCC function signals as illustrated below.

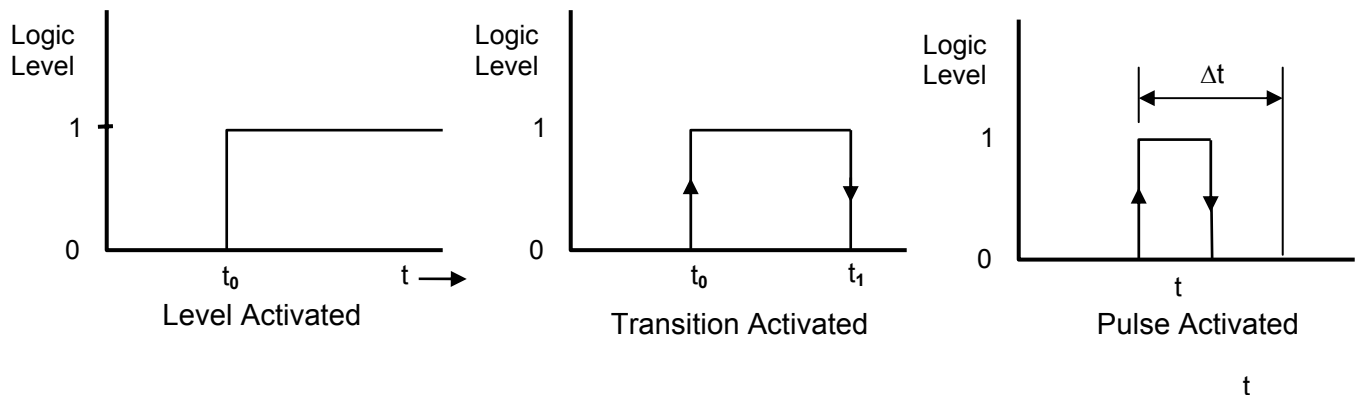

Level Activated: This is the classic response to a DCC function signal. If the DCC function signal is sent at level 0, the feature is not activated. If the DCC function signal is sent at level 1, the feature will activate. The above figure on the left shows a function signal being sent out at t_0 , where the level changes from “0” to “1” occur which will cause a Level Activated feature to respond. One possible advantage of Level Activated Signals is that the operator may know the status of a feature¹²³ by knowing the logic level that has been sent. However, since function signals are not continuously transmitted, the status of a feature prior to t_0 may not be known unless there had been a recent change to that function or to another function within the same function group.

Another advantage of Level Activated Features is that all locomotives in a Consist receive the same known command. For instance, if the horn feature is turned on, all locomotives blow their horns or if the Mute Feature is activated, all locomotives will mute their sounds or if directional lighting is turned off, all locomotives shut down their lighting.

Transition Activated: In this case, the feature is activated whenever there is a transition from level 0 to level 1 or from level 1 to level 0. In the above middle figure example, there would be a feature activation at t_0 and a second activation at t_1 . Since the feature is not responding to the logic level of the function signal, the value of the logic level cannot provide any information about the status of the feature.

Pulse Activated: Two transitions within a time period, Δt , is required for a Pulse Activated Feature to respond. It makes no difference if the pulse starts at level 0 or at level 1. The figure above shows a transition from level 0 to level 1 followed by a return to level 0, all within the allotted time period, Δt . The advantage of a pulse-activated feature is that it cannot be accidentally activated.

¹²³ This also depends on the type of feature. If it is a toggled or triggered feature such as an Air Let-Off, then the logic level provides no information.

Classification of Feature Types

Toggled Features: Features that switch between two states in response to a function command are toggled features. For instance, the Bell sound is a toggled feature; once it is turned on, it stays on, until it is commanded to turn off.

Toggled Features can be activated by any of the above function signals although we generally use Level Activation to operate toggled features. In this case, a Level 1 signal will cause the feature to be in one of the two known states, while a level 0 signal will cause it to be in the other known state. This allows the operator to know which state the feature is in by knowing the status of the function signal at his command station or his handheld. For instance, if the feature is a light which can be changed between on (level 1) and off (level 0), then the operator will know the light has been turned on when he sends a level 1 function signal, even if he cannot see the locomotive.

The Horn is also a toggled feature, which we assign to F2 as its factory default function key. When the F2 key is activated, then "1's" are sent and the horn sound comes on. The Horn will continue to blow until the F2 key is pressed again to produce "0's" whereupon the horn sound feature will turn off and stay off.

Some command stations have a horn button that can be pressed to operate the horn effect. The Horn sounds when the horn button is pressed and then turns off when the horn button is released. However, the horn button is a custom feature on those DCC controllers and does not act like a normal F2 function key. The horn button is designed to generate "1's" whenever the horn button is pressed and held down and send 0's when the horn button is released. Hence, while the Horn seems like a Momentary Feature when using the horn button, it is actually a Toggled Feature.

Other Toggled Features on Quantum include, Bell, Mute and Blower/Fans. While State Features can be affected by the directional state or other states in the locomotive, the features are nevertheless either "on" (enabled) or "off" (disabled) until changed.

Level Activation signaling is now assigned to most Toggled Features in Quantum. Air Brakes and Cruise Control on the Lionel® Challenger and the Gas Turbine are the only remaining toggled features that respond to Transition Activation.

State Dependent Toggled Features: Features may also change their state depending on other inputs besides function signals. The status of some features may change when power is turned off and reapplied, or the locomotive changes its motive state or the speed is changed. For instance, the Bell sound will turn off if power is cycled from on to off to on; Dynamic Brakes will shut off when the speed is reduced below 7smph or whenever the directional state of the locomotive is changed.

Momentary Features: These are single event features that return to their original status after they are activated. Examples are Air Let-offs, Brake Squeal in Forward and Reverse, Doppler shift and Neutral Events like Pop-off, Blow Down, etc. All Quantum Momentary Features are Transition Activated. Although it is possible to use Level Activation, it would seem to have limited use. For instance, you could have an Air Let-off respond only when the function signal goes to level 0 from level 1 but not respond when going from level 1 to level 0. This would provide an Air Let-off, every other time the function key was pressed.

Progressive Features: A Progressive Feature does two things when operated: 1) it activates the currently enabled feature and 2) it enables the next feature. The next time it is operated, it activates the newly enabled feature and enables the next feature. After no more features can be enabled, additional function signals have no affect. An example of a Progressive Feature is locomotive Shut Down. There are three stages to the shut down operation. Double pressing the F9 Key on a locomotive in Neutral will put it in Disconnect; the next double press operation of the F9 Key will put it in Standby; the next double press operation of the F9 Key will cause it to enter Total Shut Down. At this point, operating F9 key will have no further effect.

Both the Shut Down and Start Up features are Pulse Activated. This requires that the function key be double-pressed within one second to activate this feature. Double pressing ensures that this feature is not entered accidentally.

Enabled Features: Enabled or armed features are set to react to a second signal or condition to active the feature. An example is coupler arming which later generates a coupler opening sound effect when the Function Key is pressed again at a later time. Armed Features are unique in that they can supplant a specified features

reaction to a function signal until the feature is triggered. The Coupler Fire feature is an example of this since this feature will not occur until the coupler sound feature is armed.

Take Control Features: These are automatic features that can also respond to function key signals. Once the function signal is received, the automatic operation is disabled and the “Take Control” operation is enabled. That feature is then under complete control of the Function Key output signal. For instance, Automatic Blowers/Fans can be toggled to their on or off state by a function key signal and thereafter they lose their automatic operation and now only respond to their function key signal.

With “Take Control” features, there needs to be a way to clear the “Take Control” mode to return the feature to automatic operation. Quantum returns the Take Control feature back to automatic operation when power is turned off and reapplied or if the F6 Start Up Key is operated at any time.

Quantum Features and Control Types

The following table shows each feature that can be assigned to an output and the type of signal used to operate the feature. These include Level, Transition, or Pulse

LA = Level Activated

TA = Transition Activated

PA = Pulse Activated

SD-Toggled = State Dependent Toggled

Feature ID	Feature	Signal Type	Allowed States	Feature ID	Feature	Signal Type	Allowed States
0	Null Output		All	102	Directional Mars Light	LA Toggled	All
1	Whistle	LA Toggled	All	103	Mars Light	LA Toggled	All
3	Bell	LA Toggled	All	104	Strobe Mars Light	LA Toggled	All
5	Dynamic Brakes	LA SD-Toggled	All	105	Number Board Lights	LA Toggled	All
8	Blower Hiss/Diesel Cooling Fans	LA Toggled	All	107	Directional Headlight + Directional Mars Light	LA Toggled	All
9	Long Air Let-off	TA Momentary	All	108	Directional Headlight + Directional Ditch Lights	LA Toggled	All
10	Short Air Let-off	TA Momentary	All	109	Directional Ditch Lights	LA Toggled	All
12	Pop-off	TA Momentary	NFF/NFR	110	Ditch Lights	LA Toggled	All
13	Blow Down	TA Momentary	NFF/NFR	111	Strobe Ditch Lights	LA Toggled	All
14	Injector	TA Momentary	NFF/NFR	144	Start Up	PA Momentary	NFF/NFR
64	Mute	LA-SD Toggled	All	145	Shut Down	PA Progressive	NFF/NFR
65	Doppler Shift	TA Momentary	FWD/REV	176	Air Brakes	TA-SD Toggled	FWD/REV
96	Directional Headlight	LA Toggled	All	178	Status Report	TA Momentary	FWD/REV NFF/NFR
97	Directional Reverse Light	LA Toggled	All	177	Cruise Control	TA-SD Toggled	FWD/REV
98	Headlight	LA Toggled	All	211	Coupler Effect	TA Enable and TA Momentary	All
99	Dim Headlight	LA Toggled	All	215	Squealing Brakes	TA Momentary	FWD/REV
100	Reverse Light	LA Toggled	All	216	Squealing Brakes + Air Brakes	TA Momentary LA Toggled	FWD/REV
101	Automatic Cab Lights	LA Toggled	All	217	Pumps	LA Toggled	NFF/NFR

Quantum Default Features and Control Types

The following table shows our default feature assignments with function activation control and feature types indicated in blue in parenthesis.

LA = Level Activated

TA = Transition Activated

PA = Pulse Activated

SD-Toggled = State Dependent Toggled

Default F-Key	FWD/REV	NFF/NFR
FL(f)	Headlight Directional Lighting (LA Toggled)	Headlight Directional Lighting (LA Toggled)
FL(r)	Reverse Light Directional Lighting (LA Toggled)	Reverse Light Directional Lighting (LA Toggled)
F1	Bell (LA Toggled)	Bell (LA Toggled)
F2	Whistle/Horn (LA Toggled)	Whistle/Horn (LA Toggled)
F3	Coupler Crash-Coupler Fire (TA Momentary)	Coupler Arm (Enable) or Coupler Fire (TA Enabled or TA Momentary)
F4	Steam Blower Hiss/ (LA Toggled) Diesel Fans and Louvers/ Electric Cooling Fans	Steam Blower Hiss (LA Toggled) Diesel Fans and Louvers/ Electric Cooling Fans
F5	Dynamic Brakes (LA SD-Toggled)	Dynamic Brakes (LA SD-Toggled)
F6	Doppler Shift (TA Momentary)	Locomotive Start Up (PA Momentary)
F7	Brake Squeal-Flanges (TA Momentary) Air Brakes (TA-SD Toggled)	Long Air Let-off (TA Momentary)
F8	Sound Mute (LA Toggled)	Sound Mute (LA Toggled)
F9	Cruise Control (TA Toggled)	Shut Down ¹²⁴ : Disconnect-Low Idle set-Total Shut Down (PA Progressive)
F10	Status Report (TA Momentary)	Status Report (TA Momentary)
F11	Number Board Lights (LA Toggled)	Number Board Lights (LA Toggled)
F12	Automatic Cab Light (LA-SD Toggled)	Automatic Cab Light (LA-SD Toggled)

The features were designed and assigned to provide the greatest consistency of operation of the different types of locomotives (Steam, Diesel and Electric) as well as maintaining the greatest level of correspondence between the displayed function settings and operating feature status.

Note that FL(f), FL(r), F1, F2, F4, F8, F11 and F12 all are Level Activated Toggled Features. This means that the display for these features is likely to indicate the true status of the features.

Most other features are Transition or Pulse Activated Momentary type, which only respond to changes in the function inputs. Statuses for these features are not required since they return to their initial state after a short period. This includes F3, F6, F7, F9-Shut Down, and F10.

F8, Sound Mute, always comes on it its non-mute state when power is first applied. Since the F-Key status could be displayed as "1" during start up, it may not match the status of the Mute feature in the locomotive. However, the status of this feature is quite evident by the fact the locomotive is making sound. If the Mute Key is operated even once, the status of the Mute key function display will then match the locomotive Mute status for the remainder of the operating session.

Since Dynamic Brakes is a State Dependent feature, its status in the locomotive may not match the F-Key function display of "1". However, since the Dynamic Brakes will shut off whenever entering Neutral or slowing below 7smph, unless you hear the Dynamic Brakes or have recently turned them on with a level 1 setting, it is a fair assumption that they are off. If the display for F5 is "0", then the Dynamic Brakes are known to be off.

¹²⁴ There are three stages to Shut Down. To operate Shut down, you will need to double click the F9 key for each stage.

F9-Cruise Control is the only feature that will need to be monitored by observing or listening to the locomotive to determine if the feature is on or off. Since it is a Transition Activated Toggled Feature, the display status of F9 bears no relation to the actual Cruise Control status of the locomotive.

Appendix VI

Interaction of Function Keys, Function Groups, Function Inputs and Outputs and Feature Assignments

The diagram below shows graphically how the Function Keys, Function Groups, Function Inputs, and Outputs are configured and how they interact.

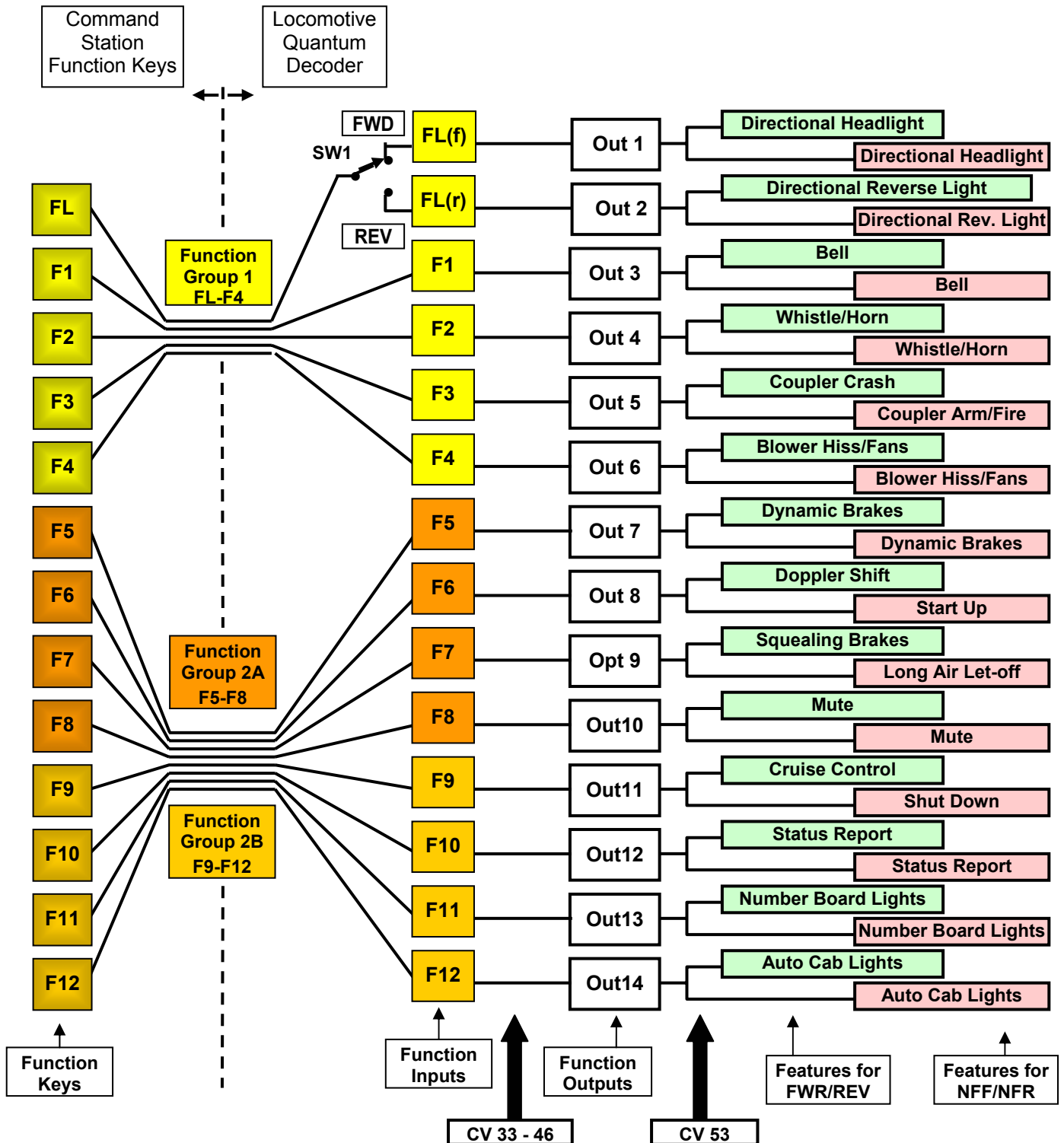

Function Keys and Function Groups: The thirteen colored squares shown on the left side of the dotted vertical line, designated FL, and F1 through F12 represent push buttons or Function Keys located at the Command Station or on the DCC walk-around throttle.

The Function Keys are shown color-coded depending on which Function Group they use to transmit their bit settings to the locomotive's decoder. Keys FL through F4 (Yellow) use Function Group 1 to send information to the locomotive. Keys F5 through F8 (Orange) and Keys F8 through F12 (Gold) both use Function Group 2 but not at the same time. Bit 5 in Function Group 2 specifies whether this Function Group applies to F5 – F8 or F8 - F12. Each Function Group command contains 4 or 5 bit settings for the Function Inputs.

The locomotive's decoder, shown to the right of the vertical dotted line, receives Function Group commands. Whenever a Function Group Command is sent, the function values are stored in memory as a Function Input, each with a logic level of 1 or 0.

Function Inputs and Outputs: Each Function Input is shown connected to a corresponding Function Output designed by the squares Out 1 through Out 14.

The boxed labeled "CV's 33-46" with black arrow pointing up indicates that these CV's determine which Function Input controls which desired Function Output. Function Inputs cannot be connected to any Function Output. For instance, Function Inputs FL through F3 can only be connected to Outputs 1 through 8 (see CV 33-37). The diagram shows the default connections between Function Inputs and Outputs. In the description of each CV 33-42, the default Output is shown with gray background [as an example, see CV 41 on page 72, which shows the Output locations for F7. The default is Output 7 (bit 5) and is shown with gray fill, which corresponds to Output 9].

The FL Function Key is special since it connects to two different Function Inputs depending on the locomotive's direction setting. This is shown schematically in the diagram where the position of the single-pole double-throw switch, SW1, is determined by the locomotive's direction (FWD or REV). In Forward (or Neutral from Forward), the switch, SW1 is in the top position which connects the FL Key to the FL(f) input. When the locomotive is in Reverse (or Neutral from Reverse), the SW1 would be in the bottom position, which connects the FL(f) Key to the FL(r) Input.

The default Outputs for FL(f) and FL(r) are Out 1 and 2 respectively. If the locomotive is in Forward or Neutral from Forward, the FL key will affect the features connected to Out 1. If the locomotive is in Reverse or Neutral from Reverse, the FL key will affect the features connected to Opt 2. Function Outputs 1 and 2 are generally used for directional lighting effects and are usually assigned to the FL(f) and FL(r) Inputs respectively, which are the Quantum default settings.

Although each Function Input is shown connected to only one Output, there is no restriction in connecting an Input to more than one Output. This can be useful if it is desired to control two or more features at the same time. For instance, it might be desired to have the Bell turn on at the same time the Reverse Light is turned on by the FL(r) Key or to have Ditch Lights operate at the same time the Horn is activated.

Since there are only fourteen Inputs and fourteen Outputs, if more than one Output is connected to an Input, there may be unused Inputs.

Of course, the unused Inputs could be connected to other Outputs that are already assigned but this is not recommended. Because there is more than one Input controlling an Output, it is unclear which Input has control. The software is written such that the common Output would be on if any of its Inputs are on. In other words, the Output is off if and only if all connected Inputs are off¹²⁵.

Outputs that are not connected to a Function Input are always off.

Outputs and Features: The box labeled "CV 53" with black arrow pointing up indicates that this CV determines which feature is connected to which Output. CV 53 also allows different features or accessories to be assigned to the Neutral States (locomotive stopped) or to a Motive States (Forward/Reverse). Features shown in the green boxes are assigned to the Motive States and features shown in the red boxes are assigned to the Neutral States. The diagram shows the default Quantum features assigned to the different Function Outputs for Motive and Neutral states.

¹²⁵ In other words, the Inputs to a common Output are OR'ed.

Effects of Mixing Different Types of Features: Quantum previously had restrictions on assigning to the same output different types of features with different feature activation methods (Level, Transition or Pulse) for operation in Neutral or Forward/Reverse. The reasons were obvious. If you assigned one feature for operation in Neutral and then another for Forward/Reverse, then the function Input would be changed for both. For instance, if the Bell was assigned to Output 3 in Forward/Reverse and Number Board Lights assigned to Output 3 in Neutral, than there is an issue of what would happen to the Number Board Lights if you turned on the Bell in Forward by sending out a level 1 function and then entered Neutral? The function Input for Output 3 is still at the new value of level 1. Do the Number Board Lights automatically come on, if previously off?

To avoid this problem, we have a simple rule:

An Output for a particular directional state (Forward/Reverse or Neutral) will change state, if and only if its Function Input changes while in that directional state.

There would seem to be another way that we could accidentally operate a feature. We could make the change to a feature assigned to an output in one directional state, and after we change to a new directional state, we operate some other function within the same function group. For instance, in the above example, we could turn on the Bell in Forward/Reverse with a level 1 Function Input signal, followed by operating the Horn in Neutral. Now when the common function group, Function Group 1, command packet is sent, it will also change the function input for Output 3 and would turn on the Number Board Lights. However, the above rule still applies since the function input did not change; it remained at level 1, and hence its output did not change. In order for the operator to turn on the Number Board Lights in this case, he would need to send a level 0 function followed by a level 1 function to Output 3 while in Neutral.

The main difficulty with mixing different features in Neutral and Forward/Reverse, is that the status of the function at the command station or handheld, does not match the expected associated behavior of assigned toggled features. This is compounded by state dependent toggled features where other inputs can change the status of a feature independent of the function commands and also by Transition or Pulse Activated toggled features, where the function input level has no bearing on the feature status. While an operator may not know what the status of some features are, he does know that whenever a function input is changed, the function input in the Quantum decoder will match the value indicated at the command station or the handheld during the entire uninterrupted operating session¹²⁶. The operator can also infer that for most Level Activated Toggled Features, the state of a feature will match the associated level of the function signal directly after sending a function signal. In other words, the operator will know that he has turned on the Number Board Lights directly after he has sent out the appropriate level 1 function for that feature.

Note that these issues only apply to toggled features. There certainly is no issue for Momentary Features, where they always return to their original status, or any other features that are Transition or Pulse activated.

¹²⁶ Unless he selects a different locomotive whereupon all indicated function key status may very well have no relationship with the function inputs in the newly selected locomotive's decoder.

Appendix VII

Recommended Reading:

Ames, S., Friberg, R., and Loizeaux, E. *Digital Command Control*. Allt om Hobby 1998.

Ireland, Zana (Editor In Chief), *The Digitrax Big Book of DCC*, Digitrax, 1999.

Strang, Lionel, *DCC Made Easy*, Kalmbach Publishing 2003.

Polsgrove, Mike, *DCC Projects & Applications*, Kalmbach Publishing, 2006.

Appendix VIII

Application Notes:

Using DC Power Conversion for Block Signal Control

CV 29, Bit 2 =1. Applications for DC Power Conversion: Block Signal Control

DCC Power Conversion as described under CV 29, bit 2, was implemented into Quantum in a way that allows for simple block signal control. Using DC power conversion allows the operator to enable a red signal light to stop a train smoothly, using its internal momentum settings, without having to use the throttle. If Bit 2=1 for CV 29, a DCC controlled locomotive will automatically engage DC Power Conversion when it enters a section of track that is powered with standard DC. If the polarity would normally power the analog locomotive in the direction it is going when it enters the DC section, the locomotive will continue through the DC block at the same speed. If the polarity would normally power the locomotive in the Reverse direction, the locomotive will smoothly come to a stop in the DC section.

The diagram below shows a DCC section connected to a DC section of track. The DC section is powered from the DCC power signal rather than from a separate power supply or battery. For this application, it is only necessary to insulate the one rail as shown by the two insulated rail joiners at either end of the DC section; the other rail is electrically connected to the DCC section by conductive rail joiners.

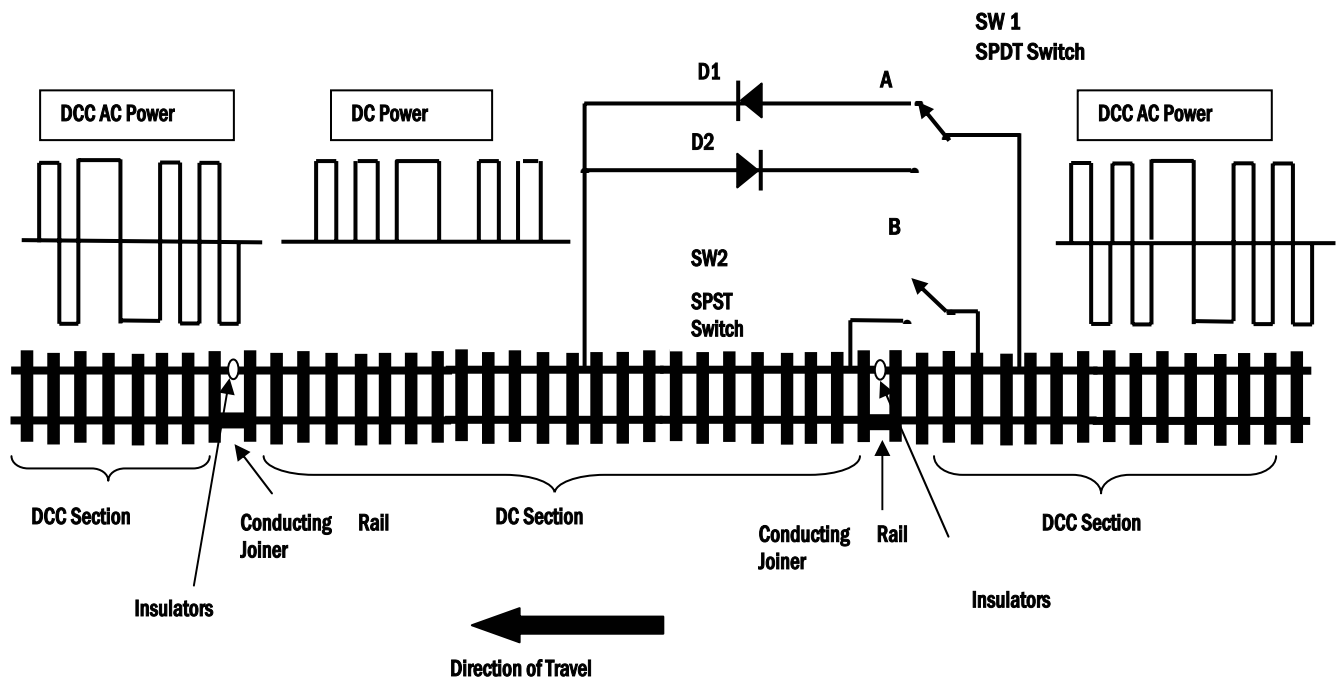

When switch 2 (SW 2) is open, the DCC signal is half-wave rectified by diodes D1 or D2 to produce a positive DC signal to the DC section when Switch 1 is at position A or a negative DC signal when Switch 1 is at position B. If Switch 2 is closed, the DCC signal is connected directly to the DC section and D1 and D2 have no effect on applying DC power to the DC section.

If DC power conversion is enabled in CV 29 (bit 2 = 1) and SW 2 is open, the polarity on the DC section can be used to stop the Quantum equipped train or let it precede, depending on the position of SW 1. If the locomotive is entering the DC section from the right, and SW 1 is set to A, the locomotive will continue at its current speed setting through the DC section. The locomotive, of course, will not respond to DCC signals until it leaves the DC section and reenters the DCC powered section at the far left. On the other hand, if SW 1 is set to B, the polarity on the DC section is opposite the locomotive's direction and the locomotive will slow to a stop at its DCC momentum setting. If the polarity is reversed again to be consistent with the locomotive's direction, the locomotive will accelerate at its current DCC momentum setting to leave the DC section. Alternately, SW 2 could have been closed to cause DCC signals to be applied to the stopped locomotive, which would also have caused the locomotive to accelerate at its current DCC momentum value to its DCC speed setting.

Since the DC portion is powered from the DCC signal, there are no short circuit problems between the DCC powered section and the DC section as the locomotive wheels pass over the track insulators. In addition, since the Quantum locomotive is equipped with large filter capacitors, the reduced power of half-wave rectification will not affect the power available to operate the locomotive so there is minimal slow down effect. Also, if the train is made up of a series of Quantum locomotives in a Consist, and the polarity is set to stop the train, each locomotive in turn will couple the DCC signal through to the DC section until the last locomotive has passed over the boundary; only then will the entire Consist come to a stop.

The above diagram is simplified to make it easy to describe the basic concept. Switch 1 can be a relay powered by a train detector on the next block to do automatic train control. In addition, Switch 1 could have extra contacts to control red and green signals for the actual block signal. Switch 2 could also be part of a relay network for all DC blocks to disable or enable block signal operation.

D1 and D2 should be rated at 2 amps minimum and have a breakdown voltage of 30 volts or more.

Appendix IX

Binary, Hexadecimal, Decimal Conversions

Decimal	Hex	Binary	Decimal	Hex	Binary	Decimal	Hex	Binary	Decimal	Hex	Binary
0	00	00000000	64	40	01000000	128	80	10000000	192	C0	11000000
1	01	00000001	65	41	01000001	129	81	10000001	193	C1	11000001
2	02	00000010	66	42	01000010	130	82	10000010	194	C2	11000010
3	03	00000011	67	43	01000011	131	83	10000011	195	C3	11000011
4	04	00000100	68	44	01000100	132	84	10000100	196	C4	11000100
5	05	00000101	69	45	01000101	133	85	10000101	197	C5	11000101
6	06	00000110	70	46	01000110	134	86	10000110	198	C6	11000110
7	07	00000111	71	47	01000111	135	87	10000111	199	C7	11000111
8	08	00001000	72	48	01001000	136	88	10001000	200	C8	11001000
9	09	00001001	73	49	01001001	137	89	10001001	201	C9	11001001
10	0A	00001010	74	4A	01001010	138	8A	10001010	202	CA	11001010
11	0B	00001011	75	4B	01001011	139	8B	10001011	203	CB	11001011
12	0C	00001100	76	4C	01001100	140	8C	10001100	204	CC	11001100
13	0D	00001101	77	4D	01001101	141	8D	10001101	205	CD	11001101
14	0E	00001110	78	4E	01001110	142	8E	10001110	206	CE	11001110
15	0F	00001111	79	4F	01001111	143	8F	10001111	207	CF	11001111
16	10	00010000	80	50	01010000	144	90	10010000	208	D0	11010000
17	11	00010001	81	51	01010001	145	91	10010001	209	D1	11010001
18	12	00010010	82	52	01010010	146	92	10010010	210	D2	11010010
19	13	00010011	83	53	01010011	147	93	10010011	211	D3	11010011
20	14	00010100	84	54	01010100	148	94	10010100	212	D4	11010100
21	15	00010101	85	55	01010101	149	95	10010101	213	D5	11010101
22	16	00010110	86	56	01010110	150	96	10010110	214	D6	11010110
23	17	00010111	87	57	01010111	151	97	10010111	215	D7	11010111
24	18	00011000	88	58	01011000	152	98	10011000	216	D8	11011000
25	19	00011001	89	59	01011001	153	99	10011001	217	D9	11011001
26	1A	00011010	90	5A	01011010	154	9A	10011010	218	DA	11011010
27	1B	00011011	91	5B	01011011	155	9B	10011011	219	DB	11011011
28	1C	00011100	92	5C	01011100	156	9C	10011100	220	DC	11011100
29	1D	00011101	93	5D	01011101	157	9D	10011101	221	DD	11011101
30	1E	00011110	94	5E	01011110	158	9E	10011110	222	DE	11011110
31	1F	00011111	95	5F	01011111	159	9F	10011111	223	DF	11011111
32	20	00100000	96	60	01100000	160	A0	10100000	224	E0	11100000
33	21	00100001	97	61	01100001	161	A1	10100001	225	E1	11100001
34	22	00100010	98	62	01100010	162	A2	10100010	226	E2	11100010
35	23	00100011	99	63	01100011	163	A3	10100011	227	E3	11100011
36	24	00100100	100	64	01100100	164	A4	10100100	228	E4	11100100
37	25	00100101	101	65	01100101	165	A5	10100101	229	E5	11100101
38	26	00100110	102	66	01100110	166	A6	10100110	230	E6	11100110
39	27	00100111	103	67	01100111	167	A7	10100111	231	E7	11100111
40	28	00101000	104	68	01101000	168	A8	10101000	232	E8	11101000
41	29	00101001	105	69	01101001	169	A9	10101001	233	E9	11101001
42	2A	00101010	106	6A	01101010	170	AA	10101010	234	EA	11101010
43	2B	00101011	107	6B	01101011	171	AB	10101011	235	EB	11101011
44	2C	00101100	108	6C	01101100	172	AC	10101100	236	EC	11101100
45	2D	00101101	109	6D	01101101	173	AD	10101101	237	ED	11101101
46	2E	00101110	110	6E	01101110	174	AE	10101110	238	EE	11101110
47	2F	00101111	111	6F	01101111	175	AF	10101111	239	EF	11101111
48	30	00110000	112	70	01110000	176	B0	10110000	240	F0	11110000
49	31	00110001	113	71	01110001	177	B1	10110001	241	F1	11110001
50	32	00110010	114	72	01110010	178	B2	10110010	242	F2	11110010
51	33	00110011	115	73	01110011	179	B3	10110011	243	F3	11110011
52	34	00110100	116	74	01110100	180	B4	10110100	244	F4	11110100
53	35	00110101	117	75	01110101	181	B5	10110101	245	F5	11110101
54	36	00110110	118	76	01110110	182	B6	10110110	246	F6	11110110
55	37	00110111	119	77	01110111	183	B7	10110111	247	F7	11110111
56	38	00111000	120	78	01111000	184	B8	10111000	248	F8	11111000
57	39	00111001	121	79	01111001	185	B9	10111001	249	F9	11111001
58	3A	00111010	122	7A	01111010	186	BA	10111010	250	FA	11111010
59	3B	00111011	123	7B	01111011	187	BB	10111011	251	FB	11111011
60	3C	00111100	124	7C	01111100	188	BC	10111100	252	FC	11111100
61	3D	00111101	125	7D	01111101	189	BD	10111101	253	FD	11111101
62	3E	00111110	126	7E	01111110	190	BE	10111110	254	FE	11111110
63	3F	00111111	127	7F	01111111	191	BF	10111111	255	FF	11111111

Appendix X

Rights and Obligations

QSIndustries, Inc. Software License Agreement

1. Grant of License: QSIndustries, Inc. grants you, the owner, the right to use the software that is included with your Quantum system only with the Quantum equipped locomotive that you purchased.
2. Copyright: The software is owned by QSIndustries, Inc. and is protected by United States copyright laws and international treaty provisions. Therefore, neither you nor anyone else may copy the software.
3. Limited Warranty: QSI does not offer an explicit Software warranty. Check with individual manufacturers on details for Software warranty.

Proprietary Rights and Obligations

The structure and organization of the Software/Firmware are the valuable property of QSIndustries, Inc. You will not make or have made, or permit to be made, any copies of the Hardware, Software/Firmware, code, or any portions thereof. You are not to modify, adapt, translate, reverse engineer, de-compile, disassemble or create derivative works based on the Hardware or Software/Firmware. Trademarks shall be used in accordance with accepted trademark practice, including identification of trademark owner's name. The Quantum Hardware, Software and Firmware are covered by U.S. Patent No. 4,914,431; 5,184,048; 5,267,318; 5,394,068; 5,448,142; 5,633,985; 5,832,431; 5,896,017; 5,940,005; and other US and Foreign patents pending.

No Other Rights

QSIndustries, Inc. retains ownership of the Quantum Hardware design and operating Software/Firmware code. Except as stated above, this agreement does not grant you any rights to intellectual property rights to the Quantum Software, Firmware or Hardware. The use of any trademarks as herein authorized does not give you any rights of ownership in that trademark.

Index

A

About Quantum Decoder 108
Acceleration 9, 17, 22, 25, 31, 32, 42, 47, 50, 85
Acceleration Inertia 31
Acceleration Speed Steps 31
Acknowledgements 23, 24
Acknowledgements (Verbal) 24, 88, 89
Adjust Volume with Magnetic Wand 152
Air Brakes 116, 117, 119
Air Brakes (F7) 16
Air Brakes in Neutral (F7) 16
Air Horns 117, 121
Air Pumps 18, 95, 99, 115, 116, 117, 118, 119, 120, 121, 122, 156
Air Release 16, 115, 119, 121
Analog Control 7, 15, 30, 52, 91
Applied Motor Voltage 30, 33
Apply Air Brakes 16
Articulated Chuff 115
Automatic Features 19
Automatic Sounds, Diesel 116
Automatic Sounds, Electric 119
Automatic Sounds, Gas Turbine 121
Automatic Sounds, Steam 115

B

Bell7, 11, 13, 15, 25, 43, 55, 57, 59, 61, 63, 65, 66, 94, 95, 97, 100, 111, 115, 119, 143, 148, 150, 156, 160
Bell Button 14
Bells 117, 121
Block Signal Control 163
Blow Down 21, 45, 81, 83, 95, 97, 115, 154, 156
Blowers and Fans 11, 14, 18, 19, 20, 43, 44, 55, 56, 58, 60, 62, 64, 66, 67, 69, 71, 73, 75, 95, 96, 97, 100, 115, 116, 156, 157
Brake 117
Brake Squeal 11
Brake, Bell, Air Release Malfunction 148
Brakes 115, 119, 121
Brakes (Automatic) 16
Brakes Sounds (Extended) 16
Braking Value 16
Build Information 109
Byte (8 bit word) 53

C

Cab Lights 11, 18, 20, 45, 98, 116, 120, 156
Cab Lights Disabled 45
Chuff 17, 95
Chuff per Wheel Revolution 104
Classification of DCC Signal Types 153
Classification of Feature Types 154
Command Station 39, 53, 55
 Entering Extended Address in Ops Mode 107

 Entering Primary Address in Ops Mode 106
 Function Keys 55
 Programming CV's Directly 39
 Programming Options 53, 106
 Recommended 143
 Setting Train Number 40
 Troubleshooting Headlight 148
 Troubleshooting Programming 149
Command Station Note 15, 23, 29, 41, 91, 92, 102
Command Station Quantum Operation 41
Command Stations 7, 23, 39
Concave "Slow Start" Curves 50
Configuration Variables (CV's) 7, 8, 9, 22
Configuration Variables Explained 22
Conformance 23
Consist 10, 42, 43
Consist Address 22, 25, 42, 43, 45
Controllable Sounds, Diesel 117
Controllable Sounds, Electric 119
Controllable Sounds, Gas Turbine 121
Controllable Sounds, Steam 115
Convex "Fast Start" Curves 50
Cooling Fans 116, 119, 121
Coupler Air-Lines 14
Coupler Arm 14
Coupler Crash 14
Coupler Fire 14
Coupler Lift Bar 14
Coupler Sounds 11, 14, 43, 95, 99, 100, 116, 117, 119, 122, 156, 157
Coupler Sounds, Operation .. 57, 59, 61, 63, 65, 67, 69, 71, 73, 75
Coupling Pin 14
Cruise Control 10, 11, 17, 21, 45, 55, 68, 70, 72, 74, 76, 99, 100, 156, 157
Curve Tables in order of value for CV 25 50
CV 1 Primary Address Control 25, 29
CV 1: Primary Address Register 29
CV 1: Primary Address Register 28
CV 11 Packet Time-out Value 25, 38
CV 17, 18 Extended Address 25, 39, 53
CV 17: Extended Address Most Significant Byte Register 39
CV 18: Extended Address Least Significant Byte Register 39
CV 19 Consist Address 25, 42
CV 19: Consist Address Active for FL and F9-F12 Register 42
CV 2 V-Start 25, 30, 51
CV 2: V-Start Register 30
CV 21 Consist Address Active for F1-F8 25, 42, 43, 45
CV 21: Consist Address Active for F1-F8 Register 43
CV 22 Consist Address Active for FL 25, 42, 43, 45
CV 22: Consist Address Active for FL and F9-F12 Register 45
CV 23 Acceleration Adjustment ... 11, 25, 38, 42, 47, 53

CV 23: Acceleration Adjustment Register	47	CV 50: Secondary Index Register (SI)	89
CV 24 Deceleration Adjustment .. 11, 25, 38, 42, 48, 53		CV 51 QSI System Sound Control	17, 26, 91
CV 24: Deceleration Adjustment Register	48	CV 51.0 Operations Mode System Volume	91
CV 25 Quantum Speed Table Selection	25, 49	CV 51.0: Ops Mode System Volume Register	91
CV 25: Quantum Speed Table Selection Register ...	49	CV 51.1 Operations Mode Mute Volume	92
CV 29 Configuration Data	25, 52	CV 51.1: Ops Mode Mute Volume Register	92
Accessory Decoder	53	CV 51.2 Special Sound Effects Enable	93
Advanced Acknowledgement	53	CV 51.2: Special Sound Effects Enable Register	93
Common Settings	54	CV 52.PI QSI Individual Sound Volumes	26, 94
Direction Control	52	CV 52.PI: Individual Sound Volume Registers	94
Extended Address	53	CV 53 Output Feature Assignment ..26, 43, 45, 56, 57,	
FL Location	52	59, 61, 63, 65, 67, 69, 73, 75, 77, 79, 81, 83, 86, 87,	
Multifunction Decoder	53	96, 160	
Power Source Conversion	52	CV 53.PI.SI: Output Feature Assignment Register ..	96
Speed Table	53	CV 55 QSI Feature Configuration	101
CV 29, Bit 2 =1. Applications for DC Power		CV 55.110.5 Ditch Light Strobe Time	101
Conversion: Block Signal Control	163	CV 56 QSI Configuration	26, 102
CV 29: Configuration Data Register	52	CV 56.10: Speed Step to Scale MPH Scale Factor	
CV 3 Acceleration Rate	11, 25, 31, 38, 47, 53	Register	103
CV 3: Acceleration Rate Register	31	CV 56.10: Speed Step to Scale MPH Scale Factor	103,
CV 30 Error Information	25	104	
CV 33 Output Function Location for FL(f)	25, 57	CV 56.12: Chuff Interval Scale Factor Register	104
CV 33: Output Location for FL(f)	57	CV 56.128: Reset to Factory Default Register	105
CV 33-46 Output Location Overview	55	CV 56.128: Reset to Factory Default	105
CV 34 Output Function Location for FL(r)	25, 59	CV 56.129: Engine ID Access Register	106
CV 34: Output Location for FL(r)	59	CV 56.129: Engine ID Access	41, 106
CV 35 Output Function Location for F1	25, 61	CV 56.254: About Quantum Decoder	108
CV 35: Output for F1	61	CV 56.255: Play Build Information Register	108
CV 36 Output Function Location for F2	25, 63	CV 56.255: Play Build Information	108
CV 36: Output Location for F2	63	CV 56.4: QSI Throttle Mode Register	102
CV 37 Output Function Location for F3	26, 65	CV 56.4: QSI Engine Configuration	101, 102
CV 37: Output Location for F3	65	CV 6 V-Mid	25
CV 38 Output Function Location for F4	26, 67	CV 62 QSI Control	26, 110
CV 38: Output Location for F4 Register	67	CV 62: QSI Control Register Disable Verbal	
CV 39 Output Function Location for F5	26, 69	Acknowledgement	110
CV 39: Output Location for F5 Register	69	CV 64 Numeric Verbal Readout (Verbal CV Inquiry)	26,
CV 4 Deceleration Rate	11, 25, 32, 38, 48, 53	88, 111	
CV 4: Deceleration Register	32	CV 64: Numeric Verbal Readout Register	111
CV 40 Output Function Location for F6	26, 71	CV 65 Kick Start	26
CV 40: F6 Output Function Location	28	CV 66 Forward Trim	26, 112
CV 40: F6 Output Location for F6 Register	71	CV 66: Forward Trim Register	112
CV 41 Output Function Location for F7	26, 73	CV 67-94 User Defined Speed Table	113
CV 41: Output Location for F7 Register	73	CV 67-94: User Defined Speed Registers	113
CV 42 Output Function Location for F8	26, 75	CV 7 Manufacturer's Version Number	25, 36
CV 42: Output Location for F8 Register	75	CV 7: Manufacturer's Version Number Register	36
CV 43 Output Function Location for F9	26, 77	CV 8 Manufacturer's ID	25, 37
CV 43: Output Location for F9 Register	77	CV 8: Manufacturer's ID Register	37
CV 44 Output Function Location for F10	26, 79	CV 9 Total PWM Period	25
CV 44: Output Location for F10 Register	79	CV 95 Reverse Trim	114
CV 45 Output Function Location for F11	26, 81	CV 95: Reverse Trim Registers	114
CV 45: Output Location for F11 Register	81	CV's	
CV 46 Output Function Location for F12	26, 83	Manufacturer Unique	85
CV 46: Output Location for F12 Register	83	QSI Shorthand Notation	86, 87, 88
CV 49 QSI Primary Index	26, 88, 94	CV's	
CV 49: Primary Index Register (PI)	88	Descriptions and Overview	28
CV 49: Primary Index Register	28	CV10 EMF Cutout	25
CV 49-64, QSI Configuration Variables Overview	85		
CV 5 V-High	25, 33, 51		
CV 50 QSI Secondary Index	26, 89		

D

DCC Locomotive Operation (Getting Started).....	9
Deceleration.....	9, 17, 25, 32, 48, 50, 85
Deceleration Inertia.....	32
Deceleration Speed Steps.....	32
Deceleration, Actual.....	32
Decoder.....	22, 23, 42, 53, 56, 96
Decoder Outputs.....	55, 56
Diesel Automatic Sounds.....	116
Diesel Controllable Sounds.....	117
Diesel Engine Start Up.....	19
Diesel Locomotive.....	7, 14, 18
Diesel Motor.....	17, 95
Diesel Motor Rev.....	18, 116, 121
Diesel Sounds.....	116
Diesel Take Control Operation.....	20
Diesel Turbo.....	116
Dim Headlight.....	9, 12
Direction Control.....	9, 31, 32
Direction Key.....	9
Directional Ditch Lights.....	156
Directional Lighting ...	11, 12, 13, 18, 52, 57, 59, 61, 63, 65, 160
Directional Lighting System (see also F0).....	12
Disconnect....	17, 19, 68, 70, 72, 74, 76, 78, 80, 82, 84
Ditch Lights.....	160
Ditch Lights Strobe when Horn Blows.....	13
Doppler ..	15, 17, 21, 55, 56, 58, 60, 62, 64, 66, 68, 70, 72, 74, 76, 77, 79, 81, 83, 86, 93, 97, 100, 156
Doppler Bell Effect.....	15
Doppler Operation.....	15
Doppler Run-by.....	116, 117, 119, 122
Doppler Shift.....	11, 43
Doppler Shift (Horn Button Method).....	15, 93
Double Press.....	17, 18, 19, 21
Dynamic Brakes..	11, 14, 15, 18, 58, 60, 62, 64, 66, 67, 69, 71, 73, 75, 77, 79, 81, 83, 87, 95, 97, 100, 116, 117, 119, 122, 157
Dynamo (steam).....	12, 13, 95

E

Effects of Mixing Different Types of Features.....	161
Electric Loco Start Up.....	19
Electric Locomotive.....	7, 14, 18
Electric Locomotive Automatic Sounds.....	119
Electric Locomotive Controllable Sounds.....	119
Electric Locomotive Sounds.....	119
Electric Take Control Operation.....	20
Electric Traction Motor Sound-of-Power.....	15
Enabled Features.....	154
Engine Makes No Sounds.....	148
Engine Malfunction.....	148
Engine Slows During Horn.....	148
Entering Long (Extended) \Address in CV 56.129 ..	107
Entering short (Primary) Address in CV 56.129	106
Example Primary and Secondary Indices using CV 53.....	87

Program CV 17 and CV 18 to Extended Address (binary).....	40
Program CV 17 and CV 18 to Extended Address (decimal).....	40
Example: Reset Quantum to Original Factory Defaults	105
Example: Reset the Individual Sound Volumes to Factory Defaults.....	105
Example: Select Throttle Control.....	103
Example: Set Your Engine's ID to the Short Address "23".....	106
Example: Set Your Engine's Long Address to "5343"	107
Example: Set Your Engine's Long Address to "5344"	107
Example: For Dual Pump Steam Engines.....	94
Example: Hear the Current Setting for CV 2 V-Start.	111
Example: Hear the Current Setting for the Bell Volume.	111
Example: Play Version.....	109
Example: Set Long & Short Air Let-Off to an Output.	96
Examples of Common Train Numbers.....	107
Extended Address (see also CV 17,18) .	25, 39, 42, 53, 106, 107

F

F0 (see also FL).....	11
F0 or FL not affecting Headlight.....	13
F0-F12 Function Standard.....	11, 55
F0-F8 Function Standard.....	55
F0-F8 Function Standard.....	11
F1, Bell.....	13
F10.....	17
F10 Status Report.....	17
F213, 14, 15, 25, 43, 55, 63, 143, 165	
F2, Horn/Whistle.....	13
F313, 16, 26, 43, 55, 65, 66, 143, 165	
F3, Bell.....	13
F3, Coupler.....	14
F426, 43, 55, 67, 165	
F4, Steam Blower Hiss.....	14
F514	
F5, Dynamic Brakes.....	14
F615, 18, 19, 21	
F6 Start Up.....	18
F6, Doppler Operation.....	15
F716, 21	
F7 key in Neutral (Air Brakes).....	16
F7 Squealing Brakes & Flanges.....	16
F7, Air Brakes.....	16
F816	
F8, Mute.....	16
F917, 21, 45	
F9 Shut Down.....	18
F9, Cruise Control.....	17
Factory Default Settings.....	11, 28, 100
Factory Default Settings (Typical).....	22

Feature Assignments (also see CV 53).....	159	Squealing Brake and Flange Sounds	135
Feature ID (see QSI Feature Identifiers).....	86	Start Up	137
Feature Operation from Function Commands.....	153	Throttle Control.....	135
Feature Types.....	154	Turbine Mode to Diesel Mode	133
Firebox.....	14	Gas Turbine Prototype	123
Fireman.....	14	Air Compressor	123
FL12		Design and Description	123
FL (see also F0, F(f) and F(r)).....	12, 45	Diesel Alternator.....	123
FL or F0, Headlight & Reverse Light	12	Diesel-Generator	123
FL(f)	25, 52, 57, 160	Turbine Operation	124
FL(r)	25, 52, 160	Veranda Gas Turbines Specs	123
Flanges	11	Gas Turbine Prototype Operation	125
Flanges or Extended Brakes	116, 117, 119, 122	Dynamic Brakes	127
Forward (FWD).....	9, 15, 16, 17, 19, 43, 45, 96	Moving Under Turbine Power	127
Forward State	9, 86	Reversing the Locomotive.....	127
Forward Status Report (smph).....	17	Shutting Down the Locomotive	127
Forward Trim	26, 112	Starting the Diesel Motor.....	125
Forward Trim Factor	112	Stopping the Locomotive.....	127
Function Group 1	12, 52, 160	Turbine	127
Function Group 2.....	12, 160	Turbine Cranking.....	126
Function Groups	12, 159, 160	Gas Turbine Quantum Sounds.....	121
Function Inputs	55, 159	Automatic Sounds	121
Function Inputs and Outputs	160	Controllable Sounds.....	121
Function Key Feature Assignments.....	11	Gas Turbine Special Ops and Troubleshooting	142
Function Key Operation Explained.....	11	Manual Volume Adjustment	142
Function Keys	11, 12, 13, 14, 15, 16, 17, 18, 19, 20, 21, 43, 45, 55, 92, 96, 98, 100, 115, 117, 119, 122, 143, 148, 154, 159, 160	Reset Jumper	142

G

Gas Turbine DCC Programming	139
Doppler Shift.....	139
Individual Sound Volumes.....	139
Mute Volume	139
Reset	140
Setting ID's in Ops Mode.....	140
System Volume	139
Throttle Control.....	140
Verbal Announcements.....	141
Verbal Feedback	141
Gas Turbine Malfunction	148
Gas Turbine Operation under DCC	131
“Take Control” Operation.....	136
Automatic Features	136
Changing between Diesel and Gas Turbine Mode	132
Coupler and Coupler Crash Sou	134
Cruise Control	135
Diesel Mode to Turbine Mode	132
Directional Lighting Operation.....	134
Doppler Operation	135
Dynamic Brakes	136
Function Keys.....	131
Horn and Bell Buttons	135
Mute.....	137
Operation in Neutral	138
Shut Down	136
Sound of Power.....	134

Graph	
C5 Affect on Applied Motor Drive.....	33
CV 2 Affect on Applied Motor Drive	30
Speed Table Selections	49

H

Hardware Reset.....	150
Hardware Volume Controls	150
Headlight...9, 11, 12, 13, 52, 55, 56, 98, 100, 116, 148, 156, 157	
Headlight and Reverse Light Operation	11, 12
Headlight Malfunction	148
Headlight, non-dimmable.....	13
Helper	
End Helper	44, 46
End Helper Headlight	46
End Helper Reverse Light.....	46
Lead Locomotive	43, 45, 46
Mid Helper	44, 46
44, 46	
43, 45	
44, 46	
Horn.....	94, 119, 143, 160
Horn and Bell Buttons.....	13, 15

I

ID Numbers.....	143
Addressing Engines	7, 23
Extended Address (see also CV 17,18).....	39
Footnote	39
Forgotten	23

NMRA CV Specifications.....	85
Ops Mode Setting.....	24, 29, 41
Idle	14
Individual Sound Identifiers	95, 111
Individual Sound Volumes (see CV 52).....	94
Inertia (see also Momentum).....	10, 31, 32

L

Labored Sounds	11
Lashups (see also Consists)	42
46	
Level Activated	153
Level Activated Toggled Features.....	157
Level Activation Signaling.....	154
Lighting Malfunction.....	148
Locomotive Directional States	9
Locomotive Start Up (Extended)	122
Locomotive States	86
Long Address (see also Extended Address, CV 17,18)	
.....	39
Long Air Let-off.....	19, 95, 96, 97, 156
Long Form CV Access Instruction	42
18, 20	
Low Idle	18, 118, 122

M

Magnetic Wand.....	151
Manufacturer's ID	25
Manufacturer's Version Number.....	25
Mars Light.....	9
Mars Light (see also Hazard Light).....	13, 98, 156
Momentary Features.....	154
Momentum.....	31, 32
Motive State.....	11, 56, 86, 87, 160
Multiple Heading (see also Consist).....	42
Multiple Units (MU's) (see also Consist).....	42
Mute. 11, 16, 43, 44, 55, 68, 70, 72, 74, 76, 77, 79, 81,	
84, 86, 97, 100, 110, 111, 148, 154, 156, 157	
Mute Volume (see CV 51.1)	92

N

Neutral	9, 15, 16, 17, 19, 21, 43, 45
Neutral From Forward (NFF).....	9, 12, 96
Neutral From Reverse (NFR)	9, 12, 96
Neutral Sounds.....	21, 38
Neutral State.....	9, 11, 21, 56, 86, 160
Neutral Status Report	17
NMRA 7, 22, 23, 24, 25, 26, 27, 31, 32, 37, 38, 52, 53,	
85, 105, 111	
NMRA CV's Supported by Quantum	25
NMRA Standards.....	7
Null Output Feature.....	97
Number Board Lights.....	18, 98, 118, 156
Numeric Verbal Readout	88, 89

O

Operations Mode (Ops Mode) Programming.....	22, 23, 24, 29, 39, 91, 92, 105, 106, 108, 111
Operations Mode (Ops Mode) Troubleshooting.....	148
Outputs ...	13, 25, 26, 28, 43, 45, 55, 56, 57, 59, 61, 63, 65, 67, 69, 71, 73, 75, 77, 79, 81, 83, 86, 87, 100, 105, 155, 159, 160
Outputs and Features.....	160

P

Packet.....	52
Packet Time-out Value (see also CV11)	38
Polarity.....	52, 53, 163, 164
Pop-Off	18, 21, 95, 97, 115, 154, 156
Power Source Conversion (see also CV 29).	25, 38, 52
Primary Address	25, 29, 39, 42, 53, 106
Primary Index (PI).....	26, 28, 85, 86, 87, 88, 89, 90, 91, 92, 93, 94, 95, 96, 100, 101, 102, 103, 104, 105, 106, 108
Problems w/ Analog Operation.....	148
Programming	22
Programming a Long Address on Digitrax	145
Programming a Long Address on North Coast Engineering (NCE)	146
Programming Malfunction.....	149
Programming on the Main (see also Ops Mode Programming).....	24
Programming the Locomotive's Decoder	22
Programming Track	22, 23, 24, 110, 111, 143
Progressive Features	154
Proprietary Rights and Obligations.....	166

Q

QSI CV's	111
QSI Feature Identifiers	86, 97
QSI Quantum Sound	7
QSI Standard Speed Table	49
Quantum DCC Operation – Ref Manual Overview.....	8
Quantum Sound Decoder.....	23

R

Recommended Reading.....	162
Recommended value of CV 21 for an End Helper Engine in a Consist	46
Recommended value of CV 22 for a Lead engine in a Consist:	45
Recommended value of CV 22 for a Mid Helper engine in a Consist.....	46
Redirected Outputs.....	56
Regulated Throttle Control (RTC)	10, 102
Reset (see also CV 56.128)	
All CV's.....	105
All QSI CV's.....	105
All Standard NMRA CV's	105
Command Stations.....	143
CV 51, System Sound Control	105
CV 52, Individual Sounds.....	105

CV 53, Function Outputs	105
CV 56, QSI Configuration	105
Example	105
Jumper	24
Memory	22
Troubleshooting	149
Reset all CV's	105
Reset Hardware (Engine ID)	24
Reset Jumper	150
Reset Malfunction	149
Reset With Magnetic Wand	152
Returning to the Short Address on Digitrax	145, 146
Reverse (REV)	9, 15, 16, 17, 19, 43, 45, 96
Reverse Light. 11, 12, 13, 45, 46, 55, 56, 98, 100, 156, 160	
Reverse State	9, 86
Reverse Status Report (smph)	17
Reverse Trim	114
Reverse Trim Factor	114
Rights and Obligations	166
Rule 17	9

S

Scale Factor for smph	103, 104, 148
Scale Miles per Hour (smph) 10, 15, 16, 102, 103, 104, 148	
Scale Miles Per Hour Status Report	17
Secondary Index (SI)	26, 28, 85, 86, 87, 89, 90, 96, 100, 101, 102, 105
Service Mode ...7, 22, 23, 24, 29, 39, 41, 91, 106, 143, 149	
Service Mode Programming	22
Service Mode Troubleshooting	149
Short Address (see also Primary Address)	29
Short Air Let-off...15, 68, 70, 72, 74, 76, 77, 79, 81, 83, 87, 95, 97, 100, 156	
Short Form CV Access Instruction	42
Shut Down ... 11, 17, 18, 19, 21, 45, 55, 68, 70, 72, 74, 76, 78, 80, 82, 84, 98, 116, 117, 118, 120, 121, 122, 148, 154, 156, 157	
Smoke Generators	56
Smoke Stack	14
Software License Agreement	166
Sound Decoders	56
Sound of Power (Labored Sounds)	11, 14, 17, 18
Sound-of-Power, Diesel Motor	14
Sound-of-Power, Electric Traction Motor	15
Sound-of-Power, Steam Exhaust	14
Sounds Available Under DCC Operation	115
Special Sound Effects Enable	93
Speed Control (SC) .10, 30, 33, 53, 102, 103, 104, 148	
Speed Control Malfunction	148
Speed Curve Recommendations	34
Speed Curves	34, 49
Additional Information for the Curious	50
Fast Start (convex)	49
Linear	49
Slow Start (concave)	49

User Defined	49
Speed Step Mode (14,28,128)	52
Speed Steps ...9, 10, 17, 22, 31, 32, 47, 48, 50, 52, 85, 102, 104, 113, 148	
Speed Table	25, 113
Speed teqs	104
Squealing Brakes 16, 55, 68, 70, 72, 74, 76, 77, 79, 81, 83, 95, 97, 99, 100, 117, 119, 121, 148, 156	
Squealing Brakes and Flanges	16, 21
Standard NMRA CV's	111
Standard Throttle Control (STC)	9, 53, 102
Standby ...17, 18, 19, 68, 70, 72, 74, 76, 78, 80, 82, 84	
Start Up ...11, 18, 19, 21, 43, 44, 55, 56, 58, 60, 62, 64, 66, 68, 70, 72, 74, 76, 77, 79, 81, 83, 86, 98, 100, 116, 117, 120, 121, 157	
Start Up Diesel Engine	19
Start Up, Electric Loco	19
Start Up, Steam Engine	19
Start Voltage	30, 33
State Dependent Toggled Features	154
States (see also Locomotive States)	86
Status Report	17
Steam Automatic Sounds	115
Steam Chuff	115
Steam Controllable Sounds	115
Steam Engine Start Up	19
Steam Exhaust Sound-of-Power	14
Steam Hiss (see also Blowers and Fans)	14
Steam Locomotive	7
Steam Reverse Lever	18
Steam Sounds	115
Steam Take Control Operation	20
Strobe Ditch Lights	156
Super Heaters	18
System Volume (see CV 51.0)	91

T

Table	
Binary, Hexadecimal, Decimal Conversions	165
Column Index for CV 53 Index	90
CV 29 Common Settings	54
CV Numbers and Names	25
DCC Function Key	11
Decoder Output Numbers	55
Example of 2 Dimensional Index (PI & SI)	86, 89
Examples of Common Train Numbers	40, 107
Factory Default Settings	100
Individual Sound Identifiers	95, 111
Quantum Features	97
Recommended DCC Command Stations	143
Speed Curve	50
Summary of Light Operation	13
User Defined Light Speed Table Default Values	113
Table Indexing System, PI and SI	85
Take Control Features	155
Take Control Operation	19
Diesel	20
Electric	20

Steam	20
Throttle Control (see Standard Throttle Control)	9
Throttle Control Malfunction	148
Throttle Mode.....	101, 102
Toggled Features.....	154
Total Shut Down .17, 18, 19, 68, 70, 72, 74, 76, 78, 80, 82, 84	
Traction Motor Whine	119
Traction Motors.....	14, 95
Transition Activated	153
Transition from Diesel to Turbine and Ignition.....	121
Transition from Turbine to Diesel	122
Trim Factor	112, 114
Troubleshooting	
Operations Mode.....	148
Program Track Operation.....	149
Using the Quantum Reset Jumper:.....	150
Turbine Whine	121
Turbine Whoosh	121

V

V High	25
Verbal Acknowledgement.....	110
Verbal Readout (see CV 64)	26, 111
Verbal Reporting Malfunction	149
Verbal Speedometer Readout.....	17
V-Mid	25
Volume Adjustment Magnetic Wand	151
Volume Adjustment Potentiometer	151
Volume Control.....	17, 28, 85, 88, 91, 92, 94
Volume Control in db	94

W

Water Injector	21, 95, 97, 115, 156
Whistle	115
Whistle/Horn ...7, 11, 13, 14, 15, 57, 59, 61, 63, 65, 67, 69, 71, 73, 75, 95, 97	

© July 2006 QSIndustries, Inc. All rights reserved. Printed in the U.S.A. Information in this publication supersedes that in all previous published material. The contents and the product it describes are subject to change without notice. Broadway Limited is a trademark of Broadway Limited, Inc. Lionel is a registered trademark of Lionel LLC. QSI is a registered trademark of QSIndustries, Inc. Sound of Power, Quantum, QARC and Quantum Analog Remote Control are trademarks of QSIndustries, Inc. All other trademarks are the property of their respective holders. QSI makes no representations or warranties with respect to this publication. In no event shall QSIndustries, Inc., be liable for any damages, direct or incidental, arising out of or related to the use of this publication. Quantum DCC ref manual ver3R F(12)G(3)L(2)J(2) -fs